

HIGHER LEVEL



WORKED SOLUTIONS

PEARSON BACCALAUREATE

HIGHER LEVEL

Physics

2nd Edition

CHRIS HAMPER

Supporting every learner across the IB continuum

Worked solutions

Chapter 1

Exercises

- 1 (a) 48 000, move decimal point 4 places left
 4.8×10^4
- (b) 0.000036, move decimal point 5 places right
 3.6×10^{-5}
- (c) 14 500, move decimal point 4 places left
 1.45×10^4
- (d) 0.00000048, move decimal point 7 places right
 4.8×10^{-7}
- 2 (a) $5585 \text{ km} = 5.585 \times 10^6 \text{ m}$
- (b) $175 \text{ cm} = 1.75 \text{ m}$
- (c) $25.4 \mu\text{m} = 2.54 \times 10^{-5} \text{ m}$
- (d) 100,000 million, million, million km
 $= 10^5 \times 10^6 \times 10^6 \times 10^6 \text{ km} = 10^{22} \text{ km}$
 $= 10^{25} \text{ m}$
- 3 (a) 85 years
 $= 85 \times 365$ (days in a year)
 $\times 24$ (hours in a day) $\times 60$ (min in an hour)
 $\times 60$ (seconds in a min)
 $= 2.68 \times 10^9 \text{ s}$
- (b) $2.5 \text{ ms} = 2.5 \times 10^{-3} \text{ s}$
- (c) $4 \text{ days} = 4 \times 24 \times 60 \times 60 = 3.46 \times 10^5 \text{ s}$
- (d) 2 hours 52 min 59 s
 $= 2 \times 60 \times 60 + 52 \times 60 + 59$
 $= 7200 + 3120 + 59$
 $= 10379 = 1.04 \times 10^4 \text{ s}$
- 4 (a) $200 \text{ g} = 0.2 \text{ kg}$
- (b) $0.00001 \text{ g} = 1 \times 10^{-5} \text{ g} = 1 \times 10^{-8} \text{ kg}$
- (c) $2 \text{ tonne} = 2000 \text{ kg}$
- 5 Volume $= 5 \times 10 \times 3 = 150 \text{ m}^3$
- 6 (a) Hair is cylindrical

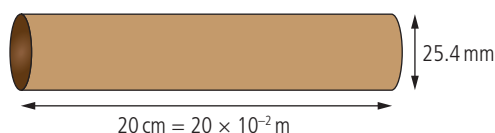

$$r = \frac{25.4}{2} = 12.7 \mu\text{m} = 12.7 \times 10^{-6} \text{ m}$$

$$\begin{aligned} \text{Volume} &= \pi r^2 \times l \\ &= \pi \times (12.7 \times 10^{-6})^2 \times 20 \times 10^{-2} \\ &= 1.0 \times 10^{-10} \text{ m}^3 \end{aligned}$$

(b) Radius of the Earth $= 6.378 \times 10^6 \text{ m}$
 (from text)
 Volume of sphere $= \frac{4}{3}\pi r^3$
 $= \frac{4}{3}\pi \times (6.378 \times 10^6)^3 = 1.09 \times 10^{21} \text{ m}^3$

7 $\rho = \frac{m}{V} \Rightarrow m = \rho V$
 Density of air, $\rho = 1.2 \text{ kg m}^{-3}$
 $V = 5 \times 10 \times 3 = 150 \text{ m}^3$
 $m = 1.2 \times 150 = 180 \text{ kg}$

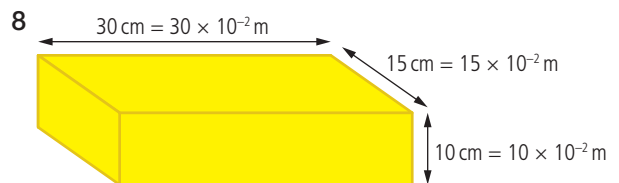

$$\begin{aligned} \text{Volume} &= 30 \times 15 \times 10 \times 10^{-6} \text{ m}^3 \\ &= 4500 \times 10^{-6} \text{ m}^3 \\ &= 4.5 \times 10^{-3} \text{ m}^3 \end{aligned}$$

$$\begin{aligned} \text{Density, } \rho &= \frac{m}{V} \Rightarrow m = \rho V \\ &= 1.93 \times 10^4 \times 4.5 \times 10^{-3} \\ &= 86.85 \text{ kg} \end{aligned}$$

- 9 From question 6, volume of Earth
 $= 1.09 \times 10^{21} \text{ m}^3$
 From text, mass of Earth $= 5.97 \times 10^{24} \text{ kg}$
 Density $= \frac{M}{V} = \frac{5.97 \times 10^{24}}{1.09 \times 10^{21}} = 5.48 \times 10^3 \text{ kg m}^{-3}$
- 10 The points on the first graph are not far spread from the line so the apples seem to be of almost equal size. On closer inspection the 4th point seems to be plotted in the wrong position since it is indicating the mass of $3\frac{1}{2}$ apples. The points on the second graph are more spread out so the apples appear to be slightly more uneven than the first case. On closer inspection the difference between 2 apples and 3 apples is very small. This is either due to an unusually small apple or a mistake.

The apples in the last graph are all of about the same size but according to the graph one apple has no size. This could be because of a systematic error in counting the apples (unlikely) or because the balance reading was always about 200g too low. It is also strange that the measurements start at two apples; why didn't the experimenter measure the mass of one apple first? Probably some mistake has been made transferring the data.

– Detective work!

11 Taking natural logs of A and B :

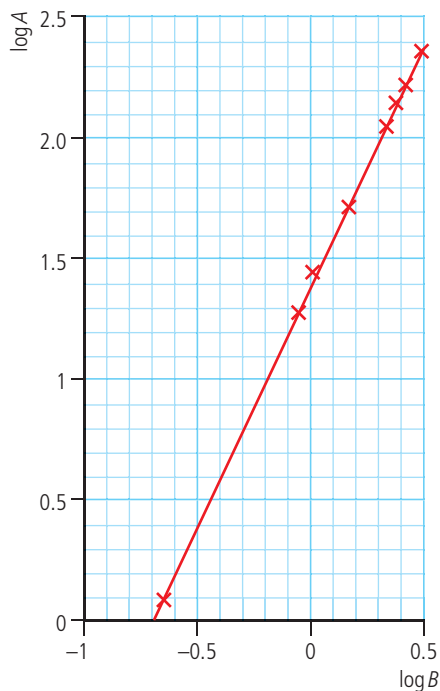

Equation of line $\log A = 2 \log B + 0.6$

$$A = 10^{0.6} B^2$$

$$A = 4B^2$$

12 $L = 0.050 \pm 0.001$ m

$$\% \text{ uncertainty} = \frac{0.001}{0.05} = 2\%$$

$$m = 1.132 \pm 0.002 \text{ kg}$$

$$\% \text{ uncertainty} = 0.18\%$$

$$\text{density} = \frac{m}{V} = \frac{1.132}{(0.05)^3} = 9056 \text{ kg m}^{-3}$$

$$\text{total \% uncertainty} = 0.18 + 3 \times 2 = 6.18\%$$

$$\frac{6.18}{100} \times 9056 = 560 \text{ kg m}^{-3}$$

$$\text{density} = 9056 \pm 560 \text{ kg m}^{-3}$$

13 $d = 400 \pm 1$ m

$$\text{total distance is } 4 \times 400 = 1600 \text{ m}$$

$$\text{total uncertainty is } 4 \times 1 = 4 \text{ m}$$

$$\text{distance is } 1600 \pm 4 \text{ m}$$

14 $T = 11.2 \pm 0.1$ s

$$\text{time for one swing is } \frac{11.2}{10} = 1.12 \text{ s}$$

$$\text{uncertainty for one swing is } \frac{0.1}{10} = 0.01 \text{ s}$$

$$\text{time for one swing} = 1.12 \pm 0.01 \text{ s}$$

15 (a)

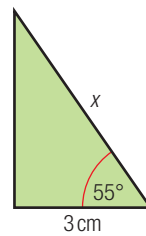

$$\cos \theta = \frac{3}{x}$$

$$x = \frac{3}{\cos 55} = 5.2 \text{ cm}$$

(b)

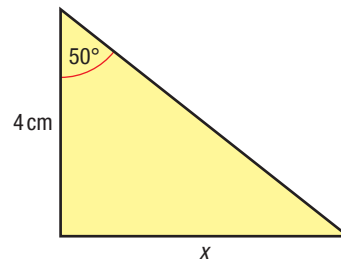

$$\tan 50^\circ = \frac{x}{4}$$

$$x = 4 \tan 50 = 4.8 \text{ cm}$$

(c)

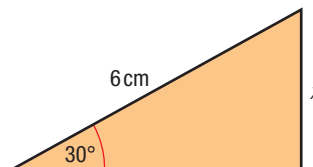

$$\sin \theta = \frac{x}{6}$$

$$x = 6 \sin 30 = 3 \text{ cm}$$

(d)

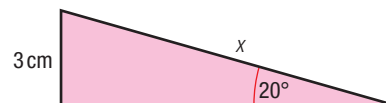

$$\sin \theta = \frac{3}{x}$$

$$x = \frac{3}{\sin 20} = 6 \text{ cm}$$

16 (a)

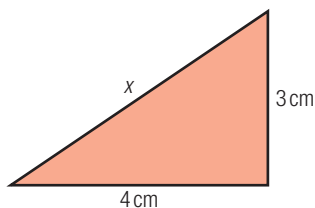

$$x = \sqrt{4^2 + 3^2} = \sqrt{25}$$

$$x = 5 \text{ cm}$$

(b)

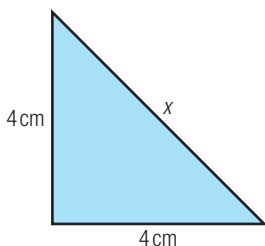

$$x = \sqrt{4^2 + 4^2} = \sqrt{32}$$

$$x = 5.66 \text{ cm}$$

(c)

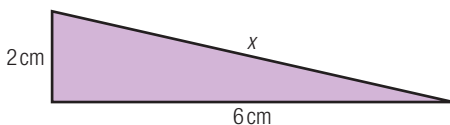

$$x = \sqrt{2^2 + 6^2} = \sqrt{40}$$

$$x = 6.32 \text{ cm}$$

(d)

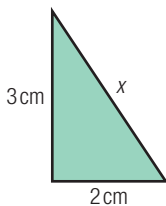

$$x = \sqrt{3^2 + 2^2} = \sqrt{13}$$

$$x = 3.61 \text{ cm}$$

17 By Pythagoras

$$R = \sqrt{4^2 + 8^2} = \sqrt{80}$$

$$R = 8.94 \text{ km}$$

$$\tan \theta = \frac{8}{4} \Rightarrow \theta = 63.4^\circ$$

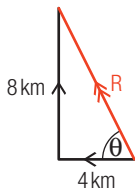

18 By Pythagoras

$$R = \sqrt{100^2 + 50^2} = 112 \text{ km}$$

$$\tan \theta = \frac{50}{100} \Rightarrow \theta = 26.6^\circ$$

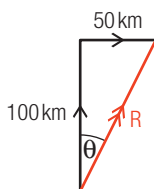

19 Component north = $10 \cos 30^\circ$
(because it's next to angle)
= 8.66 km

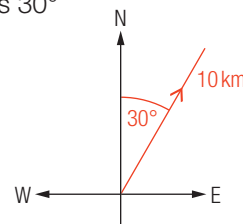

20 Component south = $8 \cos 20^\circ$
(because it's next to angle)
= 7.52 km

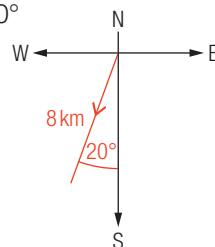

21 Vertical component = $500 \sin 60^\circ$
(not next to angle)
= 433 m

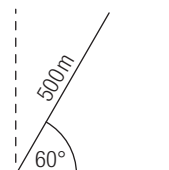

Practice questions

Note: You don't need to know about capacitors to answer this question.

1 (a) Use a convenient scale.

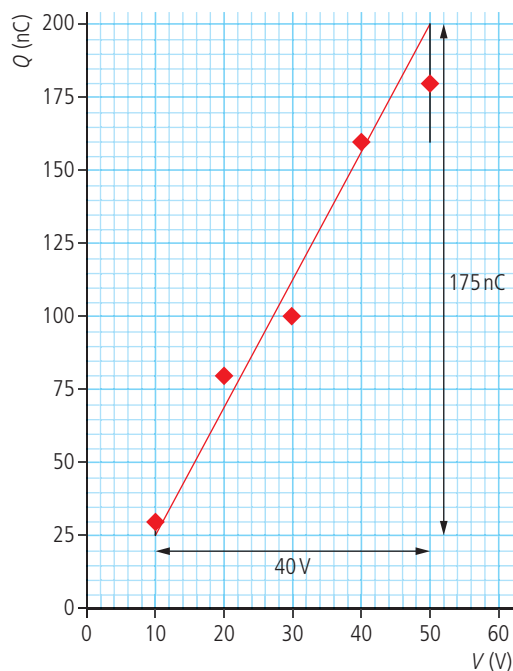

Note: The error bar on 30 nC is too small to plot accurately.

(b) Uncertainty in Q is 10% so error bar for 30 nC is ± 3 nC (about $\frac{1}{2}$ division) and for 180 nC ± 18 nC (about 4 divisions)

(c) Gradient of steepest line shown = $\frac{175}{40}$
 $= 4.4 \text{ nCV}^{-1}$

(d) Units of capacitance = CV^{-1}

(e) $Q = \frac{\epsilon_0 A}{d} V \Rightarrow \frac{Q}{V} = \frac{\epsilon_0 A}{d}$ where $\frac{Q}{V}$

is the gradient

$$\text{so } \frac{\text{gradient} \times d}{A} = \epsilon_0$$

$$\Rightarrow \frac{4.4 \times 10^{-9} \times 0.51 \times 10^{-3}}{0.15}$$

$$= 1.5 \times 10^{-11} \text{ CV}^{-1} \text{ m}^{-1}$$

2 If distance is between 49.8 cm and 50.2 cm then the mean value = $\frac{49.8 + 50.2}{2} = 50$ cm

The spread of the measurement

$$= 50.2 - 49.8 = 0.4 \text{ cm}$$

$$\text{So the uncertainty is } \pm \frac{0.4}{2} = 0.2 \text{ cm}$$

Measurement is 50 ± 0.2 cm

The answer is C.

$$3 \quad T = 2\pi \sqrt{\frac{m}{k}}$$

$$\text{Squaring, } T^2 = 4\pi^2 \frac{m}{k}$$

$$\Rightarrow T^2 \propto m$$

So T^2 plotted against m will be a straight line.

The answer is A.

$$4 \quad \text{Power} = I^2 R$$

uncertainty in $I = 2\%$

$$\text{so uncertainty in } I^2 = 2 \times 2\% = 4\%$$

uncertainty in $R = 10\%$

$$\text{so uncertainty in } I^2 R = 4 + 10 = 14\%$$

The answer is C.

5 A zero offset error means that when no current passes through the ammeter the reading is not zero.

If instead of zero the meter reads 0.1 A then all measurements will be 0.1 A too big.

The precision of each reading will not be altered but the readings will not be accurate. Like a football player hitting the post every time – precise but not accurate.

The answer is C.

$$6 \quad F = 10.0 \pm 0.2 \text{ N}$$

$$\% \text{ uncertainty} = \frac{0.2}{10} \times 100\% = 2\%$$

$$m = 2.0 \pm 0.1 \text{ kg}$$

$$\% \text{ uncertainty} = \frac{0.1}{2} \times 100\% = 5\%$$

$$\% \text{ uncertainty in } \frac{F}{m} = 2 + 5 = 7\%$$

When two numbers are divided their % uncertainties add.

The answer is C.

$$7 \quad \frac{\pi \times 8.1}{\sqrt{15.9}} = 6.38$$

To one significant figure, this is 6.

The answer is D.

8

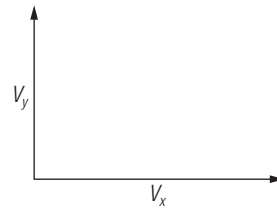

Velocity of x relative to y is found by subtracting the velocity of y from x.

This is the same as vector $x + (-\text{vector } y)$.

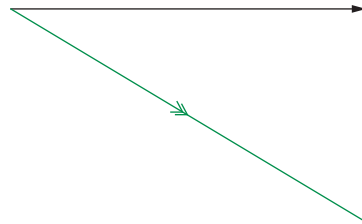

The answer is B.

9 The mass of an apple is about 100 g

$$\text{So its weight} = 0.1 \times 10 = 1 \text{ N}$$

This would be a small apple.

The answer is C.

10 (a) It isn't possible to draw a straight line that touches all error bars and passes through the origin.

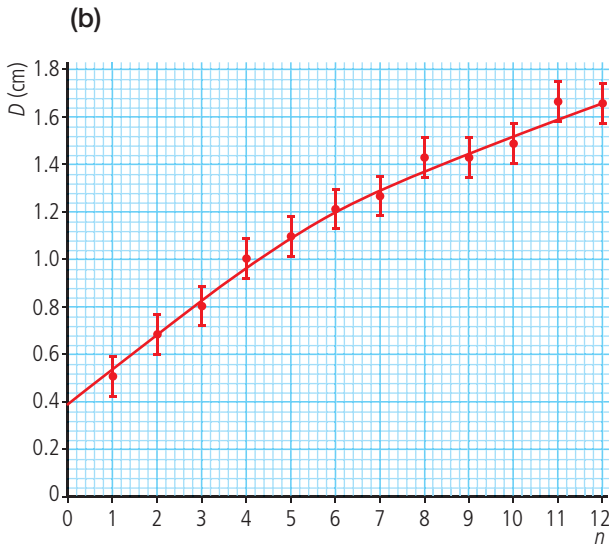

(c) $D = Cn^p$

$$\log_{10} D = \log_{10} C + p \log_{10} n$$

Plotting $\log_{10} D$ vs $\log_{10} n$ will give a straight line with gradient p ($y = mx + c$)

- (d) (i) From the error bars, the uncertainty in D for $n = 7$ is ± 0.08
 $\% \text{ uncertainty} = \left(\frac{0.08}{1.26} \right) \times 100\% = 6.3\%$
 uncertainty in $D^2 = 2 \times 6.3 = 13\%$

(ii) The straight line passes through all the error bars shown and the origin.

(iii)

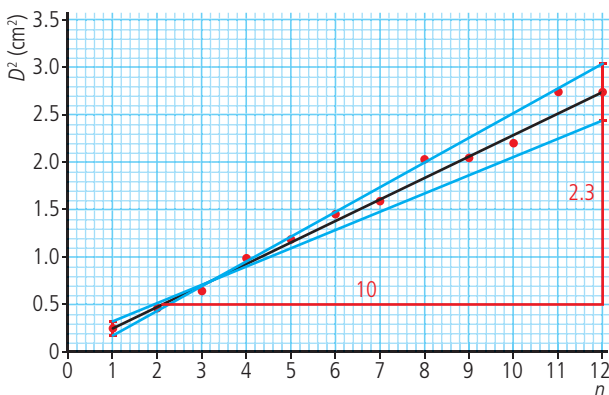

From graph, gradient of best fit line
 $= \frac{2.3}{10} = 0.23 \text{ cm}^2$

gradient of steepest line $= \frac{(3.1 - 0.2)}{11}$
 $= 0.26 \text{ cm}^2$

gradient of least steep line $= \frac{(2.4 - 0.3)}{11}$
 $= 0.19 \text{ cm}^2$

$$\text{Uncertainty} = \frac{(\text{max} - \text{min})}{2} = \frac{(0.26 - 0.19)}{2}$$

$$= 0.04 \text{ cm}^2$$

So gradient $= 0.23 \pm 0.04 \text{ cm}^2$

(iv) The unit of the constant is cm^2 .

Challenge yourself

1 $v = \frac{d}{t} = \frac{0.05}{0.06} = 0.83 \text{ ms}^{-1}$

Rearrange the equation: $g = \frac{7v^2}{10h}$

$$g = \frac{v^2 \times 7}{10 \times h} = \frac{0.83^2 \times 7}{10 \times 0.06} = 8.10 \text{ ms}^{-2}$$

Percentage uncertainty in $d = \left(\frac{0.5}{5} \right) \times 100 = 4\%$

Percentage uncertainty in $t = \left(\frac{0.01}{0.06} \right) \times 100 = 17\%$

Percentage uncertainty in $v = 4 + 17 = 21\%$

Percentage uncertainty in $h = \left(\frac{0.2}{6} \right) \times 100 = 3\%$

Percentage uncertainty in $g = \frac{v^2 \times 7}{10 \times h}$

$$= 2 \times 21 + 3 = 45\%$$

Absolute uncertainty $= \left(\frac{45}{100} \right) \times 8.10 = 3.62 \text{ ms}^{-2}$

Final value $= 8 \pm 4 \text{ ms}^{-2}$

The biggest uncertainty is in the measurement of time; this could be improved by repeating the measurement several times and taking the average.

Worked solutions

Chapter 2

Exercises

- 1 (a) $\frac{100 \text{ km}}{1 \text{ hour}} \rightarrow \frac{100000}{60 \times 60} = 27.8 \text{ m s}^{-1}$
 (b) $\frac{20 \text{ km}}{1 \text{ hour}} \rightarrow \frac{20000}{60 \times 60} = 5.6 \text{ m s}^{-1}$
- 2 (a) $\text{speed} = \frac{\text{distance}}{\text{time}} = \frac{400}{96} = 4.2 \text{ m s}^{-1}$
 (b) total displacement = 0 m
 average velocity = 0 m s^{-1}
 (c) After 48 s runner will be half way around, travelling south. The speed is constant, so the magnitude of the velocity will be 4.2 m s^{-1} .
 instantaneous velocity = 4.2 m s^{-1} (minus sign indicates travelling south)
 (d) After 24 s the runner will be $\frac{1}{4}$ way round

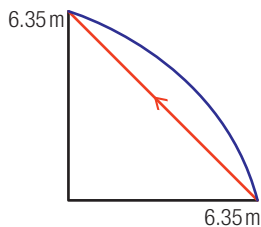

$$\text{displacement} = \sqrt{63.5^2 + 63.5^2} = 90 \text{ m}$$

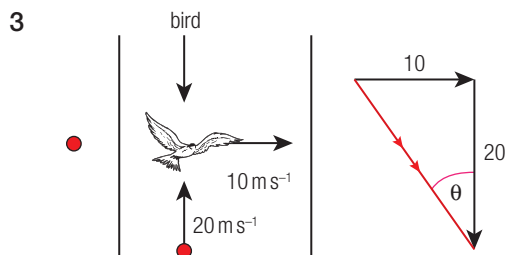

In this case we must subtract the velocity of the car

$$\text{velocity} = \sqrt{20^2 + 10^2} = 22.4 \text{ m s}^{-1}$$

$$\tan \theta = \frac{10}{20}$$

$$\theta = \tan^{-1} 0.5$$

$$\theta = 26.6^\circ$$

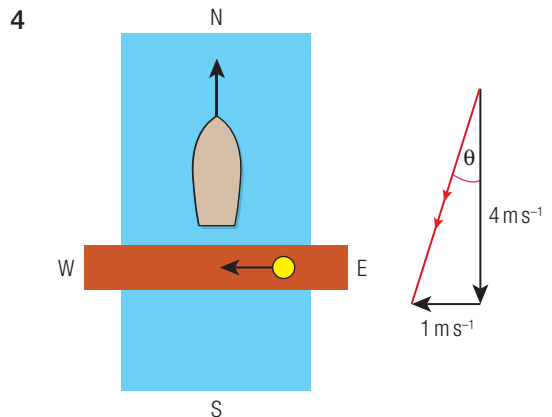

$$\text{relative velocity} = \sqrt{4^2 + 1} = 4.1 \text{ m s}^{-1}$$

$$\tan \theta = \frac{1}{4}$$

$$\theta = 14^\circ$$

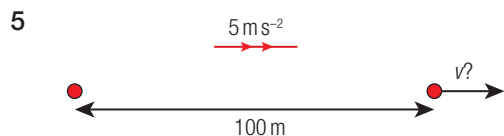

$$s = 100 \text{ m}$$

$$u = 0 \text{ m s}^{-1}$$

$$v = ?$$

$$a = 5 \text{ m s}^{-2}$$

$$t = -$$

$$\text{Use } v^2 = u^2 + 2as$$

$$v^2 = 2as = 2 \times 5 \times 100 = 1000$$

$$v = \sqrt{1000} = 31.6 \text{ m s}^{-1}$$

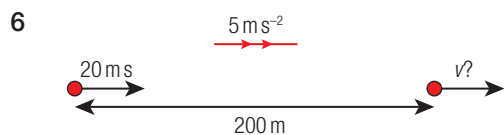

$$s = 200 \text{ m}$$

$$u = 20 \text{ m s}^{-1}$$

$$v = ?$$

$$a = 5 \text{ m s}^{-2}$$

$$t = -$$

$$\text{Use } v^2 = u^2 + 2as$$

$$v^2 = 20^2 + 2 \times 5 \times 200 = 2400$$

$$v = \sqrt{2400} = 49 \text{ m s}^{-1}$$

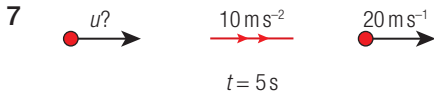

$s = -$
 $u = ?$
 $v = 20 \text{ ms}^{-1}$
 $a = 10 \text{ ms}^{-2}$
 $t = 5 \text{ s}$
 Use $a = \frac{v-u}{t} \Rightarrow u = v - at = 20 - 10 \times 5$
 $u = -30 \text{ ms}^{-1}$



$s = ?$
 $u = 30 \text{ ms}^{-1}$
 $v = -$
 $a = -10 \text{ ms}^{-2}$ (acceleration is negative)
 $t = 2 \text{ s}$
 Use $s = ut + \frac{1}{2}at^2 = 30 \times 2 - \frac{1}{2}10 \times 2^2$
 $= 60 - 20 = 40 \text{ m}$

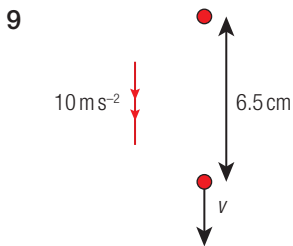

$s = 0.65 \text{ m}$
 $u = 0 \text{ ms}^{-1}$
 $v = ?$
 $a = -10 \text{ ms}^{-2}$
 $t = -$
 Use $v^2 = u^2 + 2as$
 $v^2 = 0 - 2 \times 10 \times 0.65 = 13$
 $v = \sqrt{13} = 3.6 \text{ ms}^{-1}$

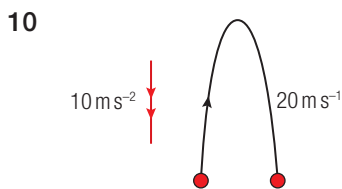

$s = 0 \text{ m}$
 $u = 20 \text{ ms}^{-1}$

$v = -20 \text{ ms}^{-1}$
 $a = -10 \text{ ms}^{-2}$
 $t = ?$
 Use $a = \frac{v-u}{t}$
 $t = \frac{v-u}{a}$
 $= \frac{-20 - 20}{-10} = 4 \text{ s}$

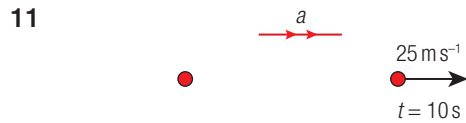

distance travelled = area = $\frac{1}{2} \times 10 \times 25 = 125 \text{ m}$
 acceleration = gradient = $\frac{25}{10} = 2.5 \text{ ms}^{-2}$

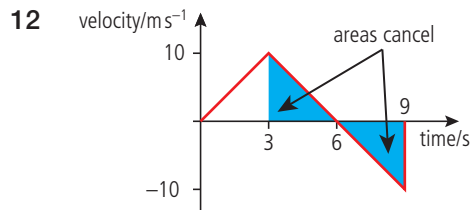

positive acceleration of $\frac{10}{3} \text{ ms}^{-2}$ for 3 s
 followed by negative acceleration of $\frac{10}{3} \text{ ms}^{-2}$
 for 6 s
 displacement = area under graph = $\frac{10 \times 3}{2}$
 $= 15 \text{ m}$

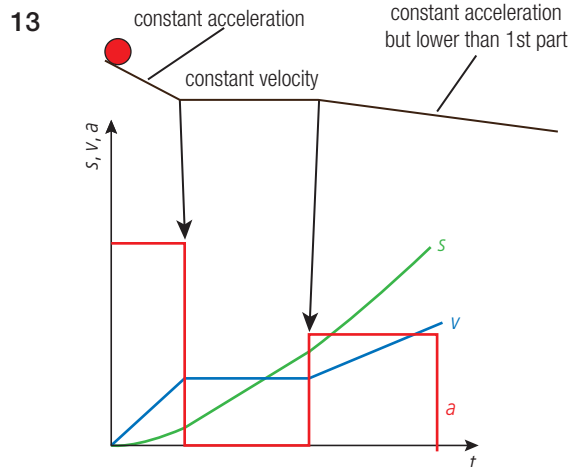

14

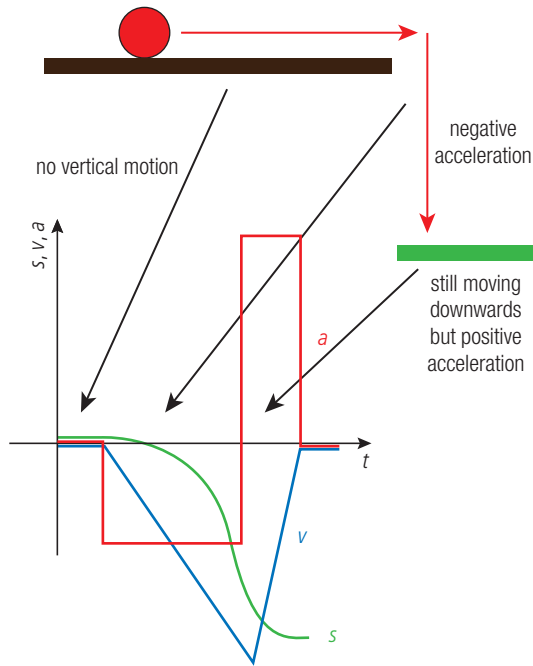

15

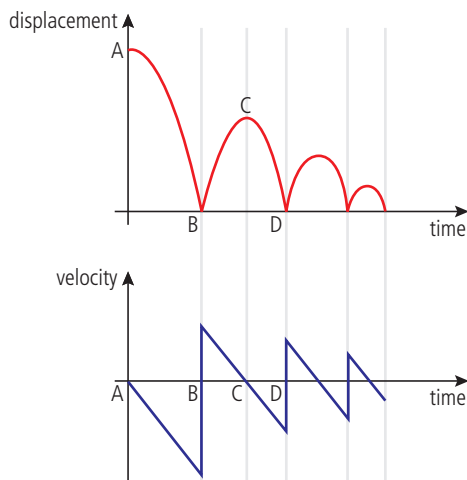

A The gradient starts from zero and becomes more negative as the ball falls.

B The ball bounces and the velocity suddenly changes to a positive value with slightly less magnitude.

As the ball rises it slows down until it stops at **C**.

The velocity then becomes negative as it falls. Note the gradient of all the diagonal parts is the same; this is because g is constant.

The velocity just after the ball leaves the ground is the same as the velocity just before it hits the ground.

16

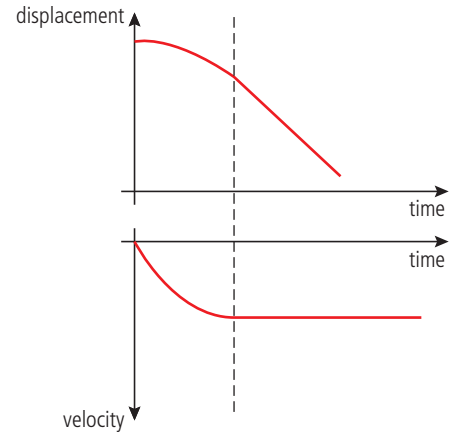

The gradient of the displacement–time graph starts from zero and gets more negative until it reaches a constant value.

17

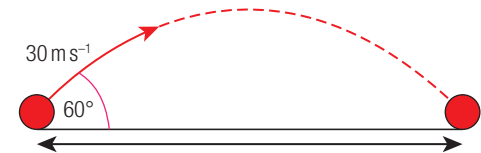

From vertical components

$$s = 0$$

$$u = 30 \times \sin 60^\circ = 26 \text{ ms}^{-1}$$

$$v = -26 \text{ ms}^{-1}$$

$$a = -10 \text{ ms}^{-2}$$

$$t = ?$$

$$\text{Using } a = \frac{v-u}{t}, \quad t = \frac{v-u}{a}$$

$$= \frac{-26 - 26}{-10} = 5.2 \text{ s}$$

From horizontal components

$$s = vt = 30 \times \cos 60^\circ \times 5.2 = 78 \text{ m}$$

18

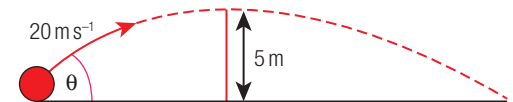

Vertical motion

$$s = 5 \text{ m}$$

$$u = 20 \times \sin \theta$$

$$v = 0$$

$$a = -10 \text{ ms}^{-2}$$

$$t = -$$

$$\text{(a) } v^2 = u^2 + 2as$$

$$0 = u^2 - 2 \times 10 \times 5$$

$$\Rightarrow u = \sqrt{100} = 10 \text{ ms}^{-1}$$

$$\therefore 20 \times \sin \theta = 10, \quad \sin \theta = \frac{1}{2}, \quad \theta = 30^\circ$$

(b) $a = \frac{v-u}{t} \Rightarrow$ time to reach wall $t = \frac{v-u}{a}$

$t = \frac{0-10}{-10} = 1\text{ s}$

In this time, horizontal displacement = $v_h t$
 $= 20 \times \cos 30^\circ \times 1 = 17.3\text{ m}$

19

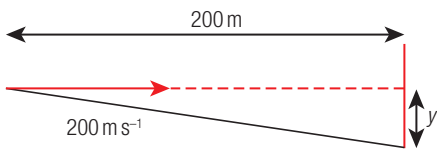

Using horizontal components

$v = \frac{d}{t} \Rightarrow t = \frac{d}{v} = \frac{200}{200} = 1\text{ s}$

Using vertical components

$s = y$

$u = 0$

$v = -$

Convenient to take down as positive in this example.

$a = 10\text{ ms}^{-2}$

$t = 1\text{ s}$

$s = ut + \frac{1}{2}at^2 \Rightarrow y = 0 \times 1 + \frac{1}{2} \times 10 \times 1^2$

$y = 5\text{ m}$

20



maximum distance is when $\theta = 45^\circ$

Using vertical components

$s = 0$

$u = 20 \times \sin 45^\circ = 14.14\text{ ms}^{-1}$

$v = -20 \times \sin 45^\circ = -14.14\text{ ms}^{-1}$

$a = -10\text{ ms}^{-2}$

$t = ?$

$a = \frac{v-u}{t} \Rightarrow t = \frac{v-u}{a}$

$= \frac{-14.14 - 14.14}{-10} = 2.8\text{ s}$

Using horizontal components

Range = $v \times t = 14.14 \times 2.8 = 39.6\text{ m}$

21

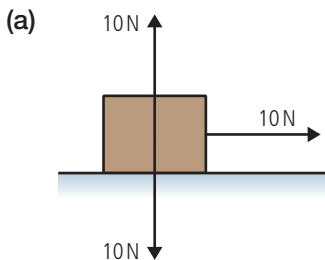

4

Vertical components cancel, so resultant = 10N to the right

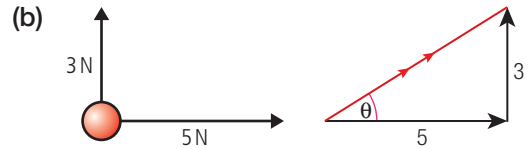

Resultant = $\sqrt{5^2 + 3^2} = 5.8\text{ N}$

Angle $\theta = \tan^{-1} \frac{3}{5} = 31^\circ$

22 (a)

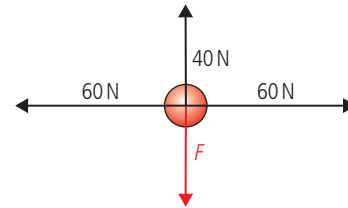

Horizontal forces cancel

$F = 40\text{ N}$

(b)

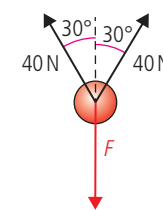

Horizontal forces cancel

Vertical components of upward force

$= 2 \times 40 \times \cos 30^\circ = 69\text{ N}$

23 (a)

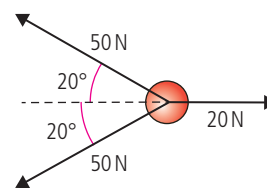

Vertical components cancel:

$50 \times \sin 20^\circ - 50 \times \sin 20^\circ = 0$

Horizontal components:

$20 - 2 \times 50 \times \cos 20^\circ = -74\text{ N}$

(b)

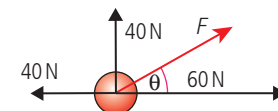

Horizontal components: $60 - 40 = 20\text{ N}$

Resultant = $\sqrt{40^2 + 20^2} = 45\text{ N}$

Angle $\theta = \tan^{-1} \frac{40}{20} = 63.4^\circ$

24 (a)

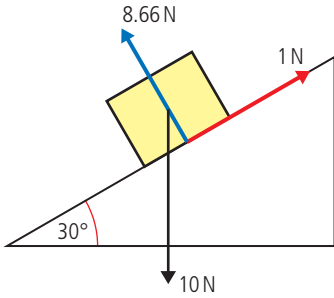

Parallel to slope:
 Resultant = $10 \times \sin 30^\circ - 1$
 $= 5 - 1 = 4\text{N}$ down slope.
 Perpendicular to slope:
 Resultant = $8.66 - 10 \times \cos 30^\circ = 0$
 Resultant force = 4N down the slope.

(b)

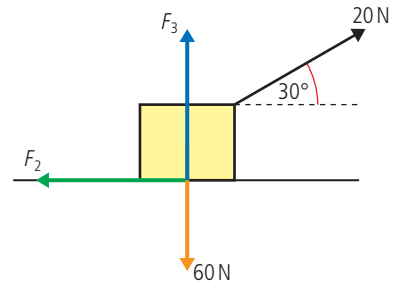

Horizontally
 $F_2 = 20 \times \cos 30^\circ$
 $F_2 = 17.3\text{N}$
 Vertically
 $F_3 + 20 \times \sin 30^\circ = 60$
 $F_3 = 60 - 10 = 50\text{N}$

(b)

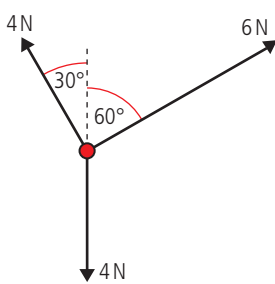

Vertical $R = 4 \times \cos 30^\circ + 6 \times \cos 60^\circ - 4$
 $= 3.46 + 3 - 4 = 2.46\text{N}$ (up)
 Horizontal $R = 6 \times \sin 60 - 4 \times \sin 30^\circ$
 $= 5.20 - 2 = 3.2\text{N}$ (right)

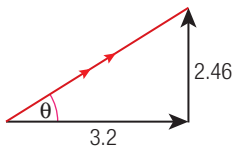

Resultant = $\sqrt{3.2^2 + 2.46^2} = 4\text{N}$
 Angle $\theta = \tan^{-1} \frac{2.46}{3.2} = 37.6^\circ$

25 (a)

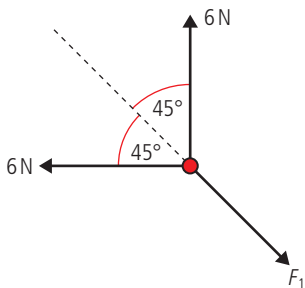

Taking components along the line of F_1
 $2 \times 6 \times \cos 45^\circ = F_1$
 $F_1 = 8.49\text{N}$

26

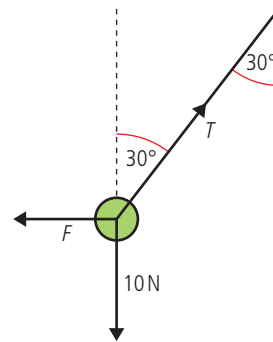

- (a) Since forces are balanced
 horizontal resultant = 0
 $\Rightarrow F = T \sin 30^\circ$
 (b) Vertical resultant = 0
 $\Rightarrow 10 = T \cos 30^\circ$
 (c) $T = \frac{10}{\cos 30^\circ} = 11.5\text{N}$
 (d) $F = 11.5 \times \sin 30^\circ = 5.8\text{N}$

27

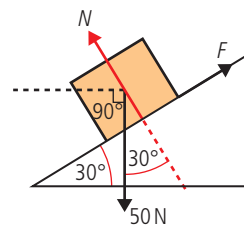

- (a) Parallel to ramp
 $F = 50 \times \sin 30^\circ$
 (b) Perpendicular to ramp
 $N = 50 \times \cos 30^\circ$
 (c) $F = 25\text{N}$
 $N = 43.3\text{N}$

28

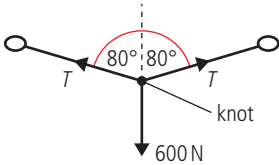

- (a) Vertical components
 $2T \times \cos 80^\circ = 600 \text{ N}$
- (b) Horizontal components
 $T \times \sin 80^\circ = T \times \sin 80^\circ$
- (c) $T = \frac{600}{2 \times \cos 80^\circ} = 1728 \text{ N}$

29

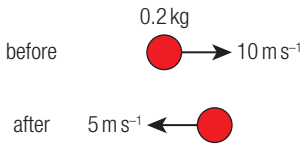

momentum before = $0.2 \times 10 = 2 \text{ N s}$
 momentum after = $0.2 \times -5 = -1 \text{ N s}$
 impulse = change in momentum
 = final - initial
 = $-1 - 2 = -3 \text{ N s}$

30

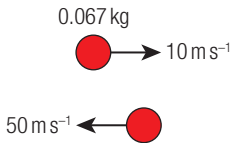

momentum before = $0.067 \times 10 = 0.67 \text{ N s}$
 momentum after = $0.067 \times -50 = -3.35 \text{ N s}$
 impulse = change in momentum
 = $-3.35 - 0.67$
 = -4.02 N s

31

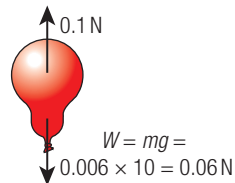

Upward force = $0.1 - 0.06$
 = 0.04 N
 $F = ma \Rightarrow a = \frac{F}{m}$
 = $\frac{0.04}{0.006} = 6.7 \text{ ms}^{-2}$

32 Acceleration = $\frac{v - u}{t} = \frac{0.1 - 0}{2} = 0.05 \text{ ms}^{-2}$



Resultant $F = ma = 50 \times 0.05 = 2.5 \text{ N}$

Resultant $F: 1000 - F = 2.5 \Rightarrow F = 997.5 \text{ N}$
 Friction = 997.5 N

33

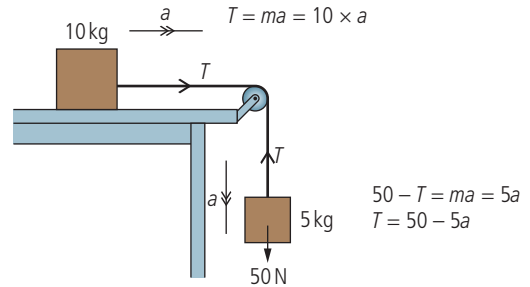

- (a) Equating the equations for T :
 $10a = 50 - 5a$
 $15a = 50$
 $a = 3.3 \text{ ms}^{-2}$
- (b) Using the equation at the top of the diagram
 $T = 10a = 10 \times 3.3 = 33 \text{ N}$

34

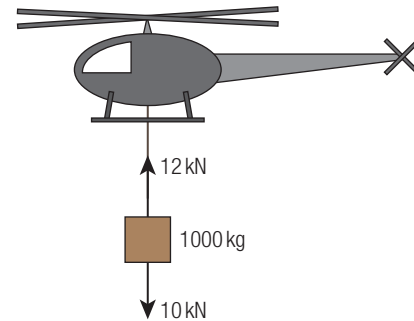

Resultant force = 2 kN
 $\Rightarrow a = \frac{F}{m} = \frac{2000}{1000} = 2 \text{ ms}^{-2}$

35

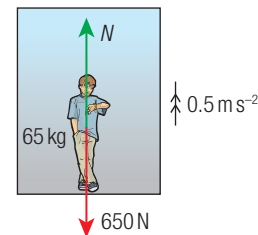

$F = ma = 65 \times 0.5 = 32.5 \text{ N}$
 Resultant force = 32.5 N
 $\Rightarrow N - 650 = 32.5$
 $N = 682.5 \text{ N}$

36

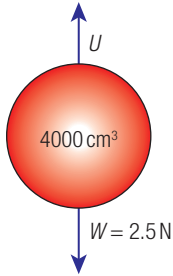

- (a) U = weight of fluid displaced
 volume displaced = $4000 \times 10^{-6} \text{ m}^3$
 mass displaced = $\rho U = 1000 \times 0.004$
 = 4 kg

Upthrust = 40 N

Resultant $F = 40 - 2.5 = 37.5 \text{ N}$ up.

- (b) $a = \frac{F}{m} = \frac{37.5}{0.25} = 150 \text{ ms}^{-2}$

Friction will act against the motion of the ball

37

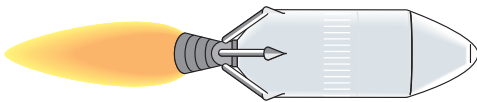

- (a) Newton 1: Since the velocity of the gas changes there must be an unbalanced force on the gas.
 Newton 3: If the rocket exerts a force on the gas the gas must exert a force on the rocket. This force is unbalanced so the rocket accelerates.
- (b) Same as 37(a) but replace gas with water and rocket with boat.
- (c) Skateboard replaces rocket, person replaces gas.
- (d) The ball accelerates up due to upthrust. If the water pushes ball up then ball pushes water down so the reading on balance will increase.

38

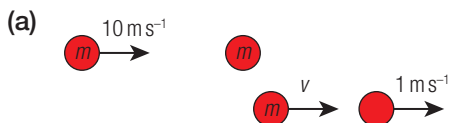

Before collision momentum = $m \times 10 + m \times 0$
 After collision momentum = $mv + m \times 1$
 Conservation of momentum $\Rightarrow 10m = mv + m$
 $\Rightarrow 9m = mv$
 $v = 9 \text{ ms}^{-1}$

(b)

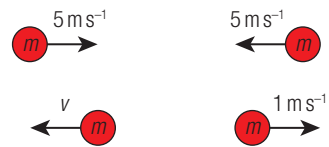

Before collision momentum = $-5m + 5m = 0$
 After collision momentum = $-mv + m$
 Conservation of momentum $\Rightarrow 0 = -mv + m$
 $m = mv$
 $v = 1 \text{ ms}^{-1}$ (Could be + or - depending on which ball you take.)

(c)

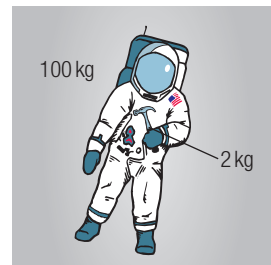

Must throw the hammer away from the ship.

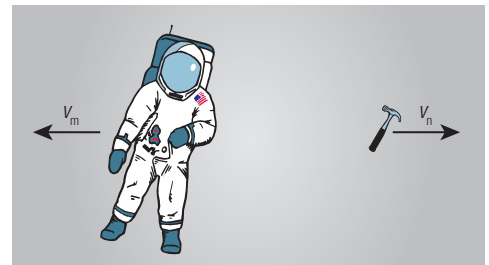

Must travel 2 m in 2 min

$$\Rightarrow v_m = \frac{2}{120} = 0.017 \text{ ms}^{-1}$$

momentum before = momentum after

$$0 = -100 \times 0.017 + 2 \times v_h$$

$$v_h = \frac{1.7}{2} = 0.85 \text{ ms}^{-1} \text{ Sounds possible.}$$

39

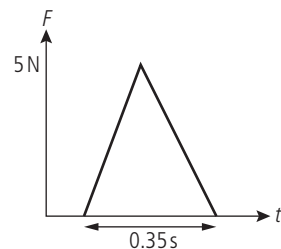

- (a) Impulse = area
 $= \frac{1}{2} \times 5 \times 0.35$
 $= 0.875 \text{ Ns}$

(b) Impulse = change of momentum = $m\Delta v$
 $m\Delta v = 0.875 \text{ Ns}$
 so if $m = 0.02 \text{ kg}$
 $0.02 \times \Delta v = 0.875$
 $\Delta v = \frac{0.875}{0.02} = 44 \text{ ms}^{-1}$

40 Impulse = area = $0.5 \times 0.35 \times 5 = 0.875 \text{ Ns}$
 Change in velocity = $\frac{\Delta mv}{m} = \frac{0.875}{0.02} = 43.75 \text{ ms}^{-1}$
 = final velocity since initial was zero

From conservation of energy $\frac{1}{2}mv^2 = mgh$
 so $h = \frac{v^2}{2g} = \frac{43.75^2}{2 \times 9.8} = 7.7 \text{ m}$

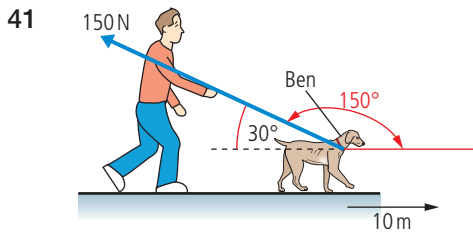

Use 150° since this is the angle between direction of F and displacement.

(a) Work done = $150 \cos 150^\circ \times 10 \text{ m}$
 $= -1300 \text{ J}$

(b) Dog is doing the work.

42 Since displacement = 0, no work is done.

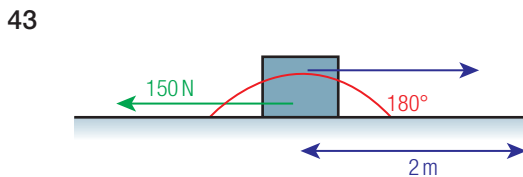

Work done = $150 \cos 180^\circ \times 2$
 $= -300 \text{ J}$

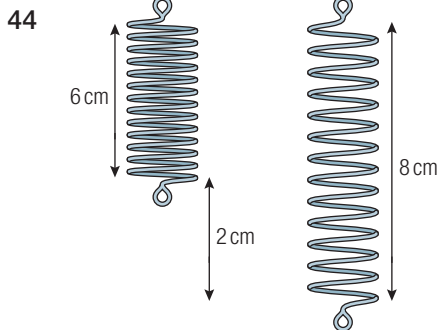

(a) Spring is stretched 2 cm.

(b) $F = kx$
 $F = 2 \times 2 = 4 \text{ N}$

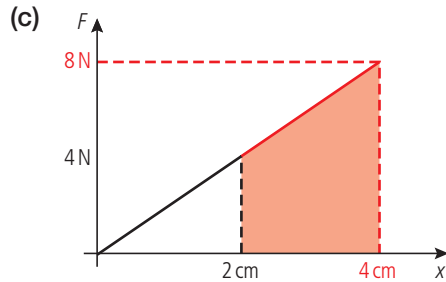

(d) Work done = area under graph = $\frac{1}{2} \times 4 \times 2$
 $= 4 \text{ J}$

(e) Red area = $2 \times \frac{1}{2} (4 + 8) = 12 \text{ J}$

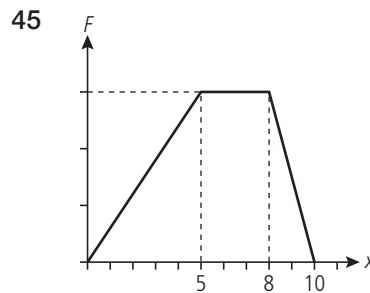

Area = $\frac{1}{2} \times 300 \times 5 + 300 \times 3 + \frac{1}{2} \times 300 \times 2$
 $= 750 + 900 + 300$
 $= 1950 \text{ J}$

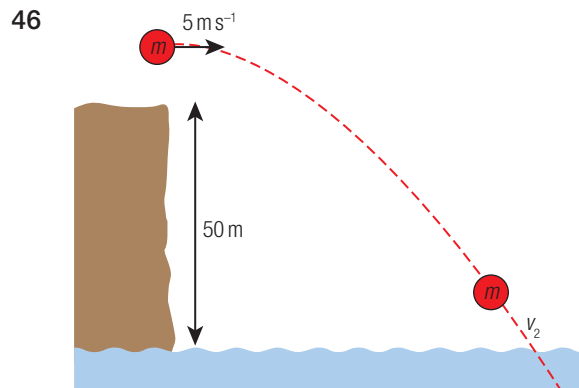

At top of cliff the stone has

$PE + KE = \frac{1}{2} mv_1^2 + mgh$

At the bottom the stone has only $KE = \frac{1}{2} mv_2^2$

Conservation of energy

$\Rightarrow \frac{1}{2} m \times 5^2 + m \times 10 \times 50$

$= \frac{1}{2} mv_2^2$

$v_2^2 = 2 \times \left(\frac{1}{2} \times 5^2 + 10 \times 50 \right) = 1025$

$v_2 = 32 \text{ ms}^{-1}$

47

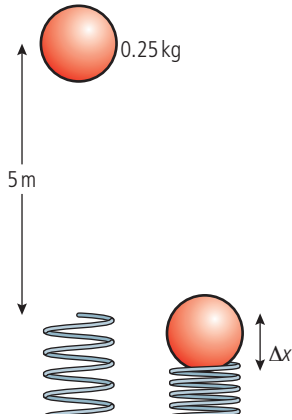

(a) When ball hits spring

$$\begin{aligned} \text{KE} &= \text{original PE} \\ &= mgh \\ &= 0.25 \times 10 \times 5 \\ &= 12.5 \text{ J} \end{aligned}$$

(b) Ball loses all its energy so work done = loss of energy.

$$\text{Work done} = 12.5 \text{ J}$$

(c) Energy given to spring = $\frac{1}{2}kx^2$

$$\begin{aligned} 12.5 &= \frac{1}{2} \times 250\,000 \times x^2 \\ x^2 &= 0.0001 \\ x &= 0.01 \text{ m} = 1 \text{ cm} \end{aligned}$$

(Note: We have ignored the loss of PE by the ball as it squashes the spring; this is very small.)

48

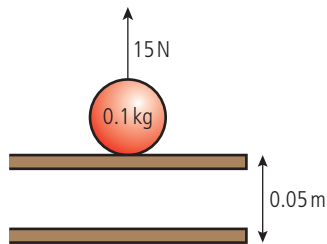

(a) Work done = $F \times d$

$$\begin{aligned} &= 15 \times 0.05 \\ &= 0.75 \text{ J} \end{aligned}$$

(b) Work done will increase the PE of the ball

$$\begin{aligned} \text{Increase in PE} &= 0.75 \text{ J} = mgh \\ 0.75 &= 0.1 \times 10 \times h \\ h &= 0.75 \text{ m} \end{aligned}$$

49

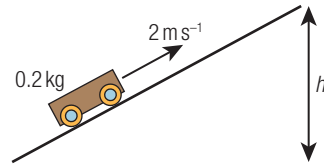

(a) Original KE = final PE

$$\frac{1}{2}mv^2 = mgh$$

$$h = \frac{v^2}{2g} = \frac{2^2}{2 \times 10} = 0.2 \text{ m}$$

(b) If $v = 4 \text{ ms}^{-1}$, $h = \frac{4^2}{2 \times 10} = 0.8 \text{ m}$

50 (a) Work done = $mgh = 2 \times 9.8 \times 100 = 1.96 \text{ kJ}$

(b) Efficiency = (useful work/work in) $\times 100\%$

$$45 = \frac{1.96 \times 10^3 \times 100}{E}$$

$$E = 4.36 \text{ kJ}$$

51 (a) Useful work = gain in KE

$$\begin{aligned} \text{Convert velocity to } \text{ms}^{-1} &= 100 \times \frac{1000}{(60 \times 60)} \\ &= 27.7 \text{ ms}^{-1} \end{aligned}$$

$$\begin{aligned} \text{KE} &= \frac{1}{2}mv^2 = \frac{1}{2} \times 100 \times 27.7^2 \\ &= 3.86 \times 10^5 \text{ J} \end{aligned}$$

(b) $60 = 3.86 \times 10^5 \times \frac{100}{E}$

$$E = 6.43 \times 10^5 \text{ J} = 0.643 \text{ MJ}$$

(c) 36 MJ per litre so $\frac{0.643}{36} = 1.8 \times 10^{-2} \text{ l}$

52

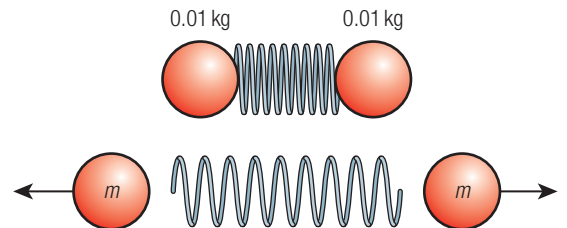

(a) Work done to compress spring = elastic PE of spring = $\frac{1}{2}kx^2$

$$\begin{aligned} &= \frac{1}{2} \times 0.1 \times 0.05^2 \\ &= 1.25 \times 10^{-4} \text{ J} \end{aligned}$$

(b) KE gained by balls = $1.25 \times 10^{-4} \text{ J}$

$$\begin{aligned} \text{Since balls are the same must get} \\ \frac{1}{2} \times 1.25 \times 10^{-4} \text{ J each} \\ &= 6.25 \times 10^{-5} \text{ J} \end{aligned}$$

(c) $\text{KE} = \frac{1}{2}mv^2 = 6.25 \times 10^{-5} \text{ J}$

$$v^2 = \frac{2 \times 6.25 \times 10^{-5}}{0.01}$$

$$v = 0.1 \text{ ms}^{-1}$$

53

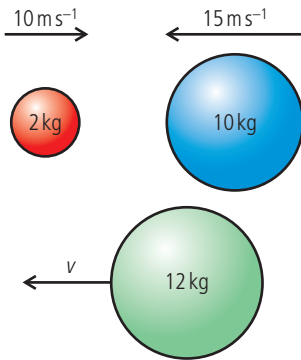

- (a) Momentum before = $2 \times 10 - 10 \times 15$
 $= 20 - 150 = -130 \text{ N s}$
 Momentum after = $12 \times v$
 Conservation of momentum: $-130 = 12v$
 $v = -10.83 \text{ ms}^{-1}$
- (b) KE before = $\frac{1}{2} \times 2 \times 10^2 + \frac{1}{2} \times 10 \times 15^2$
 $= 100 + 1125 = 1225 \text{ J}$
 KE after = $\frac{1}{2} \times 12 \times 10.83^2 = 703.7 \text{ J}$
 Energy loss = 521.3 J

54

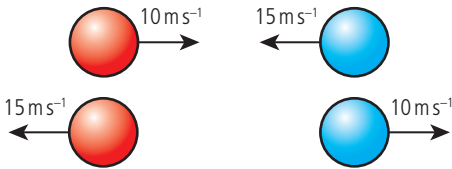

If collision is elastic the velocities swap.

55

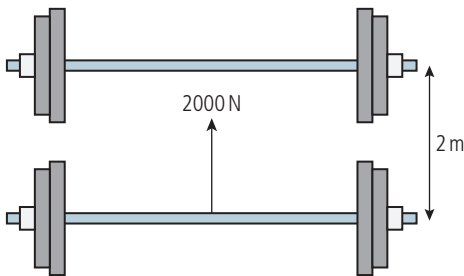

- Work done lifting weight = $2000 \times 2 = 4000 \text{ J}$
 $\text{power} = \frac{\text{work done}}{\text{time}} = \frac{4000}{5} = 800 \text{ W}$

56

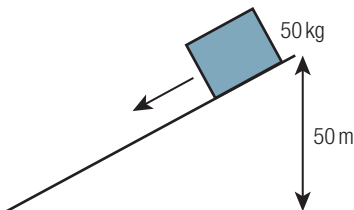

- PE loss = $mgh = 50 \times 10 \times 50 = 25000 \text{ J}$
 $\text{power} = \frac{\text{energy}}{\text{time}} = \frac{25000}{25} = 1000 \text{ W}$

57

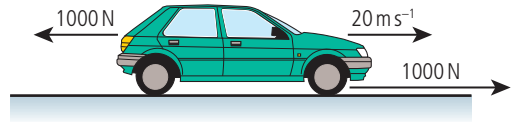

- If velocity constant, forces are balanced so
 forward force = 1000 N
 In 1 s the car moves 20 m so work done
 $= 1000 \times 20 = 20000 \text{ J}$
 Power = work done per second = 20 kW

58

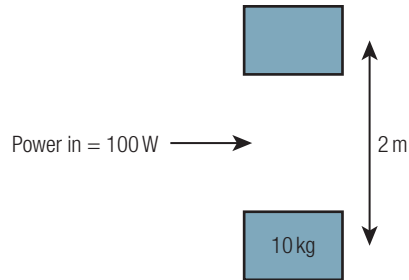

- Useful work = $mgh = 10 \times 10 \times 2 = 200 \text{ J}$
 $\text{power} = \frac{\text{work}}{\text{time}} = \frac{200}{4} = 50 \text{ W}$
 $\text{efficiency} = \frac{\text{power out}}{\text{power in}} \times 100\% = \frac{50}{100} \times 100\%$
 $= 50\%$

59

- $\text{efficiency} = \frac{\text{energy out}}{\text{energy in}} = \frac{E}{60} = \frac{70}{100}$
 $E = 60 \times \frac{70}{100} = 42 \text{ kJ}$

60

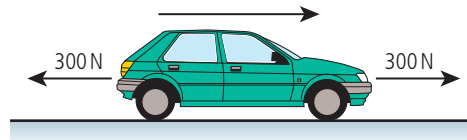

- (a) Constant velocity \Rightarrow forces balanced
 \Rightarrow forward force = 300 N
 $\text{power} = \text{force} \times \text{velocity} = 300 \times \frac{80000}{3600}$
 $= 6.67 \text{ kW}$
- (b) $\text{efficiency} = \frac{\text{power out}}{\text{power in}} = \frac{6.67}{11.1} = \frac{60}{100}$
 $\text{power in} = 11.1 \text{ kW}$

Practice questions

1

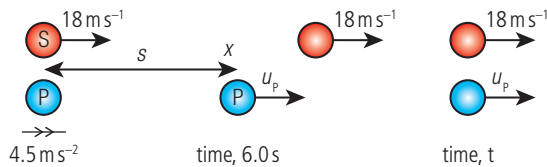

- (a) (i) Car S travels at constant velocity so
 $s_s = 18 \times t$
- (ii) Police car has constant acceleration so
 $s = ut + \frac{1}{2} at^2$
 $s_p = 0 \times 6.0 + \frac{1}{2} \times 4.5 \times 6.0^2$
 $= 81 \text{ m}$
- (iii) Using $a = \frac{v-u}{t} \Rightarrow v = at + u$
 $= 4.5 \times 6.0 + 0 = 27 \text{ m s}^{-1}$
- Could use $v^2 = u^2 + 2as \Rightarrow$
 $v = \sqrt{2 \times 4.5 \times 81} = 27 \text{ m s}^{-1}$ but not
 good practice to use s since if you
 calculated it wrong in part (ii) then this
 would be wrong.
 However, since errors are not carried
 forward you would not lose marks if you
 did this.
- (iv) Police car travels at constant velocity
 from 6.0 s until the cars meet at time t .
 So time at constant velocity $= (t - 6.0)$
 $\Rightarrow x = 27(t - 6.0)$

- (b) The police car catches up (draws level) with
 car S when they have travelled the same
 distance.
 Distance travelled by S in time $t = 18t$
 Distance travelled by P $= 81 + 27(t - 6.0)$
 So when they meet $18t = 81 + 27(t - 6.0)$
 $18t = 81 + 27t - 162$
 $18t - 27t = 81 - 162$
 $t = 9.0 \text{ s}$

- 2 (a) Mass can be defined in two ways:
- In terms of the force experienced by a
 mass in a gravitational field
 $F = mg$ so $m = \frac{F}{G}$ **gravitational mass**
 - In terms of the acceleration
 experienced when a constant force is
 exerted on the mass.
 $F = ma$ so $m = \frac{F}{a}$ **inertial mass**

- (b) (i) from the gradient $a = \frac{0.8}{0.5} = 1.6 \text{ m s}^{-2}$
- (ii) distance = area
 $= \frac{1}{2} \times 0.5 \times 0.8 + 0.8 \times 11$
 $+ \frac{1}{2} \times 0.5 \times 0.8 = 9.2 \text{ m}$

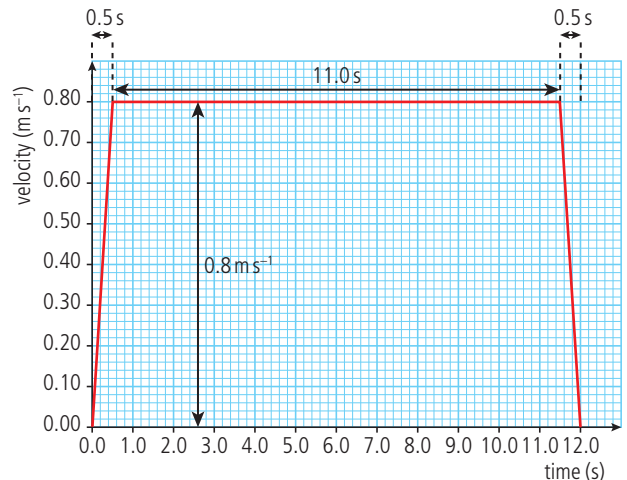

- (ii) Minimum work = gain in PE $= mgh$
 $= 250 \times 10 \times 9.2$
 $= 23000 \text{ J}$
- (iv) power $= \frac{\text{work done}}{\text{time}} = \frac{23000}{12} = 1916 \text{ W}$
 $\approx 1.9 \text{ kW}$
- (v) efficiency $= \frac{\text{power out}}{\text{power in}} \times 100\%$
 $= \frac{1.9}{5} \times 100\% = 38\%$
- (c) On the original graph, velocity changed
 instantly
 $\Rightarrow a = \frac{\Delta V}{0} = \infty$
 This cannot happen; the changes happen
 over time.

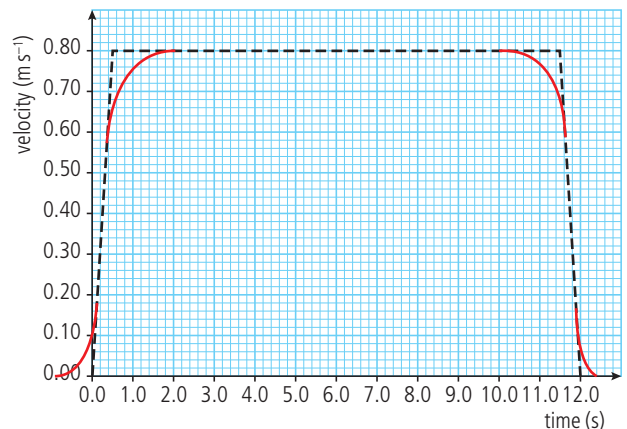

- (d) (i) Since velocity is constant the force must be balanced.

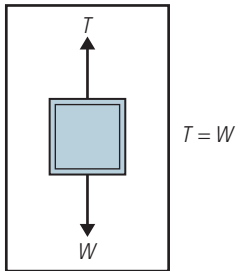

- (ii) Since elevator is going up and slowing down acceleration is down so $W > T$.

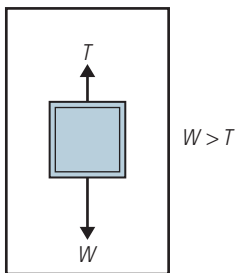

W should be the same in each diagram, it is T that changes. Good idea to write which force is bigger in case diagram isn't clear.

- (e) The reading on the scales is the upward force on the person; this is bigger than W when accelerating up but equal to W when velocity is constant.

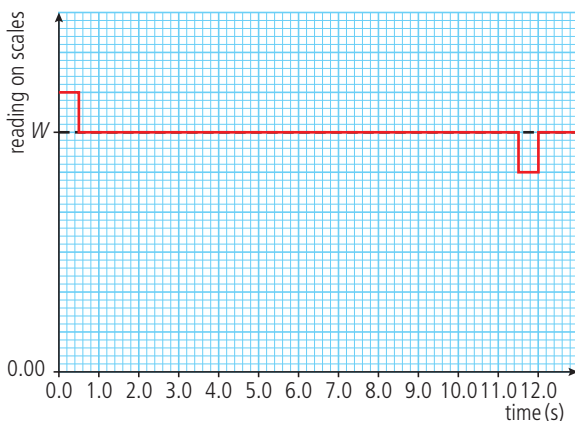

- (f) $0 \rightarrow 0.5$ s
Electrical energy changes to PE + KE
 $0.5 \rightarrow 11.5$ s
Electrical energy changes to PE
 $11.5 \rightarrow 12.0$ s
KE + electrical energy changes to PE

On the way down PE is converted first to KE then to heat.

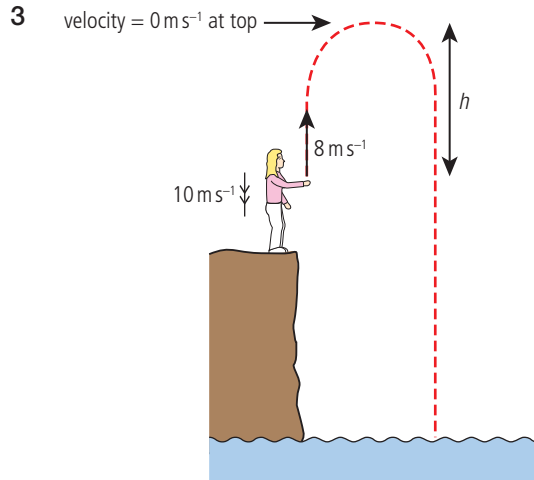

- (a) (i) Using $v^2 = u^2 + 2as \Rightarrow s = \frac{v^2 - u^2}{2a}$

$$u = 8 \text{ ms}^{-1}$$

$$v = 0 \text{ ms}^{-1}$$

$$a = -10 \text{ ms}^{-2}$$

$$d = h$$

$$h = \frac{0^2 - 8^2}{-2 \times 10} = 3.2 \text{ m}$$

- (ii) Using $a = \frac{v-u}{t} \Rightarrow t = \frac{v-u}{a}$

$$t = \frac{-8}{-10} = 0.8 \text{ s}$$

- (b) (alternative method)

Time to reach sea = 3.0 s

using $s = ut + \frac{1}{2}at^2$

$$u = 8.0 \text{ ms}^{-1}$$

$$t = 3.0 \text{ s}$$

$$a = -10 \text{ ms}^{-2}$$

$$s = 8 \times 3 - \frac{1}{2} \times 10 \times 3^2$$

$$= 24 - 45$$

$$= -21 \text{ m}$$

i.e. 21 m below start.

So the cliff = 21 m high

- 4 (a) Newton's third law: If body A exerts a force on body B then body B must exert an equal and opposite force on body A.
- (b) Law of conservation of momentum: for a system of isolated bodies (i.e. no external forces acting) the total momentum is constant.

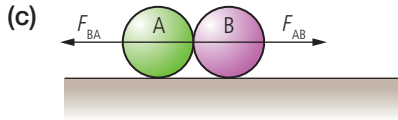

Should be the same length acting through the centre of the spheres.

(d) (i) $F_{AB} = \frac{\text{(change in } mv)_B}{\text{time}} = \frac{mv_B - 0}{t}$
 $F_{AB} = \frac{mv_B}{t}$

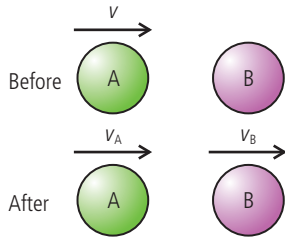

(ii) $F_{BA} = \text{rate of change of momentum}$
 $= \frac{\text{(change in } mv)_A}{\text{time}} = \frac{mv_A - mv}{t}$
 $F_{BA} = \frac{m(v_A - v)}{t}$

(e) According to Newton's third law

$$F_{AB} = -F_{BA}$$

$$= \frac{mv_B}{t} = \frac{-m(v_A - v)}{t}$$

$$mv_B = -mv_A + mv$$

$$mv_B + mv_A = mv$$

(f) If KE conserved then initial KE = final KE

$$\frac{1}{2} mv^2 = \frac{1}{2} mv_A^2 + \frac{1}{2} mv_B^2$$

$$v^2 = v_A^2 + v_B^2$$

From conservation of momentum we know that $v = v_A + v_B$

If v_A is at rest then $v_A = 0$ and B travels at v then $v_B = v$

$$\text{So } v^2 = 0^2 + v^2 \text{ and } v = 0 + v$$

which means that this is a possible outcome

In fact it is the only solution.

5 (a) Linear momentum = mass \times velocity

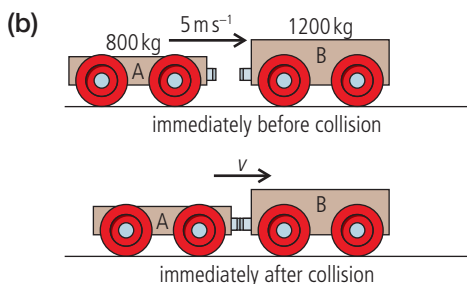

(i) Applying conservation of momentum
 momentum before = momentum after
 $800 \times 5.0 = (800 + 1200)v$
 $4000 = 2000v$
 $v = 2.0 \text{ m s}^{-1}$

(ii) Initial KE = $\frac{1}{2} \times 800 \times 5^2 = 10000 \text{ J}$
 Final KE = $\frac{1}{2} \times 2000 \times 2^2 = 4000 \text{ J}$
 Loss of KE = $10000 - 4000 = 6000 \text{ J}$

(c) When the trucks collide heat and sound are produced.

6 (a) (i) $PE = mgh$
 $mg = \text{weight of man} = 700 \text{ N}$
 height from A to B = $30 \times \sin 40^\circ$
 $= 19.3 \text{ m}$

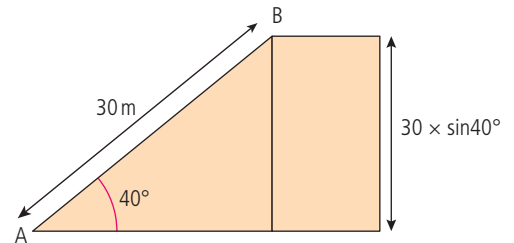

gain in PE = $700 \times 19.3 = 13500 \text{ J}$

(ii) If 48 people go up per minute the total increase in PE = 48×13500
 $= 6.48 \times 10^5 \text{ J}$

(iii) Assume that people stand still on the escalator and that they all weigh 700 N.

(b) (i) $\text{power} = \frac{\text{work done}}{\text{time}} = \frac{\text{gain in PE}}{\text{time}}$
 $= \frac{6.2 \times 10^5}{60} = 1 \times 10^4 \text{ W}$

$$\text{efficiency} = \frac{P_{\text{out}}}{P_{\text{in}}} \Rightarrow P_{\text{in}} = 15 \text{ kW}$$

(ii) The escalator is a continuous band; it goes up on the outside and down on the inside.

(c) Since the efficiency will be less than 100% due to friction etc. the power in will be greater than useful work done.

Unless they are small children running up the escalator. ☺

- 7 (a) The total momentum of a system of isolated bodies is always constant.

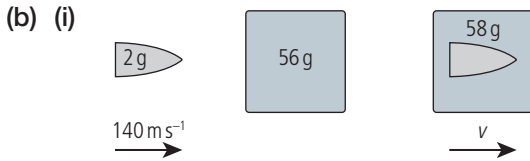

Conserving momentum
 $56 \times 0 + 2 \times 140 = 58 \times v$
 $\frac{280}{58} = v = 4.8 \text{ m s}^{-1}$

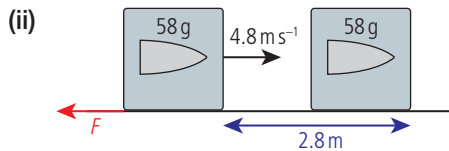

As block slows work done against friction = average $F \times$ distance moved in direction of force
 Work done against friction will equal the KE lost = $\frac{1}{2} mv^2 = \frac{1}{2} \times 0.058 \times 4.8^2 = 0.7 \text{ J}$
 So average $F \times 2.8 = 0.7$
 average force = 0.24 N

- (c) (i) Assuming vertical component of velocity is uniform we can use
 $s = ut + \frac{1}{2} at^2$
 $u = 0$ so $\sqrt{\frac{2s}{a}} = \sqrt{\frac{2 \times 0.85}{10}} = 0.41 \text{ s}$
 Horizontal velocity is constant = 4.3 m s^{-1}
 Horizontal distance = $vt = 4.3 \times 0.41 = 1.8 \text{ m}$

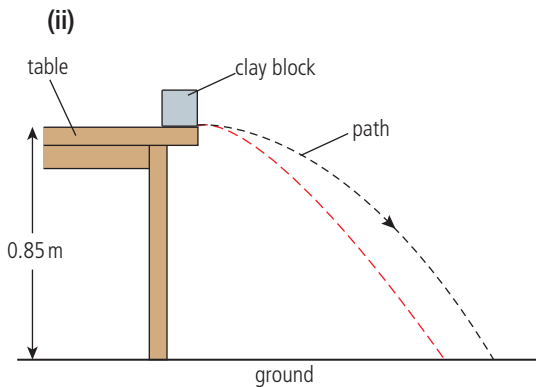

Challenge yourself

- 1 First draw a diagram

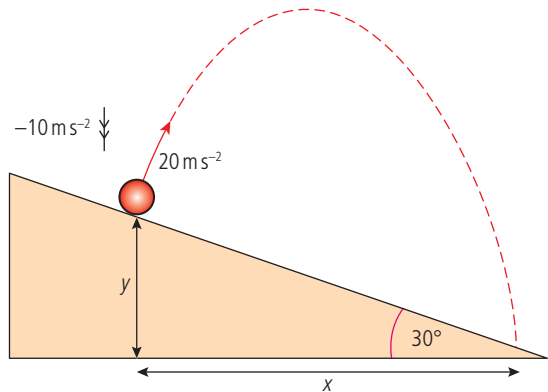

Taking components of the motion

Horizontal

$$x = 20 \times \sin 30^\circ \times t$$

Vertical

$$y = 20 \times \cos 30^\circ \times t - \frac{1}{2} \times 10 \times t^2$$

We also know that $\frac{y}{x} = -\tan \theta$ (negative because the value of y is negative)

Dividing

$$\frac{y}{x} = \frac{20 \times \cos 30^\circ \times t - \frac{1}{2} \times 10 \times t^2}{20 \times \sin 30^\circ \times t} = -\tan 30^\circ$$

$$t = 4.62 \text{ s}$$

$$\text{so } x = 46.2 \text{ m}$$

$$y = -26.7 \text{ m}$$

$$\text{Distance down slope} = \sqrt{46.2^2 + (-26.7)^2} = 53 \text{ m}$$

- 2

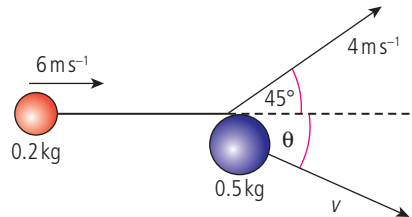

Taking components of the momentum

Horizontal:

$$0.2 \times 6 = 0.2 \times 4 \times \cos 45^\circ + 0.5 \times v \cos \theta$$

$$\text{So } v \cos \theta = 1.27$$

Vertical:

$$0.2 \times 4 \times \sin 45^\circ = 0.5 \times v \sin \theta$$

$$\text{So } v \sin \theta = 1.13$$

$$\frac{v \sin \theta}{v \cos \theta} = \frac{1.13}{1.27} = \tan \theta$$

$$\theta = -41.7^\circ$$

$$v = \frac{1.27}{\cos(-41.7^\circ)} = 1.7 \text{ m s}^{-1}$$

Worked solutions

Chapter 3

Exercises

- 1 (a) 1 mole of copper has mass = 63.54 g
= 0.06354 kg

$$\text{Density, } \rho = \frac{\text{mass}}{\text{volume}} \text{ so } V = \frac{M}{\rho}$$

$$V = \frac{0.06354}{8920} = 7.123 \times 10^{-6} \text{ m}^3$$

- (b) 1 mole contains 6.022×10^{23} atoms (from definition)

- (c) If the volume of 6.022×10^{23} atoms is $7.123 \times 10^{-6} \text{ m}^3$ then the volume of 1 atom
= $\frac{7.123 \times 10^{-6}}{6.022 \times 10^{23}} \text{ m}^3 = 1.183 \times 10^{-29} \text{ m}^3$

- 2 Density, $\rho = \frac{\text{mass}}{\text{volume}}$

$$\text{Volume} = 10 \text{ cm}^3$$

$$= 10 \times 10^{-6} \text{ m}^3$$

$$\text{Density} = 2700 \text{ kg m}^{-3}$$

$$\text{mass} = V \times \rho = 10 \times 10^{-6} \times 2700$$

$$\text{mass} = 2.7 \times 10^{-2} \text{ kg} = 27 \text{ g}$$

- 3 (a) Block has PE = $mgh = 10 \times 9.8 \times 40$
= $3.92 \times 10^3 \text{ J}$

- (b) This PE will all be converted to heat so
heat to floor + block = $3.92 \times 10^3 \text{ J}$

- 4 Mass of car in example 1 = 1000 kg so if
 $v = 60 \text{ m s}^{-1}$

$$\text{KE} = \frac{1}{2}mv^2 = \frac{1}{2} \times 1000 \times 60^2$$

$$= 1.8 \times 10^6 \text{ J}$$

- 5 If the speed is constant then rate of change of
PE = gain in energy of surroundings

$$\frac{mg\Delta h}{\Delta t} = mgv$$

$$= 75 \times 9.8 \times 50$$

$$= 3.7 \times 10^4 \text{ J}$$

6

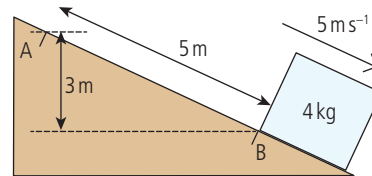
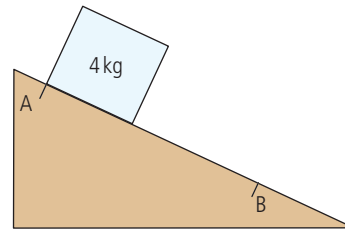

Loss of PE = gain in KE + WD against friction

$$4 \times 9.8 \times 3 = \frac{1}{2} \times 4 \times 5^2 + W$$

$$W = 117.7 - 50 = 67.7 \text{ J}$$

work = force \times distance in direction of force

$$\text{distance travelled} = 5 \text{ m}$$

$$67.7 = F \times 5$$

$$F = 13.5 \text{ N}$$

7

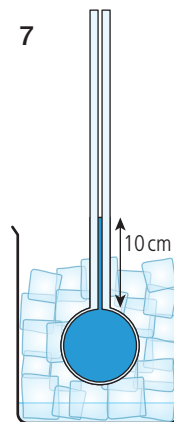

melting ice

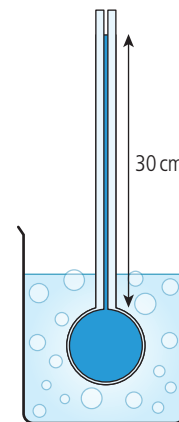

boiling water

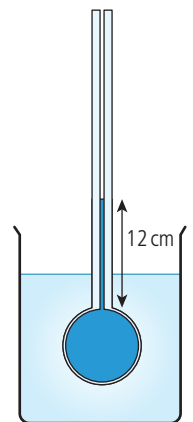

unknown temperature

A change in height of 20 cm is equivalent to a
change in temperature of 100°C

$$\frac{100}{20} = 5^\circ\text{C cm}^{-1}$$

The unknown temperature is 2 cm above zero;

this is equivalent to $2 \text{ cm} \times 5^\circ\text{C cm}^{-1} = 10^\circ\text{C}$

Alternatively using $\frac{L_T - L_0}{L_{100} - L_0} \times 100$

$$T = \frac{12 - 10}{30 - 10} \times 100 = 10^\circ\text{C}$$

- 8 (a) Average KE of air molecules = $\frac{3}{2}kT$
 (This assumes air is an ideal gas which it isn't, but it gives an approximate answer)
 temperature in K = $273 + 20 = 293$ K
 Average KE = $\frac{3}{2} \times 1.38 \times 10^{-23} \times 293$
 $= 6 \times 10^{-21}$ J
- (b) molar mass of air = 29 g mol^{-1}
 mass of 1 molecule = $\frac{29}{6} \times 10^{23}$
 $= 4.8 \times 10^{-23} \text{ g} = 4.8 \times 10^{-26} \text{ kg}$
- (c) $KE = \frac{1}{2}mv^2$
 $v = \sqrt{\frac{2KE}{m}} = \sqrt{\frac{2 \times 6 \times 10^{-21}}{4.8 \times 10^{-26}}} = 500 \text{ ms}^{-1}$
- 9 From definition $Q = C\Delta\theta$
 Heat lost = $210 \times 10^3 \times 2$
 $Q = 420 \text{ kJ}$
- 10 (a) A 1 kW heater will deliver 10^3 J per second
 so if it's on for 1 hour:
 heat delivered = $60 \times 60 \times 10^3 = 3.6 \times 10^6$ J
- (b) From definition $C = \frac{Q}{\Delta\theta}$
 the room is heated from 10°C to 20°C
 so $\Delta\theta = 10^\circ\text{C}$
 So for the room, $C = \frac{3.6 \times 10^6}{10}$
 $= 3.6 \times 10^5 \text{ J}^\circ\text{C}$
- (c) Some heat will be lost to the outside.
- 11 From table, $C_{\text{copper}} = 380 \text{ J/kg}^\circ\text{C}$
 So $Q = 0.25 \times 380 \times (160 - 20)$
 $= 1.33 \times 10^4$ J
- 12 (a) Density, $\rho = \frac{M}{V}$, $M = \rho \times V$
 1 litre = $1000 \text{ cm}^3 = 1000 \times 10^{-6} \text{ m}^3$
 $= 10^{-3} \text{ m}^3$
 $M = 1000 \times 10^{-3} = 1 \text{ kg}$
- (b) $Q = mc\Delta\theta = 1 \times 4200 \times (100 - 20)$
 $= 3.36 \times 10^5$ J
- (c) $1 \text{ kW} \Rightarrow 1000 \text{ J per second}$
 So time taken = $\frac{3.36 \times 10^5}{1000} = 336 \text{ s}$
 or power = $\frac{\text{energy}}{\text{time}}$
- 13 (a) power = $\frac{\text{energy}}{\text{time}}$ so energy = power \times time
 energy = $500 \times 10 \times 60$ (time in seconds)
 $= 3 \times 10^5$ J

- (b) Energy added = $3 \times 10^5 \text{ J} = mc\Delta\theta$
 so $\Delta\theta = \frac{3 \times 10^5}{0.5 \times 900} = 667^\circ\text{C}$
 so if initial temperature = 20°C
 final temperature = 687°C

- 14 (a) Initial KE = $\frac{1}{2}mv^2 = \frac{1}{2} \times 1500 \times 20^2$
 $= 3 \times 10^5$ J
 Final KE = 0 J so KE lost = 3×10^5 J
- (b) 75% of 3×10^5 J
 $= \frac{75}{100} \times 3 \times 10^5 = 2.25 \times 10^5$ J
- (c) $Q = mc\Delta\theta \Rightarrow \Delta\theta = \frac{Q}{mc}$
 $= \frac{2.25 \times 10^5}{10 \times 440} = 51^\circ\text{C}$
- 15 (a) 8 litre/min = 8 kg/min since 1 litre has a mass of 1 kg.
 So in 10 minutes 80 kg of water is used.
- (b) Using $Q = mc\Delta\theta$
 $Q = 80 \times 4200 \times (50 - 10)$
 $= 1.34 \times 10^7$ J
- 16 From definition $Q = ml$
 (fusion since water is turning into ice)
 Heat released, $Q = 1 \times 10^6 \times 3.35 \times 10^5$ J
 $= 3.35 \times 10^{11}$ J
- 17 To change 400g of water at 100°C into steam
 requires $0.4 \times 2.27 \times 10^6 = 9.08 \times 10^5$ J
 If power of heater = 800 W
 then since $P = \frac{\text{energy}}{\text{time}}$, $t = \frac{E}{P} = \frac{9.08 \times 10^5}{800}$
 $t = 1.135 \times 10^3 \text{ s} = 19 \text{ min.}$

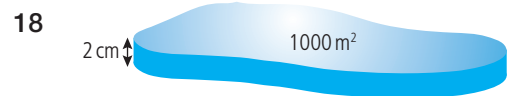

- (a) Volume = $1000 \times 2 \times 10^{-2} = 20 \text{ m}^3$
 Density, $\rho = \frac{M}{V} \Rightarrow M = V\rho = 20 \times 920$
 $= 1.84 \times 10^4$ kg
- (b) $Q = ml = 1.84 \times 10^4 \times 3.35 \times 10^5$
 $= 6.16 \times 10^9$ J
- (c) $P = \frac{Q}{t} = \frac{6.16 \times 10^9}{5 \times 60 \times 60} = 3.42 \times 10^5$ W
- (d) Power per $\text{m}^2 = \frac{3.42 \times 10^5}{1000}$
 $= 3.42 \times 10^2 \text{ Wm}^{-2}$

19

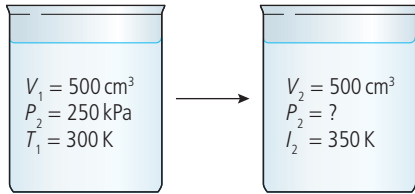

$$\frac{P_1 V_1}{T_1} = \frac{P_2 V_2}{T_2}$$

$$\frac{250 \times 500}{300} = \frac{P_2 \times 500}{350}$$

$$P_2 = \frac{250 \times 350}{300} = 292 \text{ kPa}$$

20

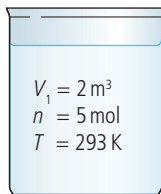

(a) $PV = nRT$

$$P = \frac{nRT}{V} = \frac{5 \times 8.31 \times 293}{2}$$

$$P = 6 \text{ kPa}$$

(b) If half of gas leaks, $n = 2.5 \text{ mol}$

$$P = 3 \text{ kPa}$$

21

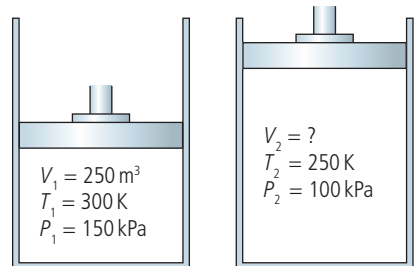

$$\frac{P_1 V_1}{T_1} = \frac{P_2 V_2}{T_2} \Rightarrow \frac{150 \times 250}{300} = \frac{100 \times V_2}{250}$$

$$V_2 = \frac{150 \times 250 \times 250}{300 \times 100}$$

$$V_2 = 312.5 \text{ m}^3$$

22

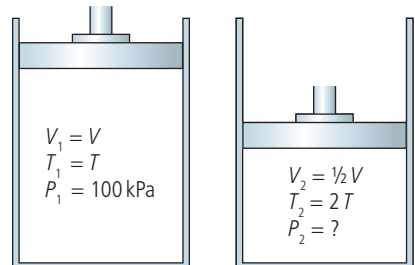

$$\frac{P_1 V_1}{T_1} = \frac{P_2 V_2}{T_2} \Rightarrow \frac{100 \times V}{T} = \frac{P_2 \times \frac{1}{2}V}{2T}$$

$$P_2 = \frac{2 \times 100}{\frac{1}{2}} = 400 \text{ kPa}$$

Practice questions

1

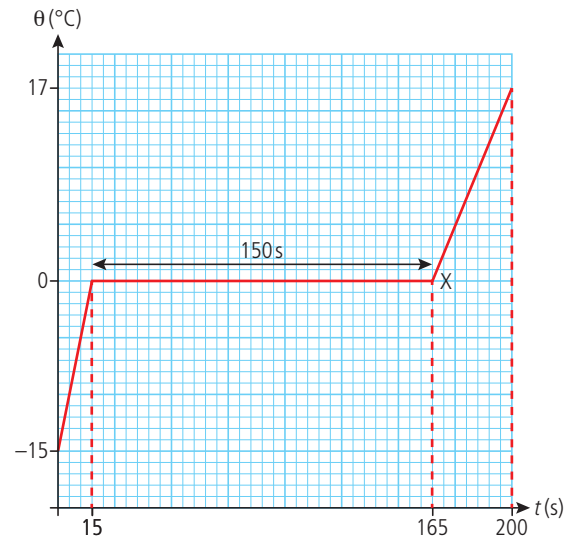

(a) Ice melts when temperature is constant 0°C . All melted at 165s.

(b) Heat goes to increase PE not KE so temperature remains constant.

(c) (i) For last part of graph, water is heated from 0 to 15°C in 30s

$$Q = mc\Delta\theta \Rightarrow \text{heat supplied}$$

$$= 0.25 \times 4200 \times 15 = 1.79 \times 10^4 \text{ J}$$

$$\text{Power} = \frac{Q}{t} = \frac{1.79 \times 10^4}{30}$$

$$= 525 \text{ W} \approx 530 \text{ W}$$

(ii) Time to heat ice from -15 to $0^\circ\text{C} = 15 \text{ s}$

$$Q = \text{power} \times t = 530 \times 15 = 7950 \text{ J}$$

$$Q = mc\Delta\theta$$

$$C = \frac{7950}{0.25 \times 15} = 2.1 \times 10^3 \text{ J kg}^{-1}$$

(iii) Takes 150s to melt 0.25kg of ice

$$\text{Heat given } Q = 530 \times 150 = 79500 \text{ J}$$

$$= mL$$

$$L = \frac{79500}{0.25} = 3.2 \times 10^5 \text{ J kg}^{-1}$$

2 (a) When a liquid evaporates the molecules with most energy escape from the surface, resulting in a reduction in the average KE and hence temperature. If heat is added temperature will remain constant.

(b) Blowing across the surface reduces humidity of surrounding air; increased temperature of liquid; increased surface area of liquid

(c) Heat lost when water turns into ice

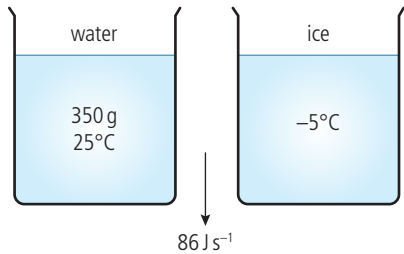

$$= mc\Delta\theta_{\text{water}} + mL_{\text{water-ice}} + mc\Delta\theta_{\text{ice}}$$

$$0.35 \times 4200 \times 25 + 0.35 \times 3.3 \times 10^5 + 0.35 \times 2.1 \times 10^3$$

$$= 156000 \text{ J}$$

$$\text{Power} = \frac{Q}{t}$$

$$t = \frac{Q}{P} = \frac{156000}{86} = 1800 \text{ s}$$

3 (a) In this context thermal energy is the internal energy of the molecules of the runner. This can be KE and PE. Increased thermal energy will increase the average KE of the molecules which increases the temperature, in other words the runner becomes hot.

(b) (i) Energy generated = power \times time
 $= 1200 \times 3600 = 2.2 \times 10^6 \text{ J}$

(ii) $Q = mc\Delta\theta$

$$\Delta\theta = \frac{Q}{mc} = \frac{2.2 \times 10^6}{70 \times 4200} = 7.5 \text{ K}$$



$1200 \text{ J s}^{-1} \times 1800$

(c) Convection

Conduction

Radiation This is no longer on the syllabus.

(d) (i) The molecules with greatest KE leave the surface resulting in a decrease in average KE and hence temperature.

(ii) Total energy generated = $2.2 \times 10^6 \text{ J}$
 50% lost in evaporation = $1.1 \times 10^6 \text{ J}$
 This energy goes to latent heat of vaporization $Q = mL$

$$m = \frac{Q}{L} = \frac{1.1 \times 10^6}{2.26 \times 10^6} = 487 \text{ g}$$

(iii) Wind

Skin temperature

Humidity

Air temperature

Area of skin

Clothing

4 (a) (i) Constant speed so resistive force = component of mg acting down the slope

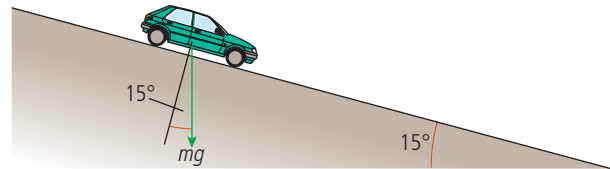

$$mg \sin 15^\circ = 960 \times 9.8 \times 0.259$$

$$= 2.4 \text{ kN}$$

(ii) $\text{KE} = \frac{1}{2}mv^2 = \frac{1}{2} \times 960 \times 9^2 = 39 \text{ kJ}$

(b) Work done = average force \times distance

Work done against braking force

= loss of KE = 39 kJ = average force \times 15 m

$$\text{average force} = \frac{39000}{15} = 2.6 \text{ kN}$$

(c) Energy given to brakes = 39 kJ

This causes the brakes to get hot so KE

lost = thermal energy gained = $mc\Delta T$

Two brakes so total mass = 10.4 kg

$$39000 = 10.4 \times 900 \times \Delta T$$

$$\Delta T = 4.2 \text{ K}$$

This assumes no heat lost and all KE converted to heat not sound.

5 (a) (i) The molecules of an ideal gas are considered to be small perfectly elastic spheres moving in random motion with no forces between them. Small and elastic is mentioned in the question so

1. Motion is random

2. No forces between molecules except when colliding

Challenge yourself

1

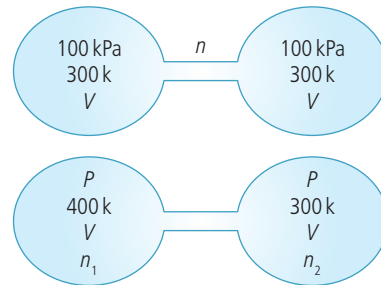

When first filled and joined we can treat the two flasks as one container. Applying the ideal gas equation, $PV = nRT$, we get $100 \times 2V = nR \times 300$. After one flask is heated we have to treat them separately but since they are connected the pressure is the same.

$$PV = n_1 R \times 400$$

$$PV = n_2 R \times 300$$

The total number of moles n is the same before and after so

$$n = n_1 + n_2$$

$$\text{substituting gives } \frac{200V}{300R} = \frac{PV}{400R} + \frac{PV}{300R}$$

$$\frac{2}{3} = \left(\frac{1}{400} + \frac{1}{300} \right) P$$

$$P = 114.3 \text{ kPa}$$

(ii) The molecules of an ideal gas have no forces between them so changing their position does not require work to be done; gas molecules therefore have no PE; this implies that the internal energy of a gas is related to the average KE of the molecules. If energy is added to the gas, temperature increases so we see that temperature is related to the average KE.

(b) (i) Using $PV = nRT$

$$T = 290 \text{ K}$$

$$P = 4.8 \times 10^5 \text{ Pa}$$

$$V = 9.2 \times 10^{-4} \text{ m}^3$$

$$n = \frac{PV}{RT} = \frac{4.8 \times 10^5 \times 9.2 \times 10^{-4}}{8.3 \times 290} = 0.18 \text{ mol}$$

(ii) If temperature constant $P_1 V_1 = P_2 V_2$
 $4.8 \times 10^5 \times 9.2 \times 10^{-4} = P_2 \times 2.3 \times 10^{-4}$

$$P_2 = \left(\frac{9.2}{2.3} \right) \times 4.8 \times 10^5 = 19 \times 10^5 \text{ Pa}$$

(iii) If volume is constant $\frac{P_1}{T_1} = \frac{P_2}{T_2}$

$$P_1 = 19 \times 10^5 \text{ Pa}$$

$$T_1 = 290 \text{ K}$$

$$P_2 = ?$$

$$T_2 = 420 \text{ K}$$

$$P_2 = 19 \times 10^5 \times \frac{420}{290} = 2.8 \times 10^6 \text{ Pa}$$

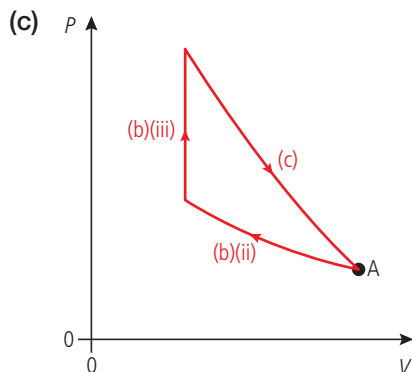

Worked solutions

Chapter 4

Exercises

1 (a) distance = $2\pi r = 2\pi \times 5 = 31.4$ m

(b) displacement = 0 m

(c) speed = 2 m s^{-1}

$$t = \frac{d}{\text{speed}} = \frac{31.4}{2} = 15.7 \text{ s}$$

(d) $f = \frac{1}{T} = \frac{1}{15.7} = 6.4 \times 10^{-2} \text{ Hz}$

(e) $\omega = 2\pi f = 0.4 \text{ rad s}^{-1}$

(f) $a = \frac{v^2}{r} = \omega^2 r = 0.8 \text{ m s}^{-2}$

2 Centripetal force = $\frac{mv^2}{r} = \frac{1000 \times \left(\frac{30000}{3600}\right)^2}{50} = 1389 \text{ N}$

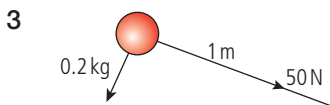

Maximum centripetal force = $50 \text{ N} = \frac{mv^2}{r}$

$$v^2 = \frac{50 \times 1}{0.2} \Rightarrow v = 15.8 \text{ m s}^{-1}$$

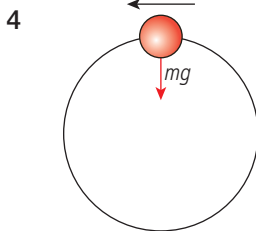

Minimum speed when $\frac{1}{2}mv^2 = mgh$,

so $\frac{1}{2}mv^2 = mg(2r)$, $v^2 = 4gr$

$$v = \sqrt{4gr} = \sqrt{4 \times 9.8 \times 5} = 14 \text{ m s}^{-1}$$

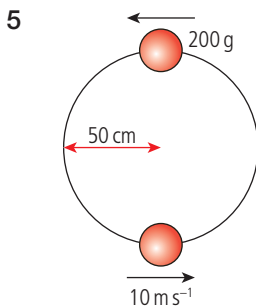

(a) At the top some of the KE has turned to PE

Gain in PE = $mgh = 0.2 \times 9.8 \times 2 \times 0.5 = 1.96 \text{ J}$

KE at bottom = $\frac{1}{2}mv^2 = \frac{1}{2} \times 0.2 \times 10^2 = 10 \text{ J}$

KE at top = $10 - 1.96 = 8.04 \text{ J}$

$$v = \sqrt{\frac{2\text{KE}}{m}} = \sqrt{\frac{2 \times 8.04}{0.2}} = 9 \text{ m s}^{-1}$$

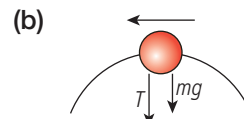

At the top $T + mg = \frac{mv^2}{r}$

$$T = \frac{mv^2}{r} - mg = \left(\frac{0.2 \times 9^2}{0.5}\right) - 0.2 \times 9.8 = 30 \text{ N}$$

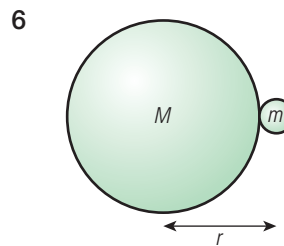

From Newton's universal law $F = \frac{GMm}{r^2}$

But the weight of an object = mg

$$mg = \frac{GMm}{r^2}$$

acceleration due to gravity, $g = \frac{GM}{r^2}$

for the Moon $g = \frac{6.67 \times 10^{-11} \times 7.32 \times 10^{22}}{(1.74 \times 10^6)^2}$

$$g = 1.61 \text{ m s}^{-2}$$

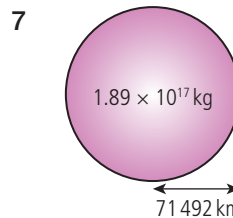

Using the equation for gravitational field strength

of a spherical object $g = \frac{GM}{r^2}$

$$g = \frac{6.67 \times 10^{-11} \times 1.89 \times 10^{17}}{(7.1492 \times 10^7)^2}$$

$$= 24.7 \text{ N kg}^{-1}$$

8

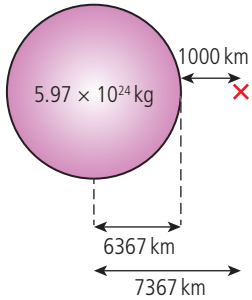

Using the formula for the gravitational field due to a spherical mass $g = \frac{GM}{r^2}$ where $r = 7367$ km as shown

$$g = \frac{6.67 \times 10^{-11} \times 5.97 \times 10^{24}}{(7.367 \times 10^6)^2}$$

$$g = 7.34 \text{ Nkg}^{-1}$$

9

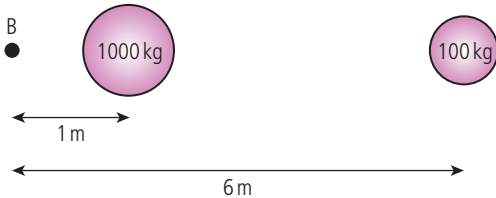

Since both masses are on the same side of B then the two fields are in the same direction. The field vectors will therefore simply add. Using the equation for the field due to a sphere

$$g = \frac{GM}{r^2}$$

$$\text{Field due to } 1000 \text{ kg} = \frac{6.67 \times 10^{-11} \times 1000}{1^2}$$

$$= 6.67 \times 10^{-8} \text{ Nkg}^{-1}$$

$$\text{Field due to } 100 \text{ kg} = \frac{6.67 \times 10^{-11} \times 100}{6^2}$$

$$= 0.018 \times 10^{-8} \text{ Nkg}^{-1}$$

$$\text{Total field} = 6.67 + 0.018 = 6.69 \times 10^{-8} \text{ Nkg}^{-1}$$

10

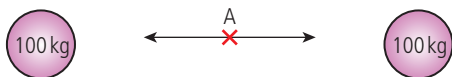

If masses are equal the fields will be equal and opposite as shown.

$$\text{Resultant field} = 0 \text{ Nkg}^{-1}$$

11 $V_C = gh_C = 10 \times 14 = 140 \text{ Jkg}^{-1}$

$$V_D = gh_D = 10 \times 11 = 110 \text{ Jkg}^{-1}$$

Potential difference between C and D

$$= 140 - 110 = 30 \text{ Jkg}^{-1}$$

12 Work done from D to C = $\Delta V \times m = 30 \times 3$

$$= 90 \text{ J}$$

13 PE = $mgh = 3 \times 10 \times 8 = 240 \text{ J}$

2

14 A and E are at the same height so no potential difference.

15 No work is done since there is no change in potential.

16

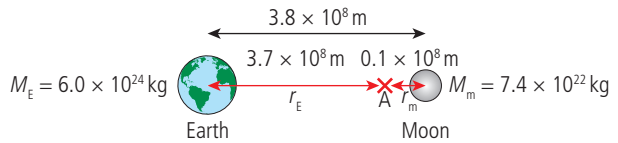

(a) Potential at A = $\frac{GM_E}{r_E} + \frac{GM_m}{r_m}$

$$= 6.67 \times 10^{-11} \left(\frac{6 \times 10^{24}}{3.7 \times 10^8} + \frac{7.4 \times 10^{22}}{0.1 \times 10^8} \right)$$

$$= 6.67 \times 10^{-11} \times (1.6 \times 10^{16} + 7.4 \times 10^{15})$$

$$= 1.6 \text{ MJkg}^{-1}$$

(b) PE of 2000 kg rocket = $v \times m$

$$= 1.6 \times 10^6 \times 2000 = 3.1 \times 10^9 \text{ J}$$

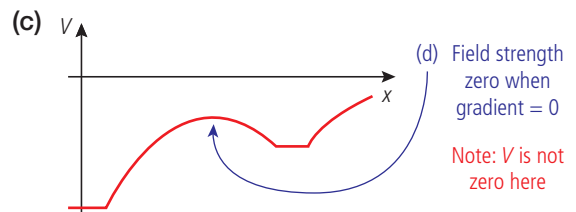

(d) Field strength zero when gradient = 0

Note: V is not zero here.

17

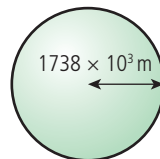

$$\text{mass} = 7.4 \times 10^{22} \text{ kg}$$

$$V_{\text{escape}} = \sqrt{\frac{2GM}{R}}$$

$$= \sqrt{\frac{2 \times 6.67 \times 10^{-11} \times 7.4 \times 10^{22}}{1738 \times 10^3}}$$

$$= 2.38 \times 10^3 \text{ ms}^{-1}$$

18 Hydrogen is a small atom so its mean velocity would be much higher than air molecules; some hydrogen atoms would be travelling faster than the escape velocity.

19 To be black hole $V_{\text{escape}} = 3 \times 10^8 \text{ ms}^{-1}$

$$= \sqrt{\frac{2GM}{R}}$$

$$R = \frac{2GM}{(3 \times 10^8)^2}$$

$$= \frac{2 \times 6.67 \times 10^{-11} \times 2 \times 10^{30}}{(3 \times 10^8)^2} = 3 \text{ km}$$

20 $V_{\text{escape}} = \sqrt{\frac{2GM}{R}}$ where R = distance from rocket to centre of Earth = (6400 + 100 000) km

$$V_{\text{escape}} = \sqrt{\frac{2 \times 6.67 \times 10^{-11} \times 6 \times 10^{24}}{1.064 \times 10^8}} = 2.74 \text{ km s}^{-1}$$

21

radius/ 10^{10} km	period days	radius ³ / (10^{10} km) ³	period ² days ²
5.79	88	194.104539	7744
10.8	224.7	1259.712	50490.09
15	365.3	3375	133444.09
22.8	687	11852.352	471969
77.8	4330	470910.952	18748900
143	10700	2924207	114490000
288	30600	23887872	936360000
450	59800	91125000	3576040000

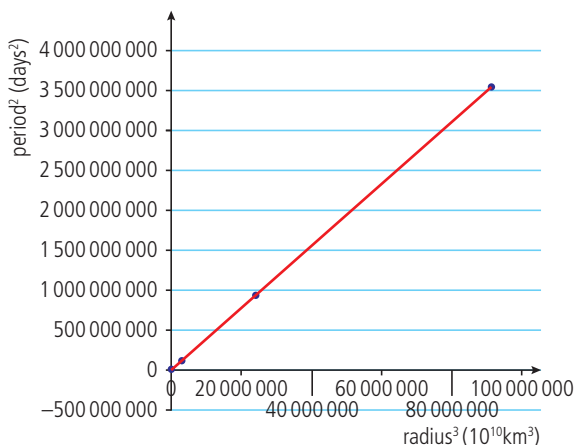

This is plotted from the data in Chapter 12. The scale is very big so the smaller numbers are not visible.

22 For a TV satellite $T = 1 \text{ day} = 24 \times 60 \times 60 = 86400 \text{ s}$

From Kepler's law $\frac{T^2}{r^3} = \frac{4\pi^2}{GM} \Rightarrow r^3 = \frac{T^2 GM}{4\pi^2}$

$$= \frac{86400^2 \times 6.67 \times 10^{-11} \times 6 \times 10^{24}}{4\pi^2} = 7.6 \times 10^{22}$$

$$r = 4.2 \times 10^7 \text{ m} \sim 7R_E \quad \text{Use logs to find } \sqrt[3]{}$$

23 Orbit radius = 6400 + 400 km = $6.8 \times 10^6 \text{ m}$

$$T^2 = \frac{r^3 4\pi^2}{GM} = \frac{(6.8 \times 10^6)^3 \times 4\pi^2}{6.67 \times 10^{-11} \times 6 \times 10^{24}} = 3.1 \times 10^7$$

$$T = 5.57 \times 10^3 \text{ s} = 1.5 \text{ hours}$$

24 (a) $\text{KE} = \frac{GMm}{2r} = 5.9 \times 10^{10} \text{ J}$

(b) $\text{PE} = \frac{-GMm}{r} = -1.2 \times 10^{11} \text{ J}$

(c) Total = $\text{KE} + \text{PE} = -6.1 \times 10^{10} \text{ J}$

Practice questions

- 1 (a) Velocity is a vector so as the direction of the car changes, velocity must change. Acceleration is the rate of change of velocity so if velocity changes the car must accelerate.
- (b) (ii) Weight and the normal force both act downwards. **Not centripetal force; this is the resultant.**

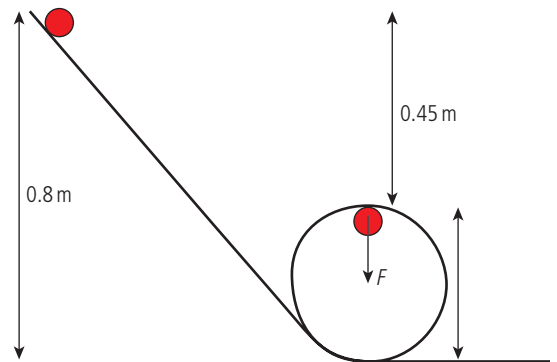

- (iii) If no energy loss then loss of PE = gain in KE.

$$mg\Delta h = \frac{1}{2}mv^2$$

$$\Rightarrow 10 \times (0.8 - 0.35) = \frac{1}{2}v^2$$

$$\Rightarrow v = \sqrt{9} = 3 \text{ m s}^{-1}$$

- (iv) We know that if moving in a circle

$$F = \frac{mv^2}{r}$$

$$\Rightarrow F = \frac{0.05 \times 3^2}{0.35/2}$$

Now this force is caused by normal force and weight

$$\Rightarrow 2.6 = N + W$$

where $W = 0.5 \text{ N}$

so $2.6 = N + 0.5$

$$N = 2.6 - 0.5 = 2.1 \text{ N}$$

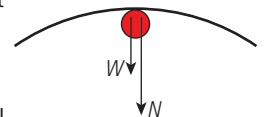

- 2 (a) Coefficient of friction is defined by the equation $F = \mu R$ so μ is the ratio of
- $$\frac{\text{friction force}}{\text{normal reaction force}}$$

- (b) (i) Since the person is not moving relative to the wall, the friction would be static friction.

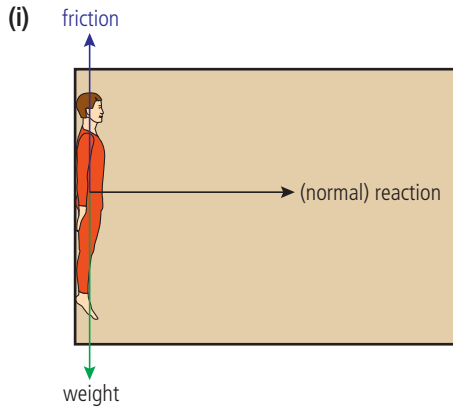

- (c) (i) The minimum speed is such that friction = weight

$$mg = \mu R$$

$$\text{So } R = \frac{mg}{\mu} = 80 \times \frac{10}{0.4} = 2000 \text{ N}$$

- (ii) The body is moving in a circle so the unbalanced force = centripetal force

$$R = \frac{mv^2}{r}$$

$$v = \sqrt{\frac{Rr}{m}} = \sqrt{\frac{2000 \times 6}{80}} = 12 \text{ m s}^{-1}$$

- 3 (a) Gravitational potential is the amount of work done per unit mass in taking a small test mass from infinity (a place of zero potential) to the point in question.

- (b) (i) If field strength = 0 then field strength of planet is equal and opposite to field strength of moon.

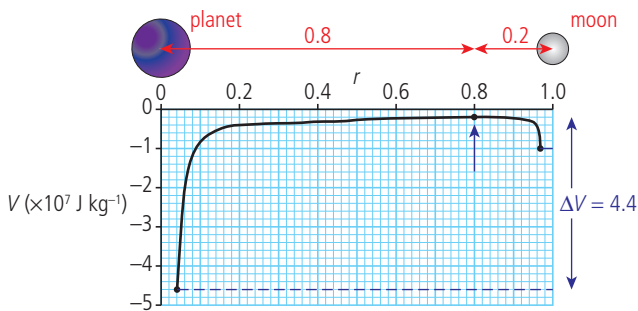

Note: field strength = 0 when gradient = 0

$$\frac{GM_p}{r_p^2} = \frac{GM_m}{r_m^2} \Rightarrow \frac{M_p}{M_m} = \frac{r_p^2}{r_m^2} = \frac{0.8^2}{0.2^2} = 16$$

- (ii) As satellite travels from planet its KE → PE

To reach the moon it must have enough KE so that it reaches the position of zero field, a distance $r = 0.8$ from the planet. From here to the moon it will be attracted by the moon's field

Loss of KE = gain in PE

$$\text{If final KE} = 0 \text{ then loss} = \frac{1}{2}mv^2$$

Gain in PE = change from planet to 0.8 from planet from the graph

$$\Delta V = 4.4 \times 10^7$$

$$\text{so } \Delta \text{PE} = 4.4 \times 10^7 \times 1500$$

$$= 6.6 \times 10^{10} \text{ J}$$

$$\text{Original KE} = 6.6 \times 10^{10} \text{ J}$$

4

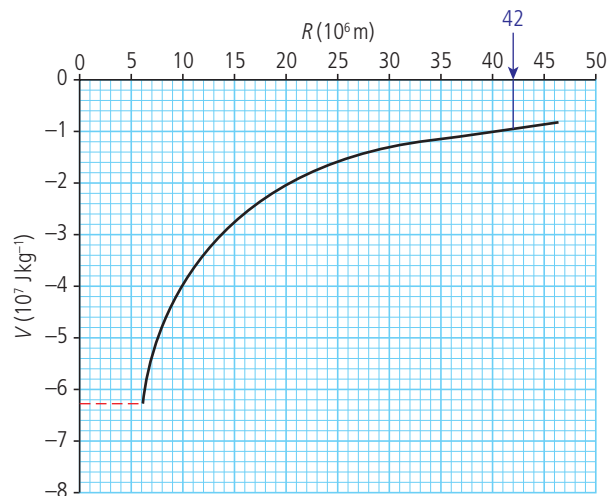

- (a) (i) V at surface = $-6.3 \times 10^7 \text{ J kg}^{-1}$

- (ii) Height $3.6 \times 10^7 \text{ m} = 36 \times 10^6 \text{ m}$

$$\text{So } R = (36 + 6) \times 10^6 \text{ m}$$

$$R = 42 \times 10^6 \text{ m}$$

$$\text{So from graph } V = -1.0 \times 10^7 \text{ J kg}^{-1}$$

- (b) As satellite leaves the Earth, KE → PE so if final KE = 0 then original KE = gain in PE

$$\text{From the graph } \Delta V = (6.3 - 1) \times 10^7 \text{ J kg}^{-1}$$

$$= 5.3 \times 10^7 \text{ J kg}^{-1}$$

$$\text{so } \Delta \text{PE} = 1 \times 10^4 \times 5.3 \times 10^7 = 5.3 \times 10^{11} \text{ J}$$

$$\text{So minimum KE} = 5.3 \times 10^{11} \text{ J}$$

- (c) The rocket doesn't stop when it reaches the orbit; it must have enough velocity to stay in orbit

$$\frac{mv^2}{r} = \frac{GM_m}{r^2}$$

During the early stages, whilst the rocket is in the atmosphere, energy is lost due to air resistance.

- 5 (a) The force is directed towards the centre so is perpendicular to the direction of motion. Work done is the force \times distance moved in the direction of the motion which is zero since there is no motion towards the centre. Alternatively one could argue that since the speed and distance to centre are constant there is no change in either KE or PE therefore no exchange of energy so no work done.

- (b) (i) The centripetal force is provided by gravitational attraction between the masses so

$$\frac{mv^2}{r} = \frac{GMm}{r^2}$$

$$v = \sqrt{\frac{Gm}{r}}$$

- (ii) Total energy = KE + PE

$$KE = \frac{1}{2}mv^2 = \frac{1}{2}m \frac{GM}{r} = \frac{GMm}{2r}$$

$$PE = \frac{-GMm}{r}$$

$$\text{Total energy} = \frac{GMm}{2r} - \frac{GMm}{r} = \frac{-GMm}{2r}$$

- (c) The total energy is $\frac{-GMm}{2r}$ so if r is increased total energy becomes less negative i.e. bigger. If the energy has increased then work has been done. To do this the engines must be fired in the direction of motion so rocket moves in the direction of the force.

- 6 (a) (i)

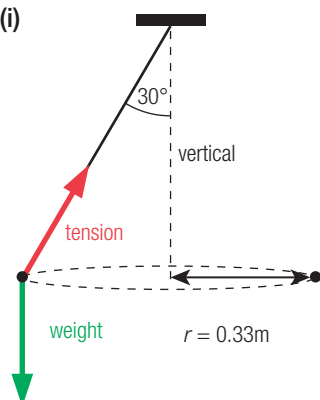

- (ii) The ball is not in equilibrium since it is not at rest or travelling at constant velocity. The forces are therefore not balanced as can be shown by adding together the forces on the diagram.

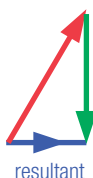

- (b) Mass is travelling in a circle so centripetal force = horizontal component of tension

$$\frac{mv^2}{r} = T \sin \theta$$

Since no vertical acceleration weight = vertical component of tension

$$mg = T \cos \theta$$

$$\text{Dividing gives } \tan \theta = \frac{v^2}{gr}$$

$$v = \sqrt{gr \times \tan \theta} = \sqrt{9.8 \times 0.33 \times \tan 30^\circ} = 1.4 \text{ ms}^{-1}$$

Challenge yourself

1 On the flat track

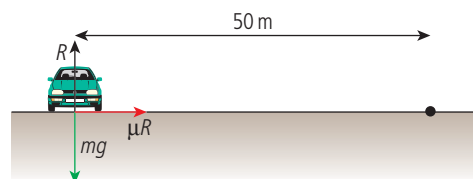

$$R = mg \text{ so } R = 10000 \text{ N}$$

$$\mu R = 0.8 \times 10000 = 8000 \text{ N}$$

$$\text{Circular motion so } \frac{mv^2}{r} = \mu R$$

$$v^2 = \frac{\mu R r}{m} = 8000 \times \frac{50}{1000} = 400$$

$$v = 20 \text{ ms}^{-1} = 72 \text{ km h}^{-1}$$

On a banked track

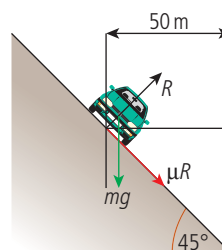

Notice the friction is acting down the slope since the force on the car is acting upwards.

Vertical components:

$$R \cos 45^\circ = mg + \mu R \sin 45^\circ$$

$$R = \frac{mg}{(\cos 45^\circ - \mu \sin 45^\circ)} = \frac{10000}{(\cos 45^\circ - 0.8 \sin 45^\circ)} = 7.1 \times 10^4 \text{ N}$$

Horizontal components:

$$\frac{mv^2}{r} = R \sin 45^\circ + \mu R \cos 45^\circ$$

$$v^2 = R(\sin 45^\circ + 0.8 \cos 45^\circ) \times \frac{r}{m}$$

$$v = 67 \text{ ms}^{-1} = 241 \text{ km h}^{-1}$$

Worked solutions

Chapter 5

Exercises

- 1 (a) acceleration is constant here so not simple harmonic motion

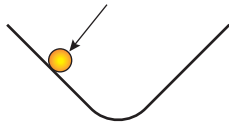

- (b)

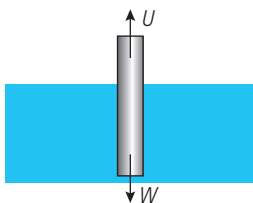

U is proportional to weight of fluid displaced; this is proportional to the distance the rod is pushed under the water so this is simple harmonic motion.

- (c) The tennis ball does not have an acceleration and displacement so this is not simple harmonic motion.
 (d) A bouncing ball has constant acceleration (g) except when bouncing so this is not simple harmonic motion.

- 2 (a) Frequency, $f =$ number of swings per second
 20 swings in 12 s (assuming complete swings)

$$\frac{20}{12} = 1.67 \text{ Hz}$$

- (b) Angular frequency, $\omega = 2\pi f = 10.49 \text{ rads/s}$

- 3

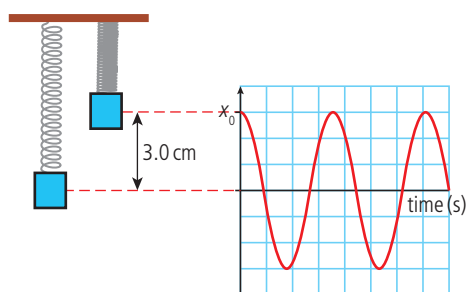

If released from the top then $x = x_0 \cos \omega t$

After 1.55 s

$$x = 3.0 \times \cos(2\pi \times 0.2 \times 1.55) = -1.1 \text{ cm}$$

- 4

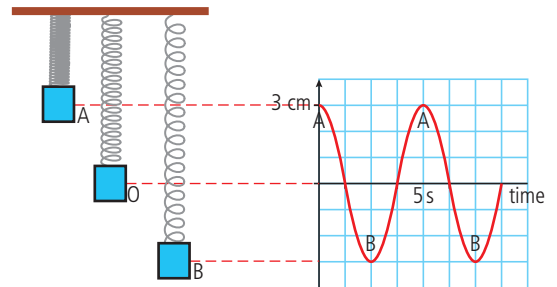

- 5 If time period = 10 s

$$\text{then } f = \frac{1}{10} = 0.1 \text{ Hz}$$

$$\text{So } \omega = 2\pi f = 0.1 \times 2\pi = 0.2\pi$$

Using the equation for simple harmonic motion

$$x = x_0 \cos \omega t$$

We want to know what the time is when $x = 1 \text{ m}$

$$1 = 2 \cos(0.2\pi t)$$

$$0.5 = \cos(0.2\pi t)$$

$$\text{So } \cos^{-1}(0.5) = 0.2\pi t = 1.047$$

$$t = \frac{1.047}{0.2\pi} = 1.67 \text{ s}$$

- 6

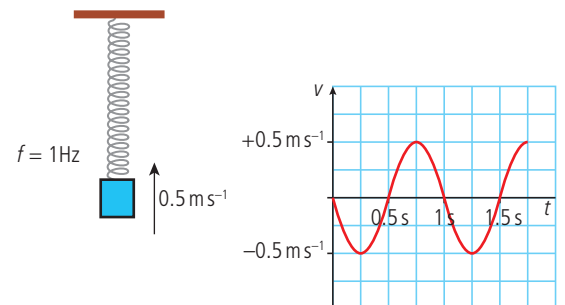

From the equation for simple harmonic motion

$$v = -v_0 \sin \omega t$$

$v_0 =$ the maximum velocity

We can see from the graph that 0.5 s after travelling upwards at 0.5 ms^{-1} , the mass will have a velocity of 0.5 ms^{-1} downwards.

7

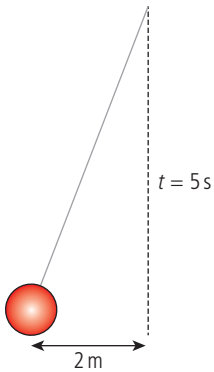

(a) Maximum velocity = ωx_0
 $= 2\pi f x_0$
 $= 2\pi \times \frac{1}{5} \times 2$
 $= 2.5 \text{ m s}^{-1}$

(b) Maximum acceleration = $\omega^2 x_0$
 $= \left(\frac{2\pi}{5}\right)^2 \times 2$
 $= 3.16 \text{ m s}^{-2}$

8

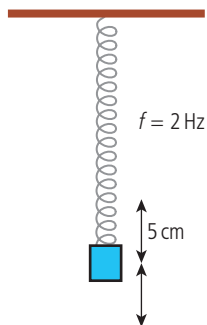

Using the equation
 $v = \omega \sqrt{x_0^2 - x^2}$
 $= 2\pi \times 2 \sqrt{0.05^2 - 0.01^2}$
 $= 4\pi \sqrt{0.0024}$
 $= 0.62 \text{ m s}^{-1}$

9 As it passes through the equilibrium position its velocity is maximum so use

$$v_{\max} = \omega x_0$$

$$= 2\pi \times \frac{1}{2} \times x_0 = 1 \text{ m s}^{-1}$$

$$x_0 = \frac{2}{2\pi} = \frac{1}{\pi} = 0.32 \text{ m}$$

10 $m = 0.1 \text{ kg}$
 $x_0 = 0.04 \text{ m}$
 $f = 1.5 \text{ Hz}$

(a) $\omega = 2\pi f = 3\pi \text{ rad s}^{-1}$

(b) maximum KE = $\frac{1}{2} m \omega^2 x_0^2$
 $= \frac{1}{2} \times 0.1 \times (3\pi)^2 \times 0.04^2$
 $= 7.1 \times 10^{-3} \text{ J}$

(c) maximum PE = maximum KE = $7.1 \times 10^{-3} \text{ J}$

(d) KE = $\frac{1}{2} m \omega^2 (x_0^2 - x^2)$
 $= \frac{1}{2} \times 0.1 \times (3\pi)^2 (0.04^2 - 0.02^2)$
 $= 5.3 \times 10^{-3} \text{ J}$

(e) At any given instant, PE + KE = $7.1 \times 10^{-3} \text{ J}$
 so PE = $7.1 \times 10^{-3} - 5.3 \times 10^{-3} \text{ J}$
 $= 1.8 \times 10^{-3} \text{ J}$

11 $f = \frac{1}{T} = \frac{1}{(30 \times 60)} = 5.6 \times 10^{-4} \text{ Hz}$
 $v = f\lambda = 5.6 \times 10^{-4} \times 500 \times 10^3 = 280 \text{ m s}^{-1}$

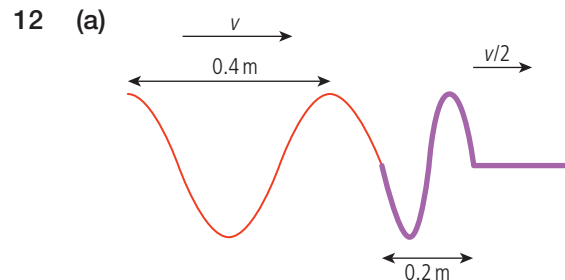

$v = f\lambda$ so λ is proportional to v

$$\frac{\lambda_1}{\lambda_2} = \frac{v_1}{v_2} = 2 \text{ so } \lambda_2 = \frac{\lambda_1}{2} = \frac{0.4}{2} = 0.2 \text{ m}$$

(b) Inverted since after knot medium is more dense

(c) Because some of the energy is in the reflected wave

13 $v = f\lambda$
 $f = \frac{1}{0.5} = 2 \text{ Hz}$
 $\lambda = 0.6 \text{ m}$
 $v = 2 \times 0.6 = 1.2 \text{ m s}^{-1}$

14 (a) $M = 1.2 \times 10^{-3} \text{ kg m}^{-1}$ $T = 40 \text{ N}$
 $V = \sqrt{\frac{T}{M}} = \sqrt{\frac{40}{1.2 \times 10^{-3}}} = 182.6 \text{ m s}^{-1}$

(b) $L = 63.5 \text{ cm}$
 $\lambda = 2L = 127 \text{ cm} = 1.27 \text{ m}$
 $V = f\lambda \Rightarrow f = \frac{V}{\lambda} = \frac{182.6}{1.27} = 143.8 \text{ Hz}$

15 $v = f \sqrt{\frac{T}{\mu}} = \frac{1}{2l} \sqrt{\frac{T}{\mu}}$
 $\lambda = 2l$
 $\mu = 1.2 \times \frac{10^{-3}}{2} = 0.6 \times 10^{-3} \text{ kg m}^{-1}$
 $T = f^2 \times 4l^2 \times \mu = 500^2 \times 4 \times 0.3^2 \times 0.6 \times 10^{-3}$
 $= 54 \text{ N}$

16

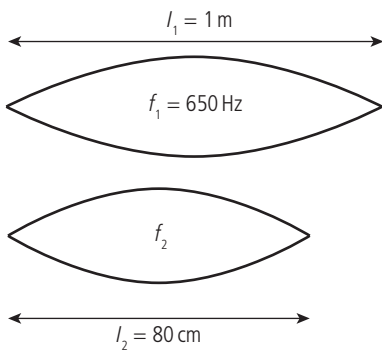

$$v = \sqrt{\frac{T}{\mu}}$$

T and μ are constant so f is proportional to $\frac{1}{l}$

$$\frac{f_1}{f_2} = \frac{l_1}{l_2} \frac{650}{f_2} = \frac{80}{100}$$

$$f_2 = 812.5 \text{ Hz}$$

17

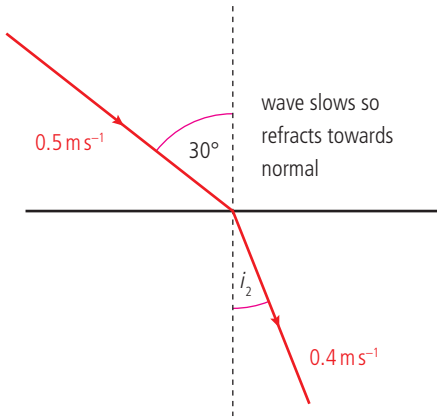

(a) $f = \frac{v}{\lambda} = \frac{0.5}{0.3} = 1.7 \text{ Hz}$

(b) $\lambda = \frac{v}{f} = \frac{0.4}{1.7} = 0.24 \text{ m}$

(c) $\frac{\sin i_1}{\sin i_2} = \frac{v_1}{v_2}$
 $\frac{\sin 30^\circ}{\sin i_1} = \frac{0.5}{0.4}$
 $\sin i_1 = \sin 30^\circ \times \frac{0.4}{0.5} = 0.4$
 $i_1 = 24^\circ$

18

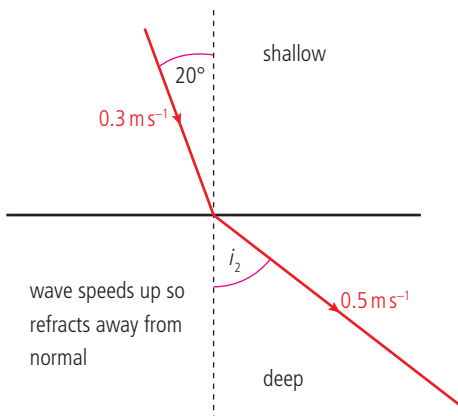

$$\frac{\sin i_1}{\sin i_2} = \frac{v_1}{v_2} = \frac{0.3}{0.5}$$

$$\sin i_2 = \sin 20^\circ \times \frac{0.5}{0.3}$$

$$i_2 = 35^\circ$$

19

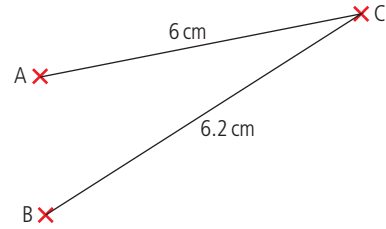

(a) $\lambda = 2 \text{ cm}$

path difference = $6.2 - 6 = 0.2 \text{ cm}$

phase angle = $\frac{\text{path difference}}{\lambda} \times 2\pi = \frac{0.2}{2.0}$

$$= \frac{1}{10} \times 2\pi = \frac{\pi}{5}$$

(b) $\frac{\text{path difference}}{\lambda} \times 2\pi = \frac{8-7}{2} = \frac{1}{2} \times 2\pi = \pi$

(c) $\frac{\text{path difference}}{\lambda} \times 2\pi = \frac{11.5-10}{2}$

$$= \frac{1.5}{2} \times 2\pi = \frac{3}{2}\pi$$

These answers are incorrect in some editions.

20

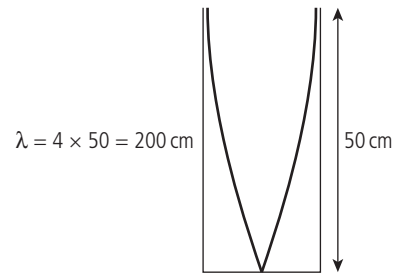

$$v = f\lambda$$

$$f = \frac{v}{\lambda} = \frac{340}{2} = 170 \text{ Hz}$$

21

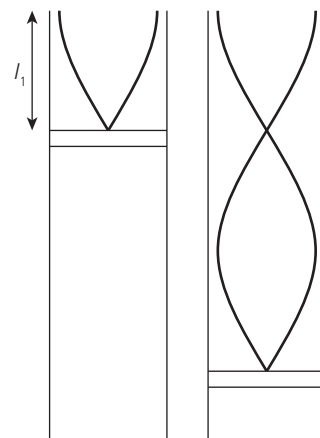

(a) First harmonic when $l_1 = \frac{1}{4}\lambda$

$$\lambda = \frac{v}{f} = \frac{340}{256} = 1.328 \text{ m}$$

$$l_1 = 33.2 \text{ cm}$$

- (b) Second harmonic when $l_2 = \frac{3}{4}\lambda = 99.6 \text{ cm}$
 Third harmonic when $l_3 = \frac{5}{4}\lambda = 166.0 \text{ cm}$
The third harmonic won't be heard.

22

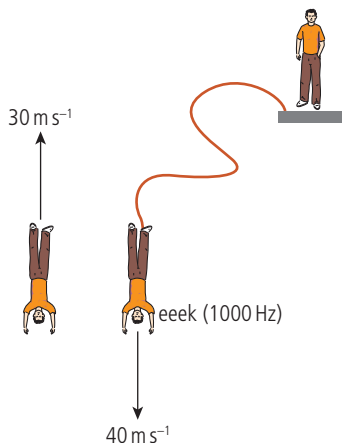

- (a) Would hear lower note on the way down and higher note on the way up.

- (b) Maximum on the way up

$$f_1 = \frac{cf_0}{c-v} = \frac{340 \times 1000}{340-30} = 1097 \text{ Hz}$$

- (c) Minimum on the way down

$$f_2 = \frac{cf_0}{c+v} = \frac{330 \times 1000}{330+40} = 895 \text{ Hz}$$

- (d) Would hear higher note on the way down and lower note on the way up.

23

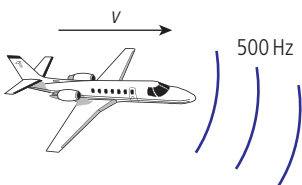

Frequency increases when plane approaches

$$f_1 = \frac{c \times f_0}{c-v}$$

$$\text{If frequency received} = 20000 \text{ Hz} = \frac{340 \times 500}{340-v}$$

$$340-v = \frac{340 \times 500}{20000} = 8.5; v = 340 - 8.5$$

$$v = 331.5 \text{ ms}^{-1}$$

24

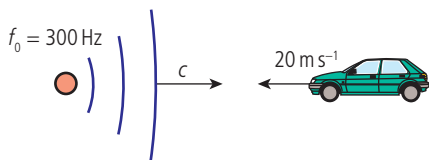

If moving towards source

$$f_1 = \frac{c+v}{c} \times f_0 = \frac{340+20}{340} \times 300$$

$$f_1 = 317.6 \text{ Hz}$$

25

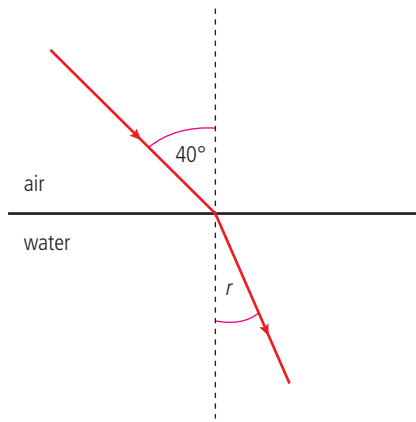

Using Snell's law $\frac{\sin i}{\sin r} = \text{refractive index}$

$$\frac{\sin 40^\circ}{\sin r} = 1.33 \text{ (from table)}$$

$$\sin r = \frac{\sin 40^\circ}{1.33} = 0.48$$

$$r = 29^\circ$$

Remember to change your calculator to degrees.

26

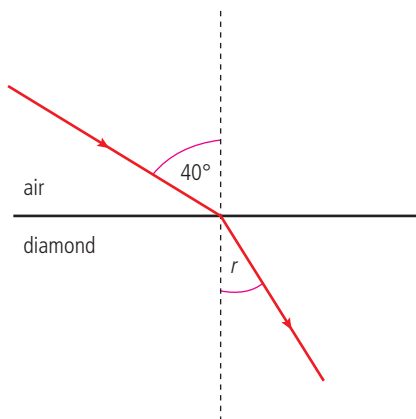

Using Snell's law $\frac{\sin i}{\sin r} = \text{refractive index}$

$$\frac{\sin 40^\circ}{\sin r} = 2.42$$

$$\sin r = \frac{\sin 40^\circ}{2.42} = 0.266$$

$$r = 15^\circ$$

27

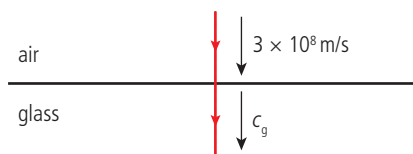

Refractive index when light travels from medium 1 → medium 2

$$= \frac{\text{velocity in medium 1}}{\text{velocity in medium 2}}$$

$$1.50 = \frac{3 \times 10^8}{c_g}$$

$$c_g = \frac{3 \times 10^8}{1.5} = 2 \times 10^8 \text{ ms}^{-1}$$

28

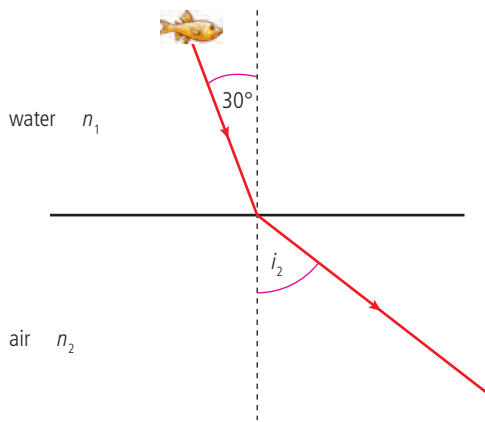

$$\frac{\sin i_1}{\sin i_2} = \frac{n_2}{n_1}$$

$$\frac{\sin 30^\circ}{\sin i_2} = 1.33$$

$$\sin i_2 = \sin 30^\circ \times 1.33$$

$$i_2 = 42^\circ$$

29

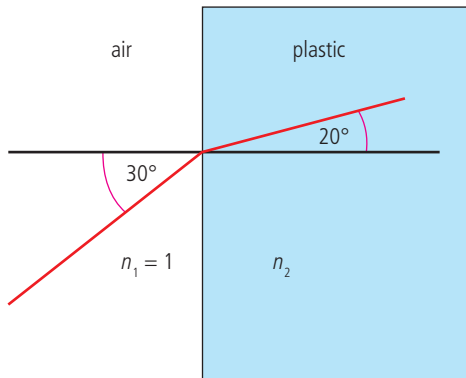

$$\frac{\sin i_1}{\sin i_2} = \frac{n_2}{n_1}$$

$$n_2 = 1 \times \frac{\sin 30^\circ}{\sin 20^\circ} = 1.46$$

Now surrounded by water:

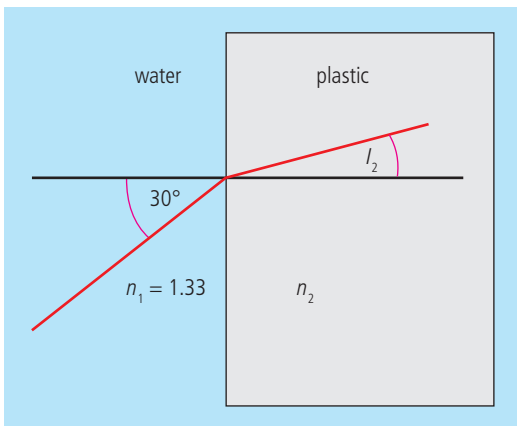

$$\frac{\sin i_1}{\sin i_2} = \frac{n_2}{n_1}$$

$$\sin i_2 = \sin 30^\circ \times \frac{1.33}{1.46} = 27^\circ$$

$$i_2 = 27^\circ$$

30

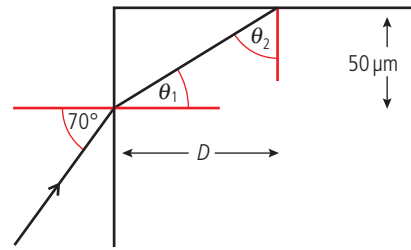

(a) $\frac{\sin 70^\circ}{\sin \theta_1} = 1.5$; $\sin \theta_1 = \frac{\sin 70^\circ}{1.5}$; $\theta_1 = 38.8^\circ$

(b) $\theta_2 + \theta_1 = 90^\circ$; $\theta_2 = 90 - 38.8 = 51.2^\circ$

(c) $\sin c = \frac{1}{n} \Rightarrow c = \sin^{-1}\left(\frac{1}{n}\right) = 41.8^\circ$

(d) Ray will be totally internally reflected

(e) $\tan 38.8 = \frac{50}{D}$; $D = 62.2 \mu\text{m}$

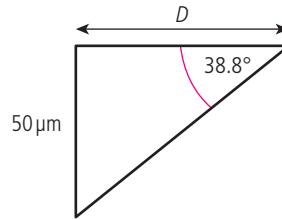

31

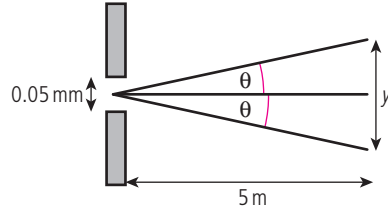

$$\lambda = 550 \text{ nm}$$

$$\theta = \frac{\lambda}{b} = \frac{550 \times 10^{-9}}{0.05 \times 10^{-3}} = 0.011 \text{ rad}$$

$$2\theta = \frac{y}{5} = 0.022 \Rightarrow y = 0.022 \times 5 = 0.11 \text{ m}$$

32

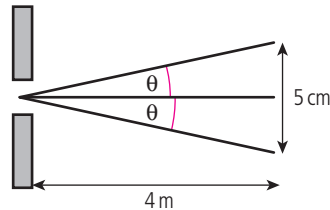

$$2\theta = \frac{0.05}{4} = 0.0125$$

$$\theta = 0.00625$$

$$\theta = \frac{\lambda}{b} \Rightarrow b \frac{\lambda}{\theta} = \frac{550 \times 10^{-9}}{0.00625}$$

$$b = 8.8 \times 10^{-5} \text{ m} = 88 \mu\text{m}$$

33

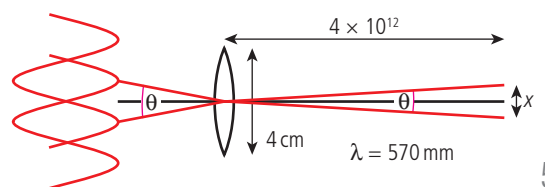

The angle θ between the two diffraction patterns can be found using

$$\theta = \frac{1.22\lambda}{b} = \frac{1.22 \times 570 \times 10^{-9}}{4 \times 10^{-2}} = 1.74 \times 10^{-5} \text{ rad}$$

The angle subtended by the stars $\theta = \frac{x}{4 \times 10^{12}}$
 $x = 1.74 \times 10^{-5} \times 4 \times 10^{12} = 7 \times 10^7 \text{ m}$

34

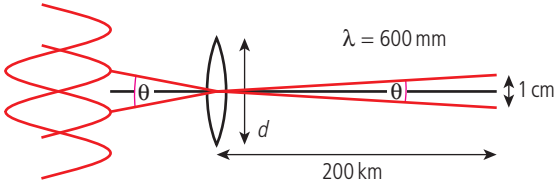

Angle subtended at camera

$$\theta = \frac{1 \times 10^{-2}}{200 \times 10^3} = 5 \times 10^{-8} \text{ rad}$$

$$\text{Diffracting angle } \theta = \frac{1.22\lambda}{b}$$

$$b = \frac{\lambda}{\theta}$$

$$= \frac{1.22 \times 600 \times 10^{-9}}{5 \times 10^{-8}} = 14.6 \text{ m}$$

35

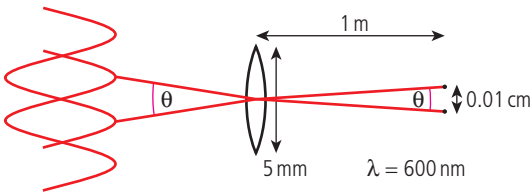

$$\text{Diffracting angle } \theta = \frac{1.22\lambda}{b} = \frac{1.22 \times 600 \times 10^{-9}}{5 \times 10^{-3}} = 1.5 \times 10^{-4} \text{ rad}$$

Angle subtended at eye by pixels,

$$\theta = \frac{0.01}{1} = 1 \times 10^{-4} \text{ rad}$$

The angle subtended is less than 1.5×10^{-4} so you will not be able to resolve them.

36

$$d = 0.01 \times 10^{-3} \text{ m}$$

$$\lambda = 600 \times 10^{-9} \text{ m}$$

$$D = 1.5 \text{ m}$$

$$b = \frac{\lambda D}{d} = \frac{600 \times 10^{-9} \times 1.5}{0.01 \times 10^{-3}} = 9 \text{ cm}$$

37

$$d = 0.01 \times 10^{-3} \text{ m}$$

$$\lambda = 400 \times 10^{-9} \text{ m}$$

$$D = 1.5 \text{ m}$$

$$b = \frac{\lambda D}{d} = \frac{400 \times 10^{-9} \times 1.5}{0.01 \times 10^{-3}} = 6 \text{ cm}$$

38

(a) 300 lines/mm

$$\text{separation of lines} = \frac{1}{300} = 3.3 \times 10^{-3} \text{ mm} = 3.3 \text{ } \mu\text{m}$$

(b) $d \sin \theta = n\lambda$, $n = 1$

$$\sin \theta = \frac{\lambda}{d} = \frac{700 \times 10^{-9}}{3.3 \times 10^{-6}} = 0.212$$

$$\theta = 12.24^\circ$$

39

$$\Delta\lambda = 589.6 - 589 = 0.6 \text{ nm}$$

$$R = \frac{\lambda}{\Delta\lambda} = mN; m = 1 \text{ (the order)}$$

$$N = \frac{589}{0.6} = 982 \text{ lines}$$

40

Constructive when $2t = (m + \frac{1}{2})\lambda$

minimum when $m = 0 \Rightarrow 2t = \frac{1}{2}\lambda$

$$t = \frac{1}{4}\lambda = \frac{1}{4} \times 600 \times 10^{-9} \text{ m} = 150 \text{ nm}$$

41

Destructive interference $t = \frac{\lambda}{4}$

$$t = \frac{380 \times 10^{-9}}{4} = 95 \text{ nm}$$

42

(a) Water has lower refractive index so no phase change.

Oil	$n = 1.5$
Water	$n = 1.3$

(b) $\lambda_{\text{oil}} = \frac{\lambda_{\text{air}}}{n} = \frac{580}{1.5} = 387 \text{ nm}$

(c) $2t = (m + \frac{1}{2})\lambda$ for constructive interference
 minimum when $m = 0$; $2t = \frac{1}{2}\lambda \Rightarrow t = \frac{1}{4}\lambda$
 $t = \frac{1}{4} \times 387 = 97 \text{ nm}$

43

Since the change at both boundaries is from less dense \rightarrow more dense

\Rightarrow no phase change on reflection

$\Rightarrow t = \frac{\lambda}{4}$ for destructive interference.

$$\lambda_{\text{coating}} = \frac{580}{1.4} = 414 \text{ nm}; t = \frac{414}{4} = 104 \text{ nm}$$

44

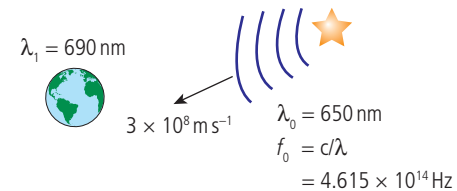

$$F_1 = \frac{c}{\lambda_1} = 4.348 \times 10^{14} \text{ Hz}$$

$$\Delta f = (4.615 - 4.348) \times 10^{14} = 2.67 \times 10^{13} \text{ Hz}$$

$$= \frac{v}{c} F_1 \Rightarrow v = \frac{c \times 2.67 \times 10^{13}}{4.348 \times 10^{14}} = 0.06c$$

45

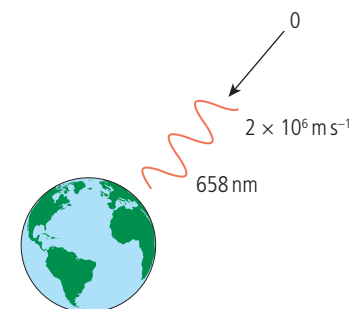

$$\Delta\lambda = \frac{v}{c}\lambda_0$$

$$\Delta\lambda = \frac{2 \times 10^6}{3 \times 10^8} \times 658 = 4.38 \text{ nm}$$

46

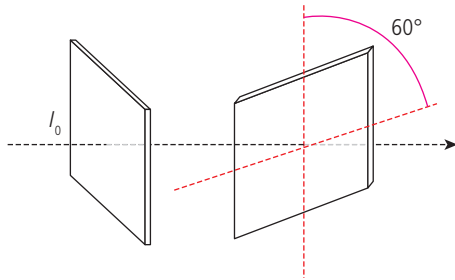

At first polarizer intensity transmitted
 = 50% of $I_0 = \frac{I_0}{2}$
 At second polarizer intensity transmitted
 = $I_0 \cos^2 \theta$
 but light incident on the second polarizer
 = $\frac{I_0}{2}$ so light transmitted = $\frac{1}{2} \times \cos^2 60^\circ$
 = $\frac{1}{2} \times \frac{1}{4} = \frac{I_0}{8}$

Practice questions

1

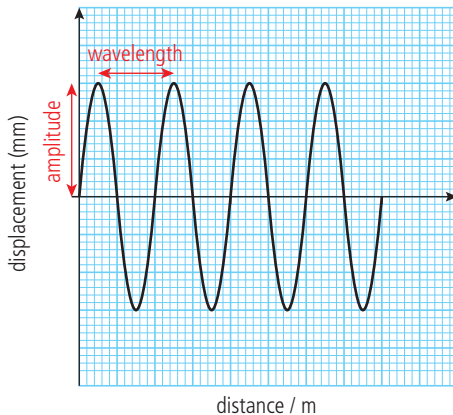

Note: the graph in some editions of the book is not the same as the original, which was much easier.

- (a) Sound is a longitudinal wave. You may be confused by the graph which looks transverse but remember this is a graph not the wave.
- (b) (i) Wavelength = 0.5 m
 (ii) Amplitude = 0.5 mm
 (iii) Speed = 330 ms⁻¹

- 2 (a) A ray shows the direction of a wave and a wavefront is a line joining points that are in phase. A ray is perpendicular to a wavefront.

- (b) (i) The line should be parallel to D.
 (ii) We can see that the wavelength gets shorter \Rightarrow velocity is less in medium R.

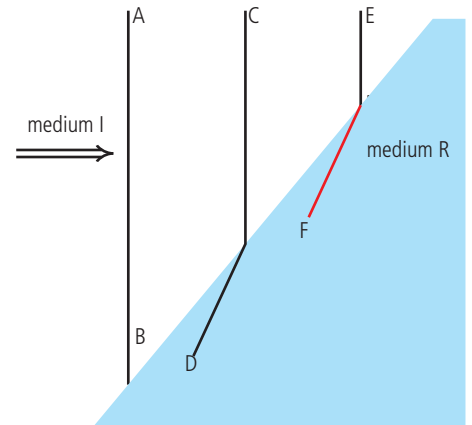

Could also tell from the way the wave bends.

$$\text{Ratio} = \frac{V_I}{V_R} = \frac{3.0}{1.5} = 2.0$$

- (c) (i) The sign of velocity changes \Rightarrow direction changes \Rightarrow body is oscillating.

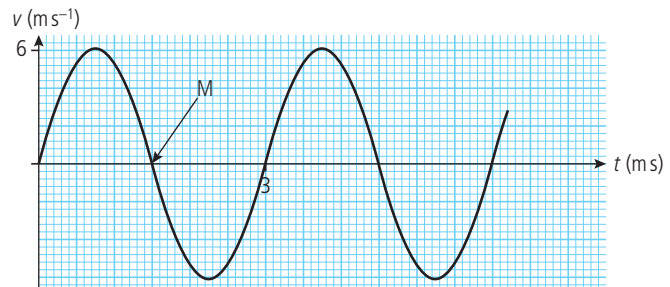

- (ii) Time period = 3 ms
 $F = \frac{1}{T} = \frac{1}{0.003} = 330 \text{ Hz}$
- (iii) Maximum displacement is when velocity is zero – think of a pendulum; it stops at the top.
- (iv) To find area either count squares or make a triangle that is a bit higher than the top.
 Squares are rather small so I prefer to calculate $\frac{1}{2} \times 7 \times 0.0015 = 5.25 \text{ mm}$

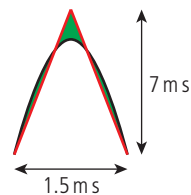

- (v) Area under $v-t$ graph is displacement.

In this case it is displacement between two times when velocity = zero i.e. $2 \times$ amplitude.

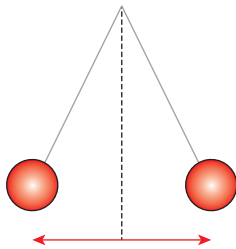

- 3 (a) (i) The speed of a wave is the distance travelled by the wave profile per unit time.

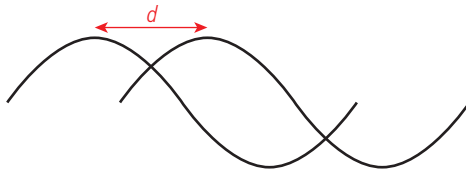

So if wave progressed distance d in time t , $v = \frac{d}{t}$

- (ii) Velocity = $\frac{\text{displacement}}{\text{time}}$ where displacement is the distance moved in a certain direction. However light spreads out in all directions.

- (b) (i) Displacement is how far a point on a wave is moved from its original position. For example on a water wave how far up or down a point is relative to the original flat surface of the water.

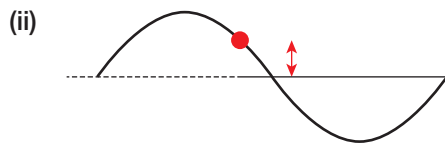

In a longitudinal wave, e.g. a wave in a slinky spring, the displacement is in the same direction as the wave but in a transverse wave, e.g. water, the displacement is perpendicular to the direction.

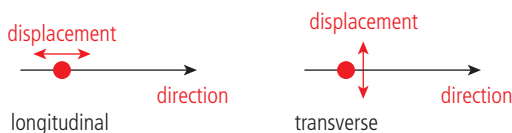

- (c) (i) From gradient $v_p = \frac{1200}{125} = 9.6 \text{ km s}^{-1}$
 (ii) $v_s = \frac{1200}{206} = 5.8 \text{ km s}^{-1}$



P wave is fastest so gets to the detector first.

- (ii) L_3 is closest because the signal arrives first.
 (iii) 1. First pulse arrives first.
 2. Separation of pulses is shorter.
 3. Amplitude of pulses is bigger.

- (iv) Measure on the graph where the horizontal distance between the lines is 68 s, 42 s and 27 s (approximately)

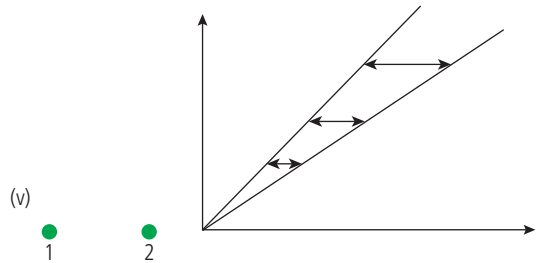

$\sim 1060 \text{ km}, 650 \text{ km}, 420 \text{ km}$
 $L_1 \quad L_2 \quad L_3$
 Closest to L_3 furthest from L_1

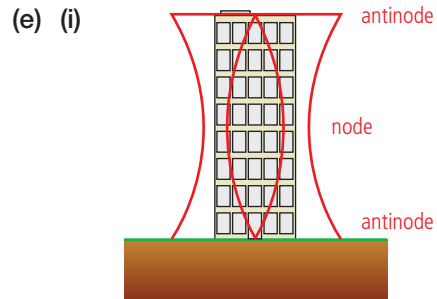

- (ii) If the standing wave is as shown then wavelength = $2 \times$ height of building
 $\lambda = 2 \times 280 = 560 \text{ m}$
 $v = f\lambda$ so $f = \frac{v}{\lambda} = \frac{3400}{560}$
 $= 6.1 \text{ Hz}$ (about 6 Hz)

So if the earthquake has a frequency of 6 Hz, the building will be forced to vibrate at its own natural frequency so will have a large amplitude vibration (resonance).

- 4 (a) Superposition is what happens when two waves coincide: the displacements of waves add vectorially to produce a resultant wave.

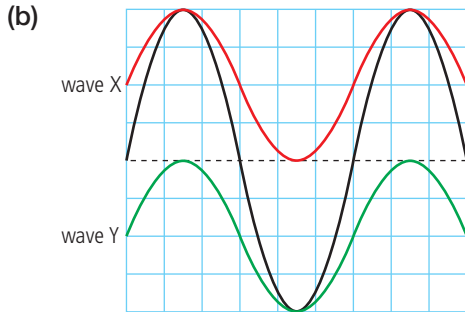

If X and Y are added they give the resultant.

- (c) (i) Two sources are said to be coherent if they have the same frequency, similar amplitude and a constant phase difference.
- (ii) To get interference the light from S_1 and S_2 must overlap; this only happens if the light is diffracted which means the slits must be narrow.
- (d) (i) For maximum intensity the path difference = $n\lambda$ where n is a whole number.

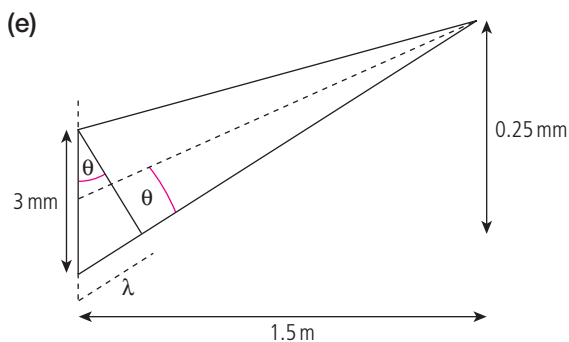
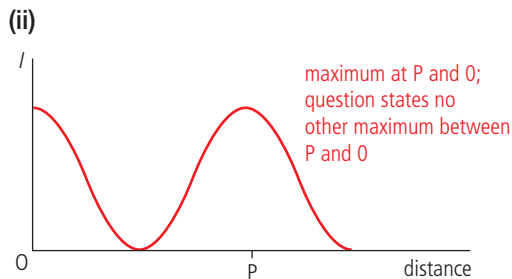

Since angle θ is

$$\theta = \frac{\lambda}{3} = \frac{0.25}{1500} \Rightarrow \lambda = \frac{3 \times 0.25}{1500} = 5 \times 10^{-4} \text{ mm} = 500 \mu\text{m}$$

Note: You probably don't need to do part e in the core; this is now only part of the EM option.

- 5 (a) (i)
-

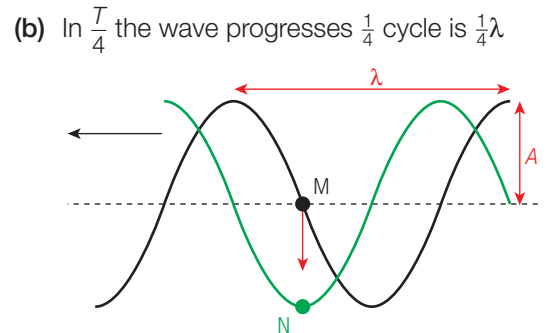

Wave moves left so trough is about to reach M.

- (c) (i) $\lambda = 5.0 \text{ cm}$; $v = 10 \text{ m s}^{-1}$
 $v = f\lambda \Rightarrow f = \frac{v}{\lambda} = \frac{10}{5} = 2.0 \text{ Hz}$
- (ii) In $\frac{1}{4}T$ wave moves $\frac{1}{4}\lambda = \frac{1}{4} \times 5.0 = 1.25 \text{ cm}$
- (d) When two waves coincide the resultant displacement at any point is equal to the vector sum of the individual displacements.

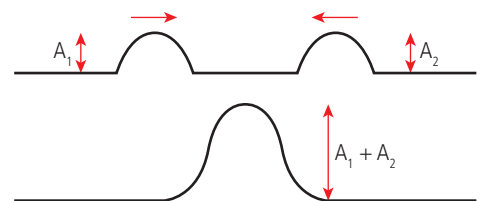

If waves that have the same frequency and a constant phase overlap then, due to superposition, they will add or cancel out. This is called interference.

- (e) (i) If the path difference = $n\lambda$ then there will be constructive interference. n is an integer.
- (ii) Since angles are small $\theta = \frac{S_2 X}{d}$

(iii) Again small angles so $\phi = \frac{y_n}{D}$

(f) (i) $\theta = 2.7 \times 10^{-3}$ rad
 $d = 1.4$ mm
 $\theta = \frac{S_2 X}{d}$ where $S_2 X = 8\lambda$
 so $\lambda = \frac{d\theta}{8} = \frac{1.4 \times 10^{-3} \times 2.7 \times 10^{-3}}{8}$
 $= 473$ nm

(ii) From geometry:
 $\phi = \theta = 2.7 \times 10^{-3}$ rad
 $D = 1.5$ m
 $\phi = \frac{y_n}{D} \Rightarrow y_n = \phi \times D = 4$ mm
 spacing $= \frac{4}{8} = 0.5$ mm

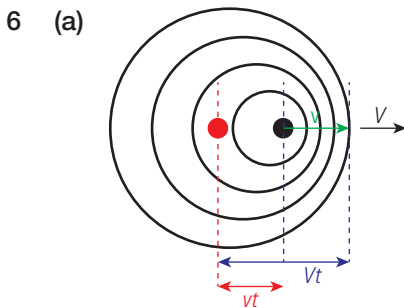

(b) In time t distance moved by source $= vt$
 distance moved by sound $= Vt$
 So all waves produced in time t are squashed into a distance $Vt - vt$ ahead of the source, so number of complete cycles produced $= f_0 t$

so $\lambda = \frac{Vt - vt}{f_0 t}$ but $f = \frac{V}{\lambda}$
 so apparent frequency $f_1 = \frac{V}{\lambda} = \frac{V \times f_0}{V - v}$

A bit confusing using V and v .

(c) Using the formula $\Delta\lambda = \frac{V}{c} \lambda$

$0.004 = \frac{V}{3 \times 10^8} \times 600$

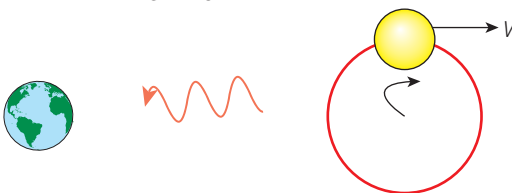

$V = \frac{0.004}{600} \times 3 \times 10^8 = 2 \times 10^3$ ms $^{-1}$
 $= 2$ kms $^{-1}$

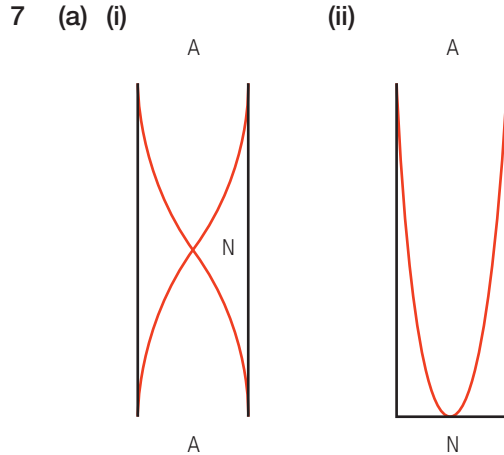

(b) (i) Frequency of 1st pipe $= 512$ Hz
 Wavelength of wave $= \frac{v}{f} = \frac{325}{512}$
 $= 63.5$ cm
 pipe is $\frac{1}{2}\lambda$ so length $= \frac{63.5}{2} = 31.7$ cm
 (ii) The length of a closed pipe is shorter than an open one of the same frequency so if the organ pipes are closed they take up less space.

8 (a) (i) When light passes through the aperture of the lens it will be diffracted (spread out).

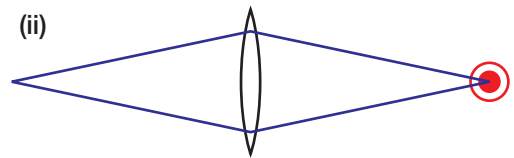

A circular opening leads to a circular diffraction pattern, as shown.

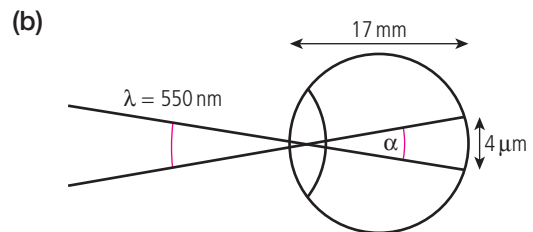

(i) angle is small so
 $\alpha = \frac{4 \times 10^{-6}}{17 \times 10^{-5}} = 2.4 \times 10^{-4}$ rad
 (ii) If $\alpha = \frac{1.22\lambda}{d}$ then resolved.
 So $d = \frac{1.22 \times 550 \times 10^{-9}}{2.4 \times 10^{-4}} = 2.8$ mm

Challenge yourself

1

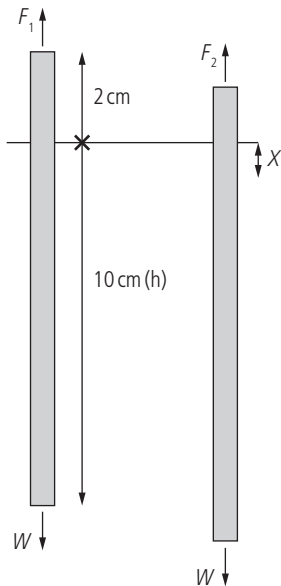

When floating the forces are balanced

$$F_1 = W$$

$$F_1 = \text{buoyant force} = \text{weight of fluid displaced} = hA\rho_w g$$

$$W = mg = hA\rho_w g$$

When pushed down there is extra buoyant force = $xA\rho_w g$

Resultant upward force = $-xA\rho_w g$ (if x taken to be in the positive direction this is -)

$$\text{acceleration} = \frac{-xA\rho_w g}{m}$$

but $m = hA\rho_w$ (from the condition of equilibrium)

$$a = \frac{-xA\rho_w g}{hA\rho_w}$$

$$a = -\left(\frac{g}{h}\right)x$$

This implies simple harmonic motion so

$$a = -\omega^2 x, \text{ so } \omega^2 = \frac{g}{h}$$

$$\omega = \frac{2\pi}{T} = \sqrt{\frac{g}{h}}$$

$$T = 2\pi\sqrt{\frac{h}{g}} = 0.6 \text{ s}$$

2 Equation of a wave = $A \sin\left(\omega t - \frac{2\pi x}{\lambda}\right)$

This wave travels from left to right, since points to the right of the origin lag behind the origin.

Equation of a wave travelling from right to left

$$= A \sin\left(\omega t + \frac{2\pi x}{\lambda}\right)$$

If these waves superpose the resultant displacement is given by

$$A \sin\left(\omega t - \frac{2\pi x}{\lambda}\right) + A \sin\left(\omega t + \frac{2\pi x}{\lambda}\right)$$

$$\text{But } \sin a + \sin b = 2 \sin\left(\frac{a+b}{2}\right) \cos\left(\frac{a-b}{2}\right)$$

$$\text{displacement} = 2A \sin\left(\left(\frac{\omega t}{2} - \frac{2\pi x}{2\lambda}\right) + \left(\frac{\omega t}{2} + \frac{2\pi x}{2\lambda}\right)\right)$$

$$\cos\left(\left(\frac{\omega t}{2} - \frac{2\pi x}{2\lambda}\right) - \left(\frac{\omega t}{2} + \frac{2\pi x}{2\lambda}\right)\right)$$

$$y = 2A \sin(\omega t) \cos\left(\frac{2\pi x}{\lambda}\right), \text{ since } \cos(-a) = \cos(a)$$

This displacement is zero when $\cos\left(\frac{2\pi x}{\lambda}\right) = 0$

which is when $\frac{2\pi x}{\lambda} = \frac{\pi}{2}, \frac{3\pi}{2}$ etc.

so when $x = \frac{\lambda}{4}, \frac{3\lambda}{4}$ etc.

These points are separated by $\frac{\lambda}{2}$.

Worked solutions

Chapter 6

Exercises

1 $E = 40 \text{ NC}^{-1}$
 $q = 5 \times 10^{-6} \text{ C}$
 $F = Eq = 40 \times 5 \times 10^{-6} = 2 \times 10^{-4} \text{ N}$

2 $F = 3 \times 10^{-5} \text{ N}$
 $q = -1.5 \times 10^{-6} \text{ C}$
 $E = \frac{F}{q} = \frac{3 \times 10^{-5}}{-1.5 \times 10^{-6}} = 20 \text{ NC}^{-1}$
 (direction is south, opposite to force since charge is negative)

3 $a = 100 \text{ ms}^{-2}$
 $q = -1.6 \times 10^{-19} \text{ C}$
 $m = 9.1 \times 10^{-31} \text{ kg}$
 $F = ma = 9.1 \times 10^{-29} \text{ N}$
 $E = \frac{F}{q} = 9.1 \times \frac{10^{-29}}{1.6 \times 10^{-19}} = 5.7 \times 10^{-10} \text{ NC}^{-1}$

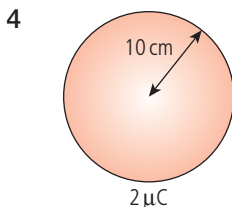

(a) Using the equation for electrical field strength of a sphere
 $E = \frac{kQ}{r^2}$
 $E = \frac{9 \times 10^9 \times 2 \times 10^{-6}}{(10 \times 10^{-2})^2} = 1.8 \times 10^6 \text{ NC}^{-1}$

(b) 10 cm from the sphere $r = 20 \text{ cm}$
 so $E = \frac{9 \times 10^9 \times 2 \times 10^{-6}}{(20 \times 10^{-2})^2}$
 $E = 4.5 \times 10^5 \text{ NC}^{-1}$

(c) Using the equation $E = \frac{F}{q} \Rightarrow F = Eq$
 So $F = 0.1 \times 10^{-6} \times 4.5 \times 10^5$
 $= 4.5 \times 10^{-2} \text{ N}$

(d) Relative permittivity $= \frac{\epsilon}{\epsilon_0} = 4.5$ so $\epsilon = 4.5\epsilon_0$
 F is proportional to $\frac{1}{\epsilon}$
 If sphere is surrounded by concrete
 $F = \frac{F_{\text{air}}}{4.5} = \frac{0.045}{4.5} = 0.01 \text{ N}$

5

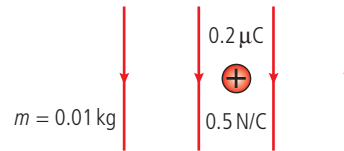

(a) From definition of E , $E = \frac{F}{q} \Rightarrow F = Eq$
 so $F = 0.5 \times 0.2 \mu\text{C} = 0.1 \mu\text{N}$

(b) From Newton's second law $F = ma$
 $a = \frac{F}{m} = \frac{0.1 \times 10^{-6}}{0.01} = 1 \times 10^{-5} \text{ ms}^{-2}$ in the direction of the field.

6

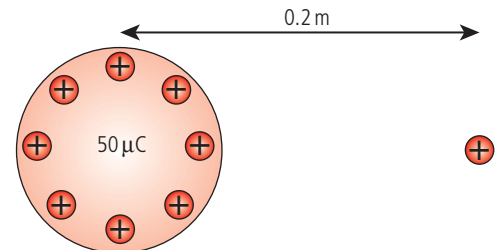

$$V = \frac{kQ}{r} = \frac{9 \times 10^9 \times 50 \times 10^{-6}}{0.2} = 2.25 \times 10^6 \text{ v}$$

7 0.4 m from the sphere $V = \frac{9 \times 10^9 \times 50 \times 10^{-6}}{0.4}$
 $= 1.13 \times 10^6 \text{ V}$
 potential difference $= (2.25 - 1.13) \times 10^6$
 $= 1.13 \times 10^6 \text{ V}$

8

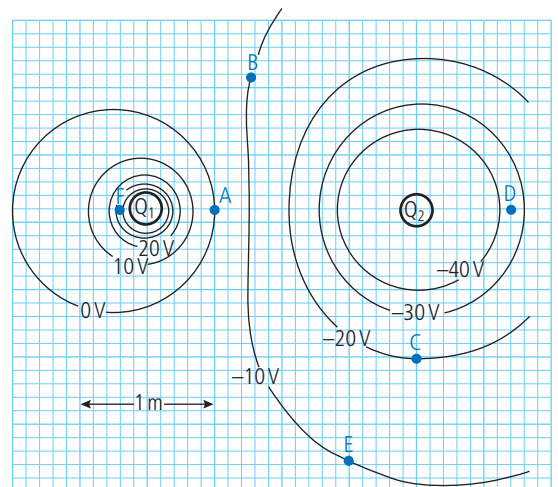

(a) Q_2 is negative since the potential near it is negative.

(b) A positive charge would move to a position of lower potential, i.e. towards Q_2

9 Field strength is greatest where the potential gradient is greatest (equipotential closest) so position F

- 10 (a) $A - C \rightarrow |0 - -20| = 20V$
 (b) $C - E \rightarrow |-20 - -10| = 10V$
 (c) $B - E \rightarrow |-10 - -10| = 0V$

- 11 (a) $C \rightarrow A$; $\Delta V = 20V$; work = $\Delta Vq = 20 \times 2 = 40J$
 (b) $E \rightarrow C$; $\Delta V = -10V$; work = $\Delta Vq = -10 \times 2 = -20J$
 (c) $B \rightarrow E$; $\Delta V = 0V$; work = $0J$

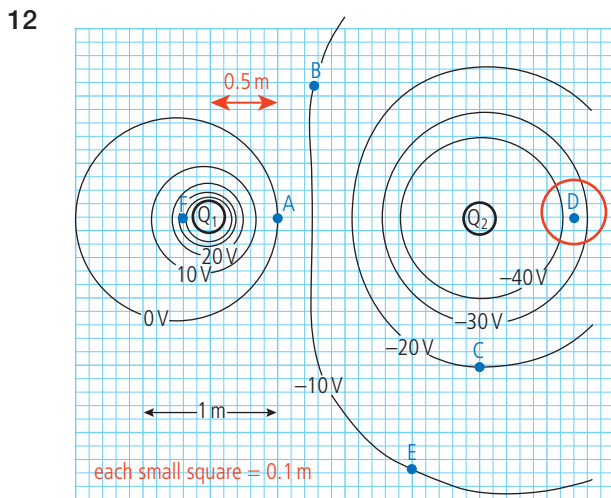

Field strength = $\frac{\Delta V}{\Delta x}$

The potential difference across D = 10V (using the two nearest lines)

Distance between lines = 0.2m

$E = \frac{10}{0.2} = 50Vm^{-1}$

Only an estimate since field not uniform

- 13 At point A potential = $0V = V_1 + V_2$
 $0 = \frac{kQ_1}{r_1} + \frac{kQ_2}{r_2} = 9 \times 10^9 \left(\frac{1 \times 10^{-9}}{0.5} + \frac{Q_2}{1.5} \right)$
 $Q_2 = \frac{-1.5}{0.5} \times 1 \times 10^{-9} = -3nC$

- 14 (a) $E \rightarrow A$; $\Delta V = 10V$; work done = $-10eV$
 (b) $C \rightarrow F$; $\Delta V = 50V$; work done = $-50eV$
 (c) $A \rightarrow C$; $\Delta V = -20V$; work done = $20eV$

- 15 $V_A = 1V$
 $V_C = 3V$
 potential difference = $2V$

- 16 $V_B = 5V$
 $V_D = 0V$
 potential difference = $5V$

- 17 $PE = V_0q = 5 \times 3 = 15J$

- 18 Change in potential from $C \rightarrow B = 5 - 3 = 2V$
 Work done = $\Delta V \times q = 2 \times 2 = 4J$

- 19 $V_{AB} = 5 - 1 = 4V$
 Work done = $\Delta V \times q = 4 \times -2 = -8J$

- 20 (a) It would accelerate downwards.
 (b) gain in KE = loss in PE = $\Delta V \times q = 4 \times 3 = 12J$

- 21 $V_{AB} = 5 - 1 = 4V$ gain in KE = $4eV$

- 22 $V_{CD} = 3 - 0 = 3V$ WD moving electron = $3eV$

- 23 (a) $\rho = \frac{M}{V}$ so $V = \frac{M}{\rho}$
 $\frac{0.0635}{8960} = 7.1 \times 10^{-6}m^3$
 (b) 1 mole contains 6×10^{23} molecules
 atoms per unit volume = $\frac{6 \times 10^{23}}{7.1 \times 10^{-6}}$
 $= 8.5 \times 10^{28}m^{-3}$
 one electron per atom so electrons per unit volume, $n = 8.5 \times 10^{28}m^{-3}$

- (c) $I = nAve \Rightarrow v = \frac{I}{nAe}$
 $A = \pi r^2$
 $v = \frac{1}{(8.5 \times 10^{28} \times \pi \times (0.5 \times 10^{-3})^2 \times 1.6 \times 10^{-19})}$
 $= 9.4 \times 10^{-5}ms^{-1}$

- 24 $R = \frac{\rho L}{A}$
 $A = \frac{\rho L}{R} = 1.1 \times 10^{-6} \times \frac{2}{5} = 4 \times 10^{-7}m^2$
 $A = \pi r^2$ $r = \sqrt{\frac{A}{\pi}} = 3.7 \times 10^{-4}m$
 So diameter = $3.7 \times 10^{-4}m$

- 25 $R = \frac{\rho L}{A} = 1.7 \times 10^{-8} \times \frac{2000}{\pi \times (0.1 \times 10^{-2})^2} = 10.8\Omega$

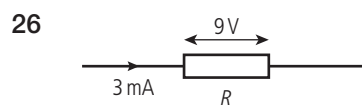

Using Ohm's law

$V = IR$
 $R = \frac{V}{I} = \frac{9}{3 \times 10^{-3}}$
 $= 3 \times 10^3 = 3k\Omega$

27

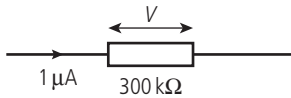

Using Ohm's law

$$V = IR$$

$$\begin{aligned} V &= 1 \times 10^{-6} \times 300 \times 10^3 \\ &= 300 \times 10^{-3} \\ &= 0.3V \end{aligned}$$

28

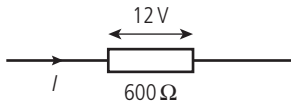

Using Ohm's law

$$V = IR$$

$$I = \frac{V}{R} = \frac{12}{600}$$

$$I = 0.02 = 20\text{mA}$$

29 Using Ohm's law

$$V = IR$$

$$R = \frac{V}{I}$$

V (V)	I (mA)	V/I kΩ
1.0	0.01	100
10.0	0.10	100
25.0	1.00	25

30

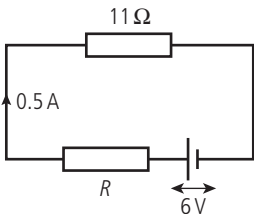

Using Ohm's law $V = IR$

$$\text{pd across } 11\ \Omega \text{ resistor} = 0.5 \times 11 = 5.5V$$

This means pd across $R = 0.5V$

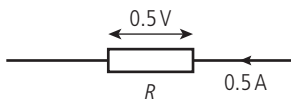

$$\text{Using Ohm's law again } R = \frac{V}{I} = 1\ \Omega$$

31

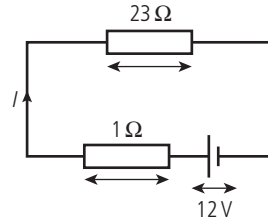

Total resistance in the circuit = $24\ \Omega$

Using Ohm's law $V = IR$

$$I = \frac{V}{R} = \frac{12}{24} = 0.5A$$

Using Ohm's law again the pd across the $23\ \Omega$ resistor = $IR = 0.5 \times 23 = 11.5V$

32

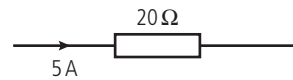

(a) Energy per second is power. Using the equation $P = I^2R$

$$P = 5^2 \times 20 = 25 \times 20$$

$$P = 500W$$

Therefore 500J is converted in 1 second.

(b) In 1 minute, $500 \times 60 = 3 \times 10^4$ J will be released.

33

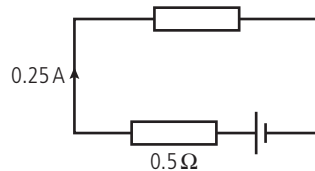

Using $P = I^2R$

The power dissipated in the internal resistance = $0.25^2 \times 0.5 = 0.031W$

34

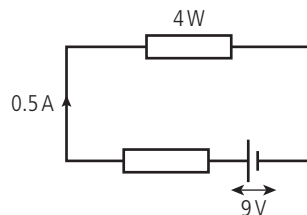

Power delivered by battery = IV

$$= 9 \times 0.5 = 4.5W$$

If 4W are dissipated in the external resistance 0.5W must be dissipated in the internal resistance.

35

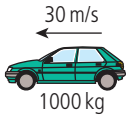

(a) $KE = \frac{1}{2}mv^2$
 $= \frac{1}{2} \times 1000 \times 30^2$
 $= 450 \text{ kJ}$

(b) Ignoring friction etc. the power of the car
 $= \frac{\text{energy gained}}{\text{energy taken}} = \frac{450000}{12} = 37.5 \text{ kW}$

(c) Using $P = IV$
 $37500 = I \times 300$
 $I = 125 \text{ A}$

36 No energy is lost, no heat produced, motor is 100% efficient, no friction

37

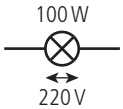

(a) Using $P = IV$
 $I = \frac{P}{V} = \frac{100}{220} = 0.45 \text{ A}$

(b) If 20% of 100W is converted to light,
 $\frac{20}{100} \times 100 = 20 \text{ W}$ are converted.
 That's 20J per second.

38 (a) Using $P = IV$

$$I = \frac{P}{V} = \frac{1000}{220} = 4.5 \text{ A}$$

(b) If the power is 1 kW then the heater releases 1000J per second. In 5 hours,
 $5 \times 60 \times 60 \times 1000 = 1.8 \times 10^7 \text{ J}$ are released.

39

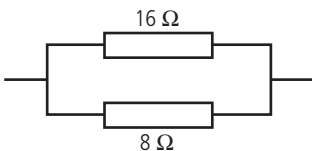

These resistors are in parallel so: $\frac{1}{R_T} = \frac{1}{R_1} + \frac{1}{R_2}$

$$= \frac{1}{16} + \frac{1}{8} = \frac{1}{16} + \frac{2}{16}$$

$$\frac{1}{R_T} = \frac{3}{16}$$

$$R_T = \frac{16}{3} \Omega$$

40

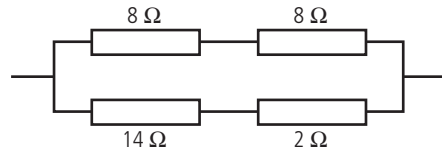

The top two and the bottom two are in series so they simply add.

This circuit can then be simplified:

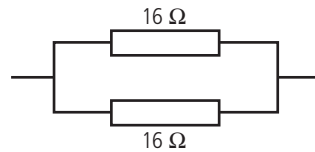

Two equal resistors in parallel have a combined resistance of $\frac{1}{2}$ of one of them so:

$$R_{\text{total}} = 8 \Omega$$

41

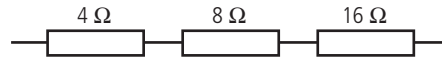

These are in series so the resistances simply add

$$R_T = 4 + 8 + 16 = 28 \Omega$$

42

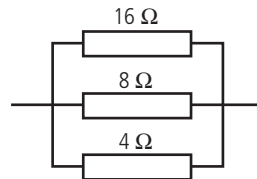

These 3 are in parallel so $\frac{1}{R_T} = \frac{1}{R_1} + \frac{1}{R_2} + \frac{1}{R_3}$
 $= \frac{1}{16} + \frac{1}{8} + \frac{1}{4}$

$$= \frac{1}{16} + \frac{2}{16} + \frac{4}{16} = \frac{7}{16}$$

$$R_T = \frac{16}{7} \Omega$$

43

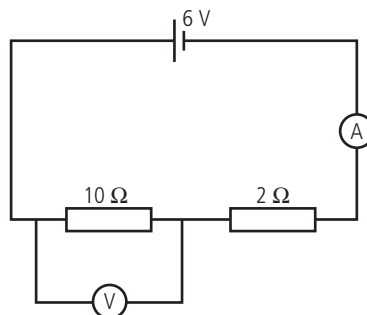

Total resistance = 12Ω

so using Ohm's law $I = \frac{V}{R} = \frac{6}{12} = 0.5 \text{ A}$

0.5A flows through the 10Ω resistor so

$$V = IR = 0.5 \times 10 = 5 \text{ V}$$

44

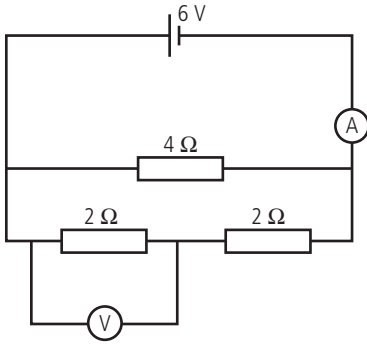

The two 2Ω resistors are in series so add up to give 4Ω . This combination is in parallel with the 4Ω resistor so the total resistance = 2Ω .

Using Ohm's law for the whole circuit

$$I = \frac{V}{R} = \frac{6}{2} = 3A$$

The pd across the two 2Ω resistors = $6V$. This will be dropped equally across them so pd across each = $3V$

45

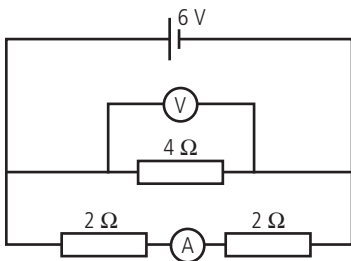

The pd across the 4Ω resistor is the same as the battery, $6V$.

The pd across the two 2Ω resistors is also $6V$.

They are in series so total resistance = 4Ω

Using Ohm's law $I = \frac{V}{R} = \frac{6}{4} = 1.5A$

46

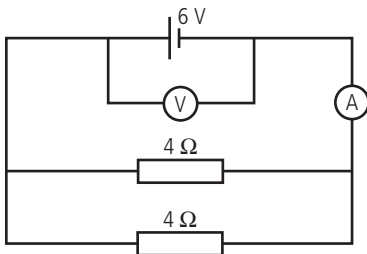

The voltmeter reads the pd across the battery = $6V$

The resistors are in parallel so total resistance = 2Ω

Using Ohm's law $I = \frac{V}{R} = \frac{6}{2} = 3A$

47

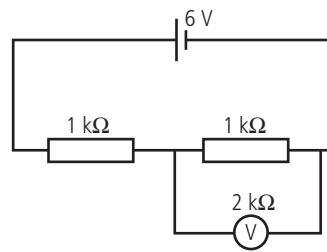

Without meter pd = $3V$

Resistance of $1k\Omega$ plus meter

$$\frac{1}{R} = \frac{1}{1} + \frac{1}{2} = \frac{3}{2} \Rightarrow R = \frac{2}{3} = 0.67k\Omega$$

Total resistance = $1.67k\Omega$

Current in whole circuit

$$I = \frac{V}{R_{\text{total}}} = \frac{6}{(R_1 + R_2)} = \frac{6}{1.67} \times 10^3 = 3.6mA$$

$$\text{pd across meter} = IR = 3.6 \times 10^{-3} \times 0.67 \times 10^3 = 2.4V$$

$$\text{Difference} = 3 - 2.4 = 0.6V$$

$$\% \text{ difference} = \left(\frac{0.6}{3}\right) \times 100\% = 20\%$$

48

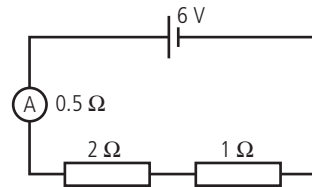

Without meter $R = 3\Omega$

$$I = \frac{V}{R} = \frac{6}{3} = 2A$$

With meter $R = 3.5\Omega$

$$I = \frac{6}{3.5} = 1.7A$$

$$\text{Difference} = 0.3A$$

$$\% \text{ difference} = \left(\frac{0.3}{2}\right) \times 100\% = 15\%$$

49

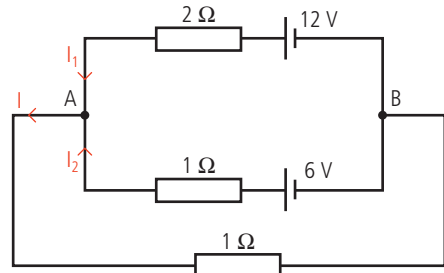

Kirchhoff's first law

$$I_1 + I_2 = I \quad (1)$$

Kirchhoff's second law to outer loop

$$12 = 2I_1 + I \quad (2)$$

Inner loop

$$6 = I_2 + I \quad (3)$$

Need to find I so substitute for I_2 in (3)

$$6 = (I - I_1) + I = 2I - I_1$$

multiply by 2; $12 = 4I - 2I_1$

add this to (2) ($12 = I + 2I_1$);

$$24 = 5I$$

$$I = 4.8 \text{ A}$$

$$\text{so } V_{AB} = 1 \times 4.8 = 4.8 \text{ V}$$

Check:

$$I_1 = \frac{(12 - I)}{2} = 3.6 \text{ A}$$

$$I_2 = 4.8 - 3.6 = 1.2 \text{ A}$$

Fill in all the unknowns to see if consistent:

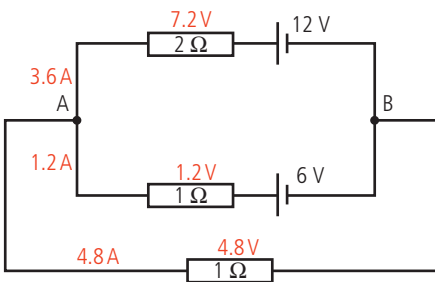

50

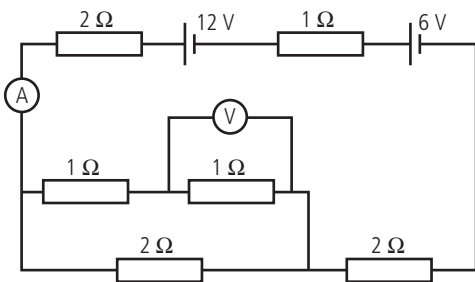

Assume meters are all ideal.

First find total resistance.

Total for parallel combination at the bottom left

$$\frac{1}{R} = \frac{1}{2} + \frac{1}{2} = 1, \text{ so } R = 1 \Omega$$

Add the series resistors R

$$R_{\text{total}} = 2 + 1 + 2 + 1 = 6 \Omega$$

Total emf = 18V

$$\text{Current} = \frac{18}{6} = 3 \text{ A}$$

Ammeter reading = 3A

pd across parallel combination = $1 \times 3 = 3 \text{ V}$

Current through top branch = $\frac{3}{2} \text{ A}$

pd across 1Ω resistor = $\frac{3}{2} \times 1 = 1.5 \text{ V}$

Voltmeter reading = 1.5V

Fill out the rest to make sure consistent:

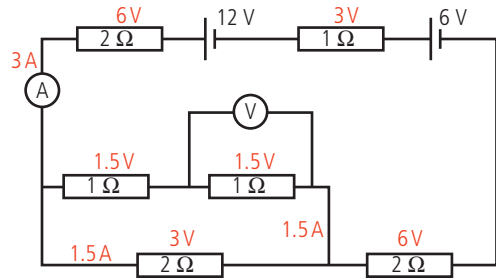

51

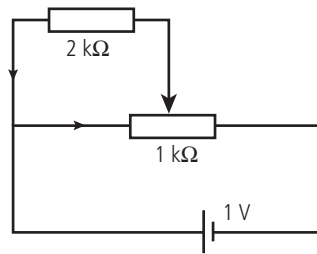

Total of parallel combination $\frac{1}{R} = \frac{1}{2} + \frac{1}{0.5} = 2.5$,
so $R = 0.4 \text{ k}\Omega$

$$R_{\text{total}} = 0.9 \text{ k}\Omega$$

$$\text{Current} = \frac{V}{R} = \frac{1}{900} = 1.11 \text{ mA}$$

$$\text{pd across } 0.4 \text{ k}\Omega = 1.11 \times 10^{-3} \times 0.4 \times 10^3 = 0.44 \text{ V}$$

Or

$$V_o = \frac{R_2}{R_1 + R_2} \times V_i = \frac{0.4}{0.9} \times 1 = 0.44 \text{ V}$$

52

$$\text{Resistance of nichrome} = \frac{\rho L}{A} = 1.5 \times 10^{-6} \times \frac{1}{\pi} \times (0.05 \times 10^{-3})^2 = 191 \Omega$$

Length divided by $\frac{3}{4}$ gives:

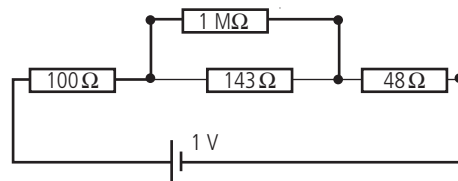

Ignore the $1 \text{ M}\Omega$ as it will draw hardly any current.

Total resistance = 291Ω

$$\text{current } I = \frac{V}{R} = \frac{1}{291} = 3.44 \text{ mA}$$

$$V_{143} = IR = 3.44 \times 10^{-3} \times 143 = 0.49 \text{ V}$$

53

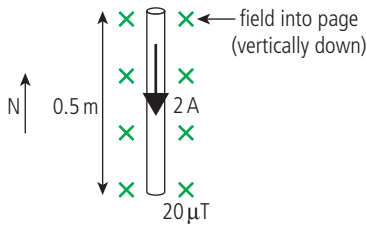

- (a) Using the formula $F = BIL$
 $F = 20 \times 10^{-6} \times 2 \times 0.5$
 $F = 2 \times 10^{-5} \text{ N}$

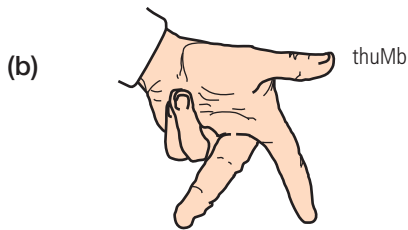

seCond (north-south) First (vertically downwards)

Using Fleming's left hand rule, force is to the east

54

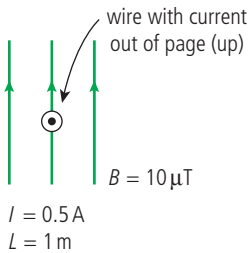

- (a) Using formula $F = BIL$
 $F = 10 \times 10^{-6} \times 0.5 \times 1 \text{ m}$
 $F = 5 \times 10^{-6} \text{ N}$

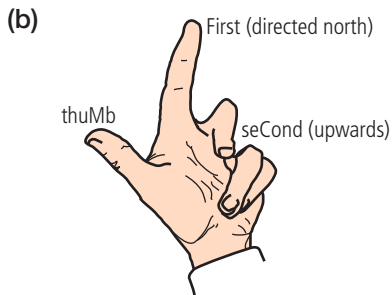

Using Fleming's left hand rule (probably best using your own ☺), force is west

55 Use Fleming's left hand rule:

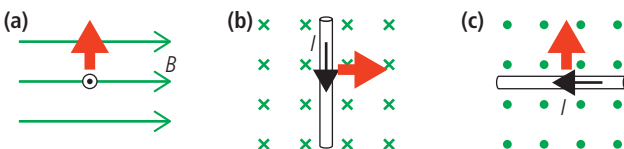

56 $F = Bqv = 5 \times 10^{-3} \times 1.6 \times 10^{-19} \times 500$
 $= 4 \times 10^{-19} \text{ N}$

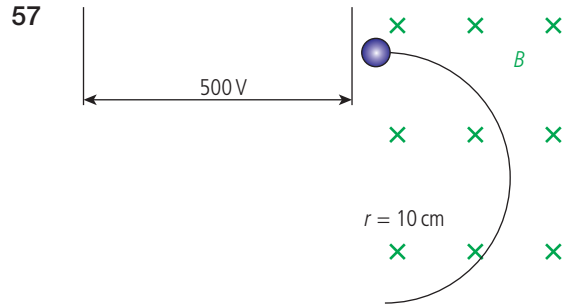

- (a) $\text{KE} = Vq = 500 \times 1.6 \times 10^{-19} = 8 \times 10^{-17} \text{ J}$
 (b) $\text{KE} = \frac{1}{2}mv^2$
 $v = \sqrt{\frac{2\text{KE}}{m}} = \sqrt{\frac{2 \times 8 \times 10^{-17}}{9.1 \times 10^{-31}}} = 1.3 \times 10^7 \text{ ms}^{-1}$
 (c) Moving in a circle so
 $Bqv = \frac{mv^2}{r}$
 $B = \frac{mv}{qr}$
 $= \frac{9.1 \times 10^{-31} \times 1.3 \times 10^7}{1.6 \times 10^{-19} \times 0.1}$
 $= 7.4 \times 10^{-4} \text{ T}$

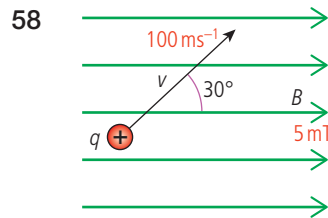

$F = Bqv \sin \theta$
 $= 5 \times 10^{-3} \times 1.6 \times 10^{-19} \times 100 \times \sin 30^\circ$
 $= 4 \times 10^{-20} \text{ N}$

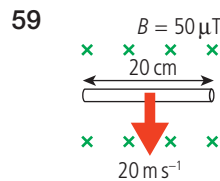

(a) $\text{emf} = BLv$
 $= 50 \times 10^{-6} \times 0.2 \times 20$
 $= 2 \times 10^{-4} \text{ V}$

(b) Using Ohm's law
 $I = \frac{V}{R} = \frac{2 \times 10^{-4}}{2}$
 $= 1 \times 10^{-4} \text{ A}$

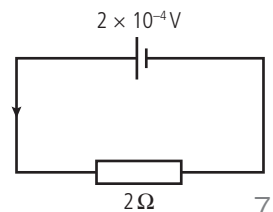

- (c) Power dissipated = $I^2R = (1 \times 10^{-4})^2 \times 2$
 $= 2 \times 10^{-8} \text{W(J/s)}$
- (d) Work done = energy dissipated = $2 \times 10^{-8} \text{J}$
- (e) Velocity of wire = 20 m s^{-1} so moves 20 m in 1 s.
- (f) Work done = $F \times d$
 $F = \frac{\text{work}}{\text{distance}} = \frac{2 \times 10^{-8}}{20} = 1 \times 10^{-9} \text{N}$
 (Since velocity is constant the forces are balanced.)

60

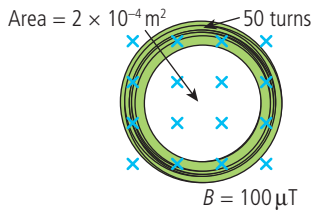

- (a) Flux enclosed by each coil = $A \times B$
 $= 2 \times 10^{-4} \times 100 \times 10^{-6} = 2 \times 10^{-8} \text{ Tm}^2$
 Since there are 50 turns, total flux
 $= 50 \times 2 \times 10^{-8} = 1 \times 10^{-6} \text{ Tm}^2$
- (b) If flux density changed to $50 \mu\text{T}$ then flux enclosed = $0.5 \times 10^{-6} \text{ Tm}^2$
 Rate of change of flux = $\frac{\Delta B}{\Delta t} = \frac{1.0 - 0.5}{2}$
 $= 0.25 \mu\text{Tm}^{-2} \text{ s}^{-1}$
- (c) Induced emf = rate of change of flux
 $= 0.25 \mu\text{V}$

61

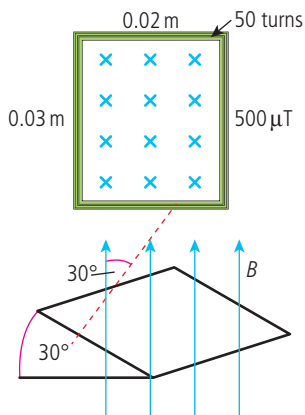

- (a) Flux enclosed = BAN
 $= 500 \times 10^{-6} \times 0.02 \times 0.03 \times 50$
 $= 1.5 \times 10^{-5} \text{ Tm}^2$

- (b) Component of field perpendicular to plane of coil = $B \cos 30^\circ$
 Flux enclosed = $BAN \cos 30^\circ$
 $= 1.3 \times 10^{-5} \text{ Tm}^2$
- (c) emf = rate of change of flux = $\frac{\Delta B}{\Delta t}$
 $= \frac{(1.5 - 1.3) \times 10^{-5}}{3} = 0.67 \mu\text{V}$

62 $I_{\text{rms}} = \frac{I_0}{\sqrt{2}} \Rightarrow I_0 = I_{\text{rms}} \times \sqrt{2}$

$I_0 = 110 \times \sqrt{2} = 156 \text{V}$

63 $V_{\text{rms}} = 220 \text{V}; P = V_{\text{rms}} I_{\text{rms}} = 4000 \text{W}$

$I_{\text{rms}} = \frac{4000}{220} = 18 \text{A}$

64

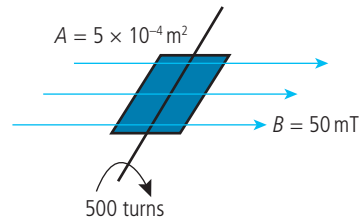

(a) (i) $50 \text{ rev s}^{-1} = 50 \times 2\pi \text{ rad s}^{-1}$
 $= 100\pi \text{ rad s}^{-1}$

(ii) $\epsilon_{\text{max}} = BAN\omega = 3.9 \text{V}$

(iii) $\epsilon_{\text{rms}} = \frac{3.9}{\sqrt{2}} = 2.8 \text{V}$

(b) $\frac{1}{2}$ the angular velocity so $\frac{1}{2}$ the $\epsilon_{\text{rms}} = 1.4 \text{V}$

65 $P = \frac{V_{\text{rms}}^2}{R} \Rightarrow R = \frac{V_{\text{rms}}^2}{P} = \frac{200^2}{1000} = 48.4 \Omega$

66 $V_p = 220 \text{V}$

$V_s = 4.5 \text{V}$

(a) If $N_p = 500$, $\frac{N_p}{N_s} = \frac{V_p}{V_s}$

$\frac{500}{N_s} = \frac{220}{4.5}$

$N_s = \frac{500 \times 4.5}{220} = 10.3 \text{ turns (10)}$

(b) $P = IV = 0.45 \times 4.5 = 2 \text{W}$

- (c) If 100% efficient
 power in = power out

$I_p V_p = I_s V_s$

$I_p \times 220 = 0.45 \times 4.5$

$I_p = 9.2 \text{mA}$

- (d) If charger not charging then no power out, which implies no power in, so no current flows.

This is for a 100% ideal transformer.

67

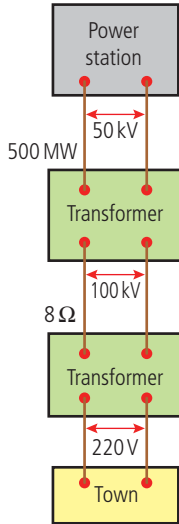

- (a) 500 MW at 100 kV; $P = VI$
 $I = \frac{P}{V} = \frac{500 \times 10^6}{100 \times 10^3} = 5 \times 10^3 \text{ A}$
- (b) Power loss = $I^2 R = (5 \times 10^3)^2 \times R = 200 \text{ MW}$
- (c) $\frac{200}{500} \times 100\% = 40\%$
- (d) Power delivered = $500 - 200 = 300 \text{ MW}$
- (e) Available to town = 300 MW
- (f) $P = VI$; $I = \frac{300 \times 10^6}{220} = 1.36 \text{ MA}$

68

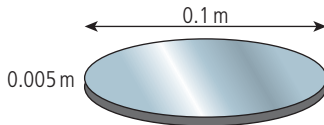

$$C = \frac{\epsilon_0 A}{d} = \frac{8.85 \times 10^{-12} \times \pi \times 0.05^2}{0.005} = 1.39 \times 10^{-11} \text{ F}$$

69

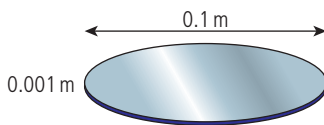

$$C = \frac{\epsilon_r \epsilon_0 A}{d} = \frac{4 \times 8.85 \times 10^{-12} \times \pi \times 0.05^2}{0.001} = 2.78 \times 10^{-10} \text{ F}$$

70

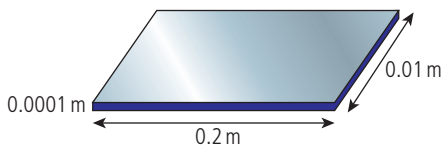

$$C = \frac{\epsilon_r \epsilon_0 A}{d} = \frac{5 \times 8.85 \times 10^{-12} \times 2 \times 0.01}{0.0001} = 8.85 \times 10^{-9} \text{ F}$$

- 71
- $Q = CV = 2 \times 10^{-6} \times 6 = 1.2 \times 10^{-5} \text{ C}$

- 72 (a) In series
- $\frac{1}{C} = \frac{1}{C_1} + \frac{1}{C_2} = \frac{1}{4} + \frac{1}{8} = \frac{3}{8}$
-
- $C = \frac{8}{3} = 2.67 \mu\text{F}$

- (b) In parallel
- $C = C_1 + C_2 = 12 \mu\text{F}$

73

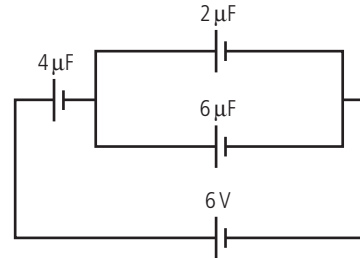

Capacitance of the capacitors in parallel is $2 + 6 = 8 \mu\text{F}$

$$\frac{1}{C} = \frac{1}{C_1} + \frac{1}{C_2} = \frac{1}{4} + \frac{1}{8} = \frac{3}{8}$$

$$C = \frac{8}{3} \mu\text{F}$$

$$\text{Total charge} = CV = \frac{8}{3} \times 6 = 16 \mu\text{C}$$

Charge on the $4 \mu\text{F}$ capacitor is equal to total charge so $V = \frac{Q}{C} = \frac{16}{4} = 4 \text{ V}$

74

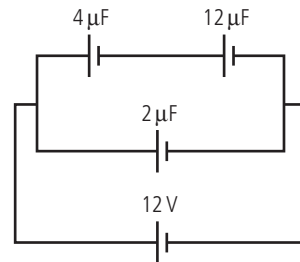

Total of the capacitors in series is $\frac{1}{C} = \frac{1}{C_1} + \frac{1}{C_2} = \frac{1}{4} + \frac{1}{12} = \frac{4}{12}$

$$C = 3 \mu\text{F}$$

Charge on the capacitors in series is

$$CV = 3 \times 12 = 36 \mu\text{C}$$

Charge on the $4 \mu\text{F}$ capacitor is the same as the total charge on the capacitors in series = $36 \mu\text{C}$

$$\text{pd across the } 4 \mu\text{F capacitor} = \frac{Q}{C} = \frac{36}{4} = 9 \text{ V}$$

- 75
- $E = \frac{1}{2} CV^2 = \frac{1}{2} \times 5 \times 10^{-6} \times 9^2 = 2.03 \times 10^{-4} \text{ J}$

- 76 (a)
- $C = \frac{\epsilon_0 A}{d} = 8.85 \times 10^{-12} \times \pi \times \frac{0.1^2}{0.002} = 1.39 \times 10^{-10} \text{ F}$

- (b)
- $Q = CV = 1.39 \times 10^{-10} \times 6 = 8.34 \times 10^{-10} \text{ C}$

- (c)
- $E = \frac{1}{2} QV = \frac{1}{2} \times 8.34 \times 10^{-10} \times 6 = 2.5 \times 10^{-9} \text{ J}$

- (d) If isolated, charge will remain the same but new capacitance is $\frac{1}{2}$ previous

$$C = 6.95 \times 10^{-11} \text{ F}$$

$$Q = 8.34 \times 10^{-10} \text{ C}$$

$$E = \frac{Q^2}{2C} = 5 \times 10^{-9} \text{ J}$$

Extra energy stored is gained from work done pulling plates apart.

- 77 50 electrons so $Q = 50 \times 1.6 \times 10^{-19} \text{ C}$
 $= 8 \times 10^{-18} \text{ C}$

$$V = \frac{Q}{C} = \frac{8 \times 10^{-18}}{100 \times 10^{-9}} = 8 \times 10^{-11} \text{ V}$$

- 78 (a) $\tau = CR = 5 \times 10^{-3} \times 10 \times 10^3 = 50 \text{ s}$
 (b) $Q = CV = 5 \times 10^{-3} \times 10 = 50 \text{ mC}$
 (c) When discharging $V = V_0 e^{-\frac{t}{RC}}$
 $V = 10 \times e^{-\frac{20}{50}} = 6.7 \text{ V}$
 (d) When starting to discharge pd across $R = 10 \text{ V}$

$$I = \frac{V}{R} = \frac{10}{10 \times 10^3} = 1 \text{ mA}$$

- (e) When discharging $I = I_0 e^{-\frac{t}{RC}}$

$$\ln\left(\frac{I}{I_0}\right) = \frac{-t}{RC}$$

$$\text{If } I = \frac{I_0}{2}$$

$$\ln\left(\frac{1}{2}\right) = \frac{-t}{RC}$$

$$t = RC \times \ln 2 = 35 \text{ s}$$

- 79 (a) time constant = $RC = 1 \times 10 \times 10^{-6}$
 $= 1 \times 10^{-5} \text{ s}$, so the capacitor will be fully charged after 1 s

- (b) Initially pd across $C =$ pd across R

$$V_c = 5 \text{ V}$$

$$5 = IR$$

$$I = \frac{5}{0.5 \times 10^6}$$

$$I = 1 \times 10^{-5} \text{ A}$$

- (c) $RC = 0.5 \times 10^6 \times 10 \times 10^{-6} = 5 \text{ s}$

$$V = V_0 e^{-\frac{t}{RC}} = 5 \times e^{-\frac{2}{5}} = 3.35 \text{ V}$$

Practice questions

1 $E = 8.1 \times 10^3 \text{ J}$

$$Q = 5.8 \times 10^3 \text{ C}$$

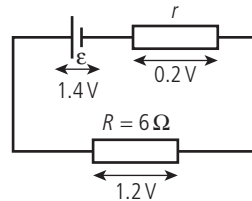

(i) $\text{emf} = \text{energy per coulomb} = \frac{8.1 \times 10^3}{5.8 \times 10^3} = 1.4 \text{ V}$

- (ii) If $\epsilon = 1.4 \text{ V}$ and pd across $R = 1.2 \text{ V}$ then pd across $r = 0.2 \text{ V}$
 so $1.4 = 0.2 + 1.2$, as shown

If you go up 1.4 V you must come down 1.4 V.

Applying Ohm's law to R

$$I = \frac{V}{R} = \frac{1.2}{6} = 0.2 \text{ A}$$

Applying Ohm's law to r

$$r = \frac{V}{I} = \frac{0.2 \text{ V}}{0.2 \text{ A}} = 1.0 \Omega$$

- (iii) Charge flowing = $5.8 \times 10^3 \text{ C}$

Potential difference across $R =$ energy converted to heat per unit charge

So energy converted in $R = \text{pd} \times Q$

$$= 1.2 \times 5.8 \times 10^3 = 6.9 \times 10^3 \text{ J}$$

- (iv) Current is made up of electron flow, as electrons flow through the metal they interact (collide) with the metal atoms, giving them energy. This is rather like the way a rubber ball gives energy to the steps as it falls down the stairs. Increased vibration of the atomic lattice results in an increase in temperature.

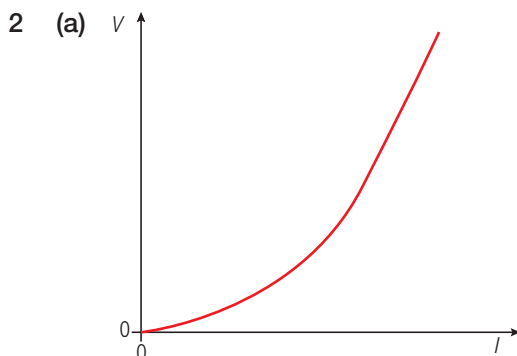

(b) (i) Resistance = $\frac{V}{I}$; this can be found by dividing V by I .

(ii) Non-ohmic since the graph is not linear. An ohmic resistor should have a constant value for R .

(c) $I = 120\text{mA}$ $V = 6.0\text{V}$

(i) $R = \frac{V}{I} = \frac{6.9}{120 \times 10^{-3}} = 50\ \Omega$

(ii)

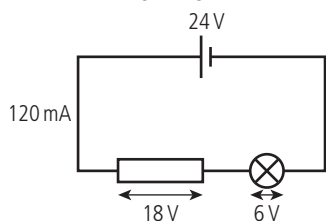

If a resistor R is connected in series then the total pd across R and bulb = 24V.

pd across bulb = 6V

so pd across R = 18V

pd across R = 18V

$$R = \frac{V}{I}$$

$$= \frac{18}{120 \times 10^{-3}} = 150\ \Omega$$

3 (a) (i) This means that if the bulb is connected to 3V then 0.6W of power is dissipated.

(ii) $P = IV \Rightarrow I = \frac{P}{V} = \frac{0.6}{3} = 0.2\text{A}$

(b) (i) Minimum value is when R is maximum; this can only be zero if maximum value of R is infinite.

Maximum value of current is when R is zero. Ideally the pd across the bulb would then be 3V but it isn't because the circuit and battery have resistance.

(ii)

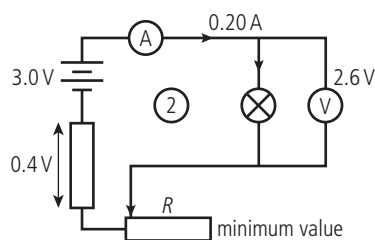
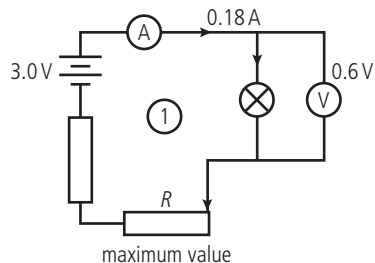

If we look at circuit (2) we see that the pd across the internal resistance is 0.4V.

Now $I = 0.2\text{A}$

$$\text{So } R = \frac{V}{I} = \frac{0.4}{0.2} = 2.0\ \Omega$$

(c) (i) Apply Ohm's law: $I = 0.18\text{A}$, $V = 0.6\text{V}$

$$R = \frac{V}{I} = \frac{0.4}{0.2} = 3.3\ \Omega$$

(ii) Ohm's law again: $I = 0.2\text{A}$, $V = 2.6\text{V}$

$$R = \frac{V}{I} = \frac{2.6}{0.2} = 13\ \Omega$$

(d) Resistance is different because temperature of bulb is greater in c(ii)

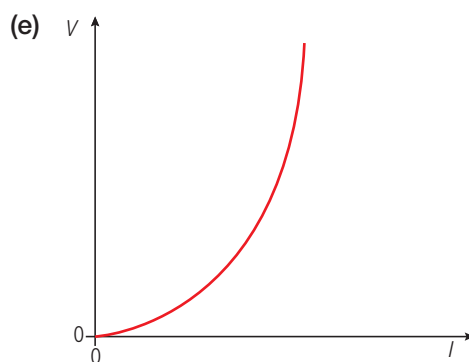

(f) The circuit is the same as this:

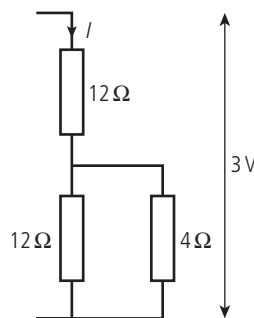

First calculate resistance of the 12Ω and 4Ω resistors in parallel:

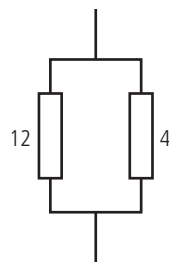

$$\frac{1}{R_T} = \frac{1}{12} + \frac{1}{4} = \frac{1+3}{12} = \frac{4}{12}$$

$$R_T = \frac{12}{4} = 3\ \Omega$$

Now add the other 12Ω

$$R = 12 + 3 = 15\Omega$$

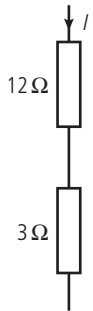

Total $R = 15\Omega$; apply Ohm's law to the whole combination $\rightarrow I = \frac{V}{R} = \frac{3}{15} = 0.2\text{A}$

Applying Ohm's law to the 12Ω resistor

$$\rightarrow V = IR = 0.2 \times 12 = 2.4\text{V}$$

so the pd across the bulb must be

$$3 - 2.4 = 0.6\text{V}$$

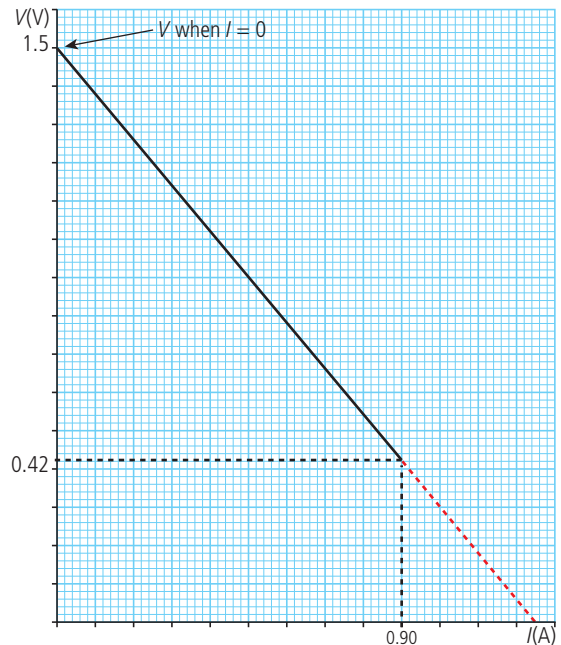

- 4 (a) (i) Power from cell = emf \times current = EI

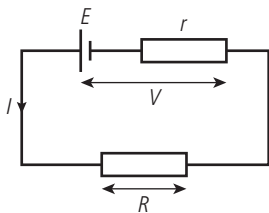

emf is $\frac{\text{energy converted}}{\text{charge}}$

$$\text{so emf} \times \text{current} = \frac{\text{energy}}{\text{charge}} \times \frac{\text{charge}}{\text{time}} = \frac{\text{energy}}{\text{time}} = \text{power}$$

- (ii) Power dissipated in cell = power dissipated in $r = I^2r$

- (iii) Power dissipated in external circuit = $I^2R = IV$

- (b) From the law of conservation of energy: power from cell = power dissipated in circuit

$$EI = I^2r + VI \Rightarrow E = V + Ir$$

- (c)

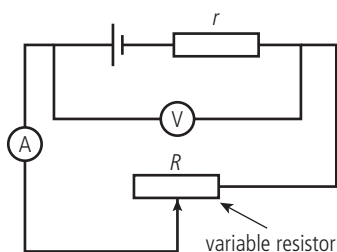

- (d) (i) When I is zero there will be no pd across r , so $V = E \Rightarrow E = 1.5\text{V}$
 (ii) If the resistance R is very small then $V = 0$
 so current can be found from the intercept on the I axis $\approx 1.3\text{A}$
 (iii) When $R = 0$ pd across $r = 1.5\text{V}$
 so $r = \frac{V}{I} = \frac{1.5}{1.3} = 1.2\Omega$

- (e) If $R = r$ then R must equal 1.2Ω

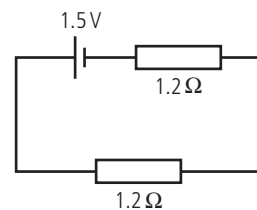

So total $R = 2.4\Omega$

$$\text{Ohm's law} \rightarrow I = \frac{V}{R} = \frac{1.5}{2.4}\text{A}$$

$$\text{Power} = I^2R = \left(\frac{1.5}{2.4}\right)^2 \times 1.2 = 0.48\text{W}$$

- 5 (a) Gravitational field strength is the force experienced per unit mass by a small test mass placed in the field.

- (b) Should be $GM = g_0R^2$

From Newton's law the force on a mass m on the surface of the Earth $F = \frac{GMm}{R^2}$

$$\text{Field strength } g_0 = \frac{F}{m} = \frac{GMm}{R^2m} \Rightarrow g_0 = \frac{GM}{R^2} \Rightarrow GM = g_0R^2$$

(c) Use Fleming's right hand rule

(d) $F = B \cos \theta \times v \times e$

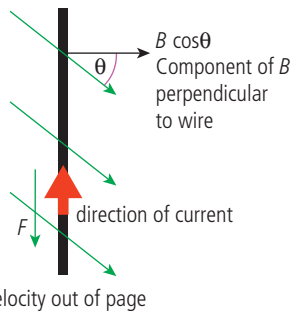

(e) $E =$ energy converted from mechanical work to electrical PE per unit charge.
Work done on an electron in pushing it along the wire = force \times distance

$$= B \cos \theta \times ev \times L$$

$$\text{Work done per unit charge} = \frac{WD}{e}$$

$$= B \cos \theta \times vL$$

This is the correct answer since question says deduce from (d). However a more obvious solution uses Faraday's law.

$E =$ rate of flux cut

$$= B \cos \theta \times \text{area swept out per second}$$

$$= B \cos \theta \times vL \text{ since wire moves a distance } v \text{ in 1 second.}$$

(f) For an orbiting body the gravitational force = centripetal force

$$\text{so } \frac{GMm}{R^2} = \frac{mv^2}{R}$$

(where R is the orbit radius)

$$\text{so } v = \sqrt{\frac{GM}{R}}$$

From the question we know that for the

$$\text{Earth's surface } GM = g_0 R_0^2$$

(where R_0 is the Earth's radius)

$$= 10 \times (6.4 \times 10^6)^2$$

$$\text{So } GM = 4.1 \times 10^{14} \text{ Nm}^2 \text{ kg}^{-1}$$

$$\text{Height} = 3 \times 10^5 \text{ m}$$

$$\text{so } R = 3 \times 10^5 + 6.4 \times 10^6 = 6.7 \times 10^6 \text{ m}$$

$$\text{so } v = \sqrt{\frac{4.1 \times 10^{14}}{6.7 \times 10^6}} = \sqrt{6.1 \times 10^7}$$

$$= 7.8 \times 10^3 \text{ ms}^{-1}$$

(g) From answer to (e), $E = B \cos \theta \times vL$

$$\text{so } E = 6.3 \times 10^{-6} \cos 20^\circ \times 7.8 \times 10^3 \times L = 1000V$$

$$L = \frac{1000}{6.3 \times 10^{-6} \cos 20^\circ \times 7.8 \times 10^3}$$

$$= 2.2 \times 10^4 \text{ m}$$

Error carried forward: In IB questions you generally don't get penalized for carrying an error forward so if you got part (e) wrong and used your answer in part (g), then you should get the marks for (g).

6 (a) (i) The emf induced in a conductor placed in a magnetic field is directly proportional to the rate of change of the flux it encloses.

(ii) The loop encloses B field as shown. If the current changes then the enclosed flux field will change so, according to Faraday, emf will be induced.

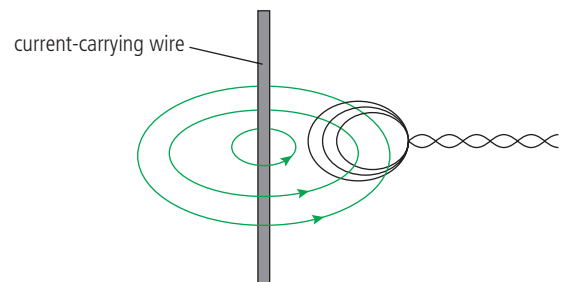

(b) When gradient of B versus t is maximum then ϵ is maximum.

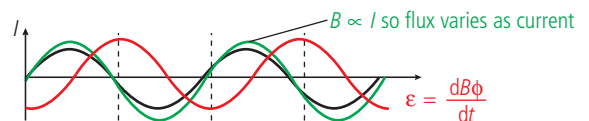

(iii) When coil is further from the wire, the B field will be less so flux enclosed will be smaller.

As a result $\frac{dN\phi}{dt}$ is less so ϵ is less.

(c) Advantage – does not need to be in contact with the wire.

Disadvantage – distance from the wire should be known.

7

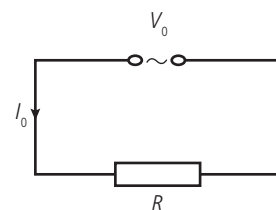

$$\text{Power} = V_{\text{rms}} I_{\text{rms}}$$

$$\text{where } V_{\text{rms}} = \frac{V_0}{\sqrt{2}} \text{ and } I_{\text{rms}} = \frac{I_0}{\sqrt{2}}$$

$$\text{Power} = \frac{V_0 I_0}{2}$$

The answer is A.

- 8 For an ideal transformer no power is lost.
power in = power out

$$V_p I_p = V_s I_s$$

The answer is C.

This is always true only if the transformer is ideal; however, none of the other answers makes any sense.

Challenge yourself

- 1 The situation looks like this:

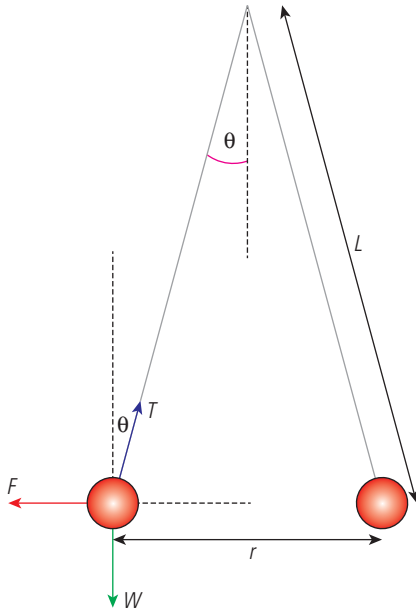

Taking components:

$$\text{vertical } T \cos \theta = mg$$

$$\text{horizontal } T \sin \theta = F \text{ (the electric force)}$$

$$\text{Dividing gives } \tan \theta = \frac{F}{mg}$$

but the angle is small so we can approximate:

$$\tan \theta \approx \frac{(r/2)}{L} = \frac{r}{2L}$$

$$\text{We also know that } F = \frac{kQ_1 Q_2}{r^2} = \frac{kQ^2}{r^2},$$

with each sphere taking half of the total charge ($5.5 \times 10^{-10} \text{ C}$)

$$\text{so } \frac{r}{2L} = \frac{(kQ^2/r^2)}{mg}$$

$$\text{rearranging, we find } r^3 = \frac{kQ^2 \times 2L}{mg}$$

$$= \frac{(9 \times 10^9 \times (5.5 \times 10^{-10})^2 \times 2 \times 0.5)}{(10 \times 10^{-6} \times 10)}$$

$$= 2.7 \times 10^{-5}$$

and $r = 3 \text{ cm}$

- 2 A vacuum cleaner has an electric motor, which consists of a coil rotating in a magnetic field. When a coil rotates in a magnetic field an emf will be induced in it that opposes the change producing it. This means that the induced emf will oppose the current flowing through the coil. If there were no resistance this emf would equal the applied emf and no current would flow. When the motor starts there is no induced emf (back emf) opposing the current so the current is much larger than when running. This can cause the circuit breaker in the house to switch off. To prevent this a variable resistor could be placed in series with the motor; this is reduced as the motor starts to rotate.

- 3

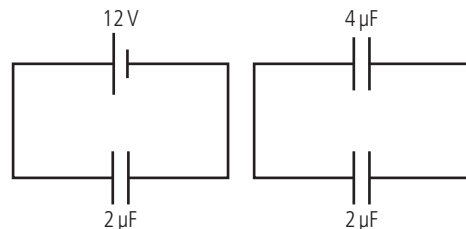

When connected to the battery

$$Q = CV = 24 \mu\text{C}$$

$$\text{Energy stored} = \frac{1}{2} CV^2 = 0.5 \times 2 \times 10^{-6} \times 12^2 = 144 \mu\text{J}$$

When connected to the other capacitor the total charge is conserved and the pd across each is the same.

$$Q = Q_1 + Q_2$$

$$V = V_1 = V_2$$

$$\text{So } Q = C_1 V_1 + C_2 V_2 = C_1 V + C_2 V$$

$$24 = 4V + 2V$$

$$V = 4V$$

$$\text{Energy stored} = \frac{1}{2} C_1 V^2 + \frac{1}{2} C_2 V^2$$

$$= 0.5 \times 4 \times 10^{-6} \times 4^2 + 0.5 \times 2 \times 10^{-6} \times 4^2 = 48 \mu\text{J}$$

$$\text{Change} = 96 \mu\text{J}$$

Worked solutions

Chapter 7

Exercises

- 1 (a) $KE_{\max} = V_s e = 0.6 \times 1.6 \times 10^{-19}$
 $= 9.6 \times 10^{-20} \text{ J}$
- (b) $\lambda = 422 \text{ nm} \rightarrow f = \frac{c}{\lambda} = 7.1 \times 10^{14} \text{ Hz}$
- (c) $KE_{\max} = hf - \phi \Rightarrow \phi = hf - KE_{\max}$
 $= 6.63 \times 10^{-34} \times 7.1 \times 10^{14} - 9.6 \times 10^{-20}$
 $= 3.7 \times 10^{-19} \text{ J}$
- (d) $\phi = hf_0 \Rightarrow f_0 = \frac{\phi}{h} = \frac{3.7 \times 10^{-19}}{6.67 \times 10^{-34}}$
 $= 5.6 \times 10^{14} \text{ Hz}$
- 2 (a) $f = \frac{c}{\lambda} = 2.1 \times 10^{15} \text{ Hz}$
 $\lambda = 144 \text{ nm}, \phi = 4.3 \text{ eV}$
 $E = hf = 6.63 \times 10^{-34} \times 2.1 \times 10^{15}$
 $= 1.38 \times 10^{-18} \text{ J}$
 $1 \text{ eV} = 1.6 \times 10^{-19} \text{ J}$
 $E(\text{eV}) = \frac{1.38 \times 10^{-18}}{1.6 \times 10^{-19}} = 8.6 \text{ eV}$
- (b) $KE_{\max} = hf - hf_0 = 8.6 - 4.3 = 4.3 \text{ eV}$
- (c) $KE_{\max} = V_s e = 4.3 \text{ eV}$
 $V_s = 4.3 \text{ V}$
- (d) $hf_0 = 4.3 \times 1.6 \times 10^{-19}$
 $f_0 = \frac{4.3 \times 1.6 \times 10^{-19}}{6.63 \times 10^{-34}}$
 $f_0 = 1.0 \times 10^{15} \text{ Hz}$
- 3 No electrons emitted since
 $7.1 \times 10^{14} < 1.0 \times 10^{15}$
- 4 $KE_{\max} = hf - \phi, KE_{\max} = 1.4 \text{ eV}, \phi = 5.0 \text{ eV}$
 $hf = KE_{\max} + \phi$
 $= 1.4 + 5.0 = 6.4 \text{ eV}$
 $hf_0 = 6.4 \times 1.6 \times 10^{-19} \text{ J} \Rightarrow f_0 = \frac{6.4 \times 1.6 \times 10^{-19}}{h}$
 $= 1.5 \times 10^{15} \text{ Hz}$

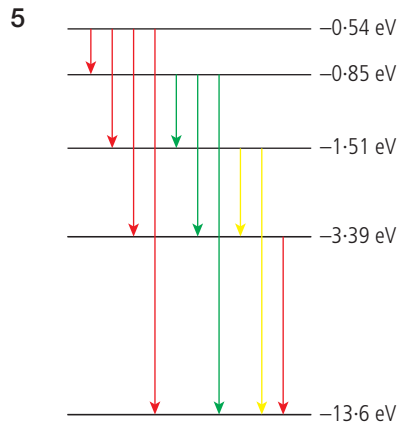

10 possible transitions as shown.

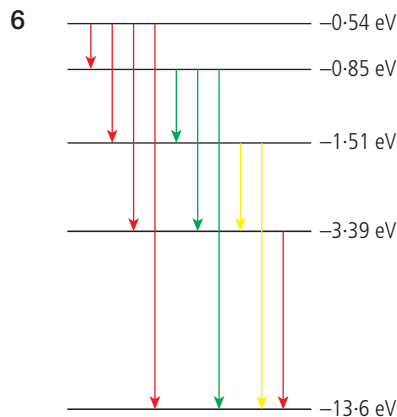

The maximum energy is released from the biggest transition.

i.e. from $-0.54 \rightarrow -13.6 \text{ eV}$

Energy released = $13.6 - 0.54 \text{ V} = 13.06 \text{ eV}$

This is equivalent to $13.06 \times 1.6 \times 10^{-19} \text{ J}$
 $= 2.09 \times 10^{-18} \text{ J}$

Using the equation $E = hf$

$$f = \frac{E}{h} = \frac{2.09 \times 10^{-18}}{6.63 \times 10^{-34}}$$

$$f = 3.15 \times 10^{15} \text{ Hz}$$

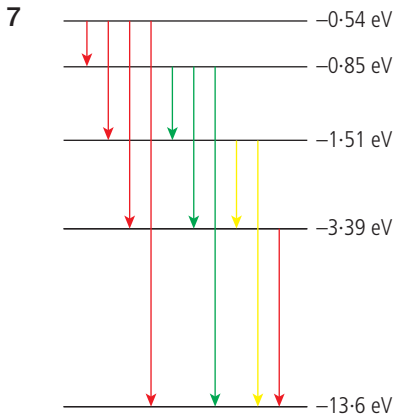

The minimum energy is given by the smallest transition.

$$-0.54 \rightarrow -0.85$$

$$E = 0.85 - 0.54 = 0.31 \text{ eV}$$

$$\text{This is equivalent to } 0.31 \times 1.6 \times 10^{-19} \text{ J} \\ = 4.96 \times 10^{-20} \text{ J}$$

Using $E = hf$

$$f = \frac{E}{h} = \frac{4.96 \times 10^{-20}}{6.63 \times 10^{-34}} = 7.44 \times 10^{13} \text{ Hz}$$

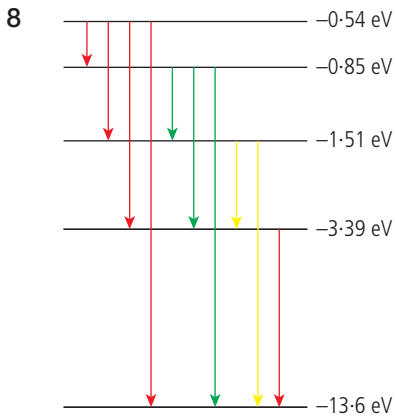

To remove an electron from the lowest energy level it must be given 13.6 eV

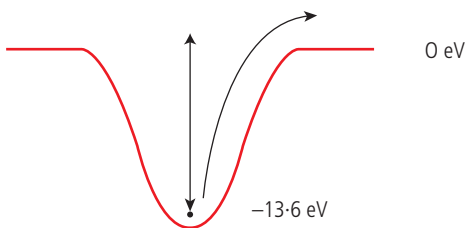

$$\text{This is } 13.6 \times 1.6 \times 10^{-19} \text{ J} = 2.18 \times 10^{-18} \text{ J}$$

Using $E = hf$

$$f = \frac{E}{h} = \frac{2.18 \times 10^{-18}}{6.63 \times 10^{-34}} = 3.28 \times 10^{15} \text{ Hz}$$

9
$$r = \frac{\epsilon_0 n^2 h^2}{\pi m e^2}$$

Use $n = 1$ to find radius of atom when in lowest energy state

$$r = \frac{8.85 \times 10^{-12} \times 1 \times (6.63 \times 10^{-34})^2}{\pi \times 9.1 \times 10^{-31} \times (1.6 \times 10^{-19})^2} \\ = 5.3 \times 10^{-11} \text{ m}$$

10
$$E = -13.6/n^2 \text{ eV}$$

$$\Delta E = -13.6 \left(\frac{1}{n_2^2} - \frac{1}{n_1^2} \right)$$

$$= -13.6 \left(\frac{1}{2^2} - \frac{1}{1} \right) = -10.2 \text{ eV}$$

$$\Delta E = hf, \text{ so } f = \frac{\Delta E}{h} = \frac{(10.2 \times 1.6 \times 10^{-19})}{6.63 \times 10^{-34}} \\ = 2.5 \times 10^{15} \text{ Hz}$$

11 (a) $\text{KE} = 100 \text{ eV}, V = 100 \text{ V}$

(b) $1 \text{ eV} = 1.6 \times 10^{-19} \text{ J}$

$$100 \text{ eV} = 100 \times 1.6 \times 10^{-19} \text{ J}$$

$$\text{KE} = 1.6 \times 10^{-17} \text{ J}$$

(c) $\text{KE} = \frac{1}{2} mv^2 \rightarrow v = \sqrt{\frac{2 \times \text{KE}}{m}}$

$$= \sqrt{\frac{2 \times 1.6 \times 10^{-17}}{9.1 \times 10^{-31}}} = 5.9 \times 10^6 \text{ ms}^{-1}$$

$$\text{Momentum } p = mv = 9.1 \times 10^{-31} \times 5.9 \times 10^6 \\ = 5.4 \times 10^{-24} \text{ kg ms}^{-1}$$

$$\lambda = \frac{h}{p} = \frac{6.63 \times 10^{-34}}{5.4 \times 10^{-24}} = 1.2 \times 10^{-10} \text{ m}$$

12 Momentum of car = $1000 \times 15 = 1.5 \times 10^4 \text{ N s}$

$$\lambda = \frac{h}{p} = 4.4 \times 10^{-38} \text{ m}$$

Can't pass a car through such a small opening.

13 Size of nucleus is about 10^{-15} m

$$\Delta x \approx 10^{-15} \text{ m}$$

$$\Delta x \Delta p > h/4\pi$$

$$\Delta p > \frac{h}{4\pi} \div 10^{-15}$$

$$\Delta p \approx 5 \times 10^{-20} \text{ N s}$$

$$\text{KE} = \frac{1}{2} mv^2 = \frac{p^2}{2m} = \frac{(5 \times 10^{-20})^2}{2 \times 9.1 \times 10^{-31}} \\ = 1.4 \times 10^{-9} \text{ J} \\ = 8.6 \text{ GeV (far too much)}$$

14 $KE = \frac{1}{2}mv^2 = \frac{1}{2} \times 1000 \times 20^2 = 2 \times 10^5 \text{ J}$

mass equivalent from $E = mc^2$

$$m = \frac{2 \times 10^5}{(3 \times 10^8)^2} = 2.2 \times 10^{-12} \text{ kg}$$

15 (a) $E = Vq = 500 \text{ eV}$

(b) $1 \text{ eV} = 1.6 \times 10^{-19} \text{ J}$

$$500 \text{ eV} = 500 \times 1.6 \times 10^{-19} = 8 \times 10^{-17} \text{ J}$$

(c) mass equivalent = $\frac{8 \times 10^{-17}}{(3 \times 10^8)^2}$
 $= 8.9 \times 10^{-34} \text{ kg}$

(d) mass equivalent = $8.9 \times 10^{-34} \times \frac{(3 \times 10^8)^2}{1.6 \times 10^{-19}}$
 $= 500 \text{ eVc}^{-2}$

16 (a) 35 protons + neutrons

17 protons

$$\text{number of neutrons} = 35 - 17 = 18$$

(b) 58 protons + neutrons

28 protons

$$\text{number of neutrons} = 58 - 28 = 30$$

(c) 204 protons + neutrons

82 protons

$$\text{number of neutrons} = 204 - 82 = 122$$

17 $^{54}_{26}\text{Fe}$ has 26 protons. Each proton has charge
 $+ 1.6 \times 10^{-19} \text{ C}$

$$\Rightarrow \text{Charge of nucleus} = 26 \times 1.6 \times 10^{-19} \text{ C}$$

$$= 4.16 \times 10^{-18} \text{ C}$$

Total number of protons + neutrons = 54

A proton and a neutron have a mass

$$\approx 1.67 \times 10^{-27} \text{ kg each}$$

Approximate mass of nucleus

$$= 54 \times 1.67 \times 10^{-27} = 9.0 \times 10^{-26} \text{ kg}$$

18 92 protons + 143 neutrons \Rightarrow atomic mass
 $= 235$

So nuclear symbol is $^{235}_{92}\text{U}$

19 $^{238}_{92}\text{U}$ has 92 protons and $238 - 92 = 146$
 neutrons

A different isotope would have 92 protons but a
 different number of neutrons, e.g. 145.

20 Charge of alpha particle = $2e = 2 \times 1.6 \times$
 $10^{-19} \text{ C} = 3.2 \times 10^{-19} \text{ C}$

(a) KE of alpha particle = 7.7 MeV

$$= 7.7 \times 10^6 \times 1.6 \times 10^{-19} \text{ J}$$

$$= 1.23 \times 10^{-12} \text{ J}$$

$$KE = \frac{1}{2}mv^2 \Rightarrow v = \sqrt{\frac{2KE}{m}}$$

$$= \sqrt{\frac{2 \times 1.23 \times 10^{-12}}{6.7 \times 10^{-27}}}$$

$$v = 1.9 \times 10^7 \text{ ms}^{-1}$$

(b) When alpha particle is closest to nucleus,

KE = electrical PE

$$\Rightarrow 1.23 \times 10^{-12} = \frac{kQq}{r}$$

$$r = \frac{9 \times 10^9 \times 2.1 \times 10^{-18} \times 3.2 \times 10^{-19}}{1.23 \times 10^{-12}}$$

$$r = 4.9 \times 10^{-15} \text{ m}$$

21

Z	Symbol	A	Mass (u)
92	U	233	233.0396

(a) Z is the number of protons = 92 p

$$A - Z \text{ is the number of neutrons} = 233 - 92 = 141 \text{ n}$$

(b) Total mass (u)

$$= 92 \times 1.00782 + 141 \times 1.00866$$

$$= 234.9405 \text{ u}$$

(c) Mass defect = mass (parts) - mass
 (nucleus)

$$= 234.9405 - 233.0396 = 1.9009 \text{ u}$$

(d) Total binding energy = 1.9009×931.5

$$= 1770.6 \text{ MeV}$$

(e) There are 233 nucleons so

$$BE/\text{nucleon} = \frac{1770.6}{233} = 7.6 \text{ MeV/nucleon}$$

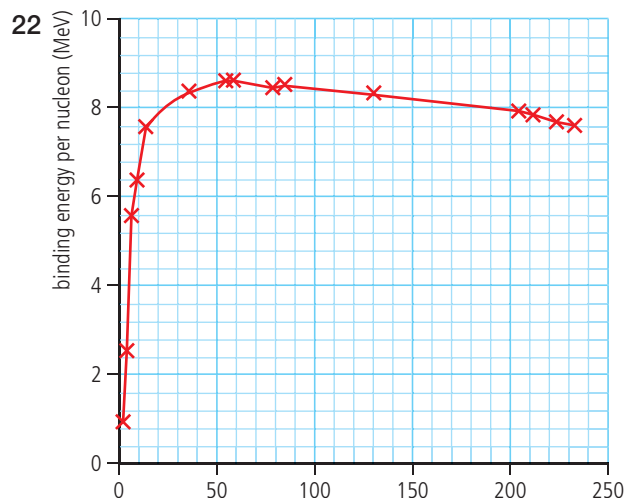

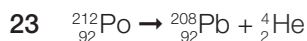

$$E \text{ released} = [\text{mass (Po)} - (\text{mass (Pb)} + \text{mass (He)})] \times 931.5 \text{ MeV}$$

$$= 8.95 \text{ MeV}$$

24 The proposed decay equation is

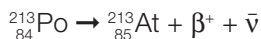

Energy released

$$= [\text{mass (Po)} - \text{mass (At)}] \times 931.5 \text{ MeV}$$

$$= -73 \text{ keV}$$

This is negative (meaning energy would need to be supplied to make it happen) so won't happen naturally.

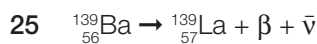

Energy released

$$= [\text{mass (Ba)} - \text{mass (La)}] \times 931.5 \text{ MeV}$$

$$= 2.32 \text{ MeV}$$

26 $\Delta E = \gamma$ energy

$$5.485 - 5.443 = 0.042 \text{ MeV}$$

$$E = hf; f = \frac{\Delta E}{h} = \frac{0.042 \times 10^6 \times 1.6 \times 10^{-19}}{6.63 \times 10^{-34}}$$

$$= 1.0 \times 10^{19} \text{ Hz}$$

27 Half-life is 4 s, so 16 s is 4 half-lives, so sample will halve 4 times.

Original sample contained 200 g so after 4 half-lives will contain

$$200 \times \frac{1}{2} \times \frac{1}{2} \times \frac{1}{2} \times \frac{1}{2} = 12.5 \text{ g}$$

28 Rate of decay halves each half-life.

Half-life is 15 s so 42 s is 3 half-lives.

If activity was 100 decay/s then after 42 s it will be

$$100 \times \frac{1}{2} \times \frac{1}{2} \times \frac{1}{2} = 12.5 \text{ decay/s}$$

29 $\frac{1}{16}$ is $\frac{1}{2} \times \frac{1}{2} \times \frac{1}{2} \times \frac{1}{2}$ so if the amount of ${}^{14}\text{C}$ has reduced to $\frac{1}{16}$ the wood is 4 half-lives of ${}^{14}\text{C}$ old
 $= 4 \times 6000 = 24000$ years.

30 $A_0 = 40 \text{ Bq}; t_{\frac{1}{2}} = 5 \text{ mins}$

$$\lambda = \frac{\ln 2}{5} = 0.14 \text{ min}^{-1}$$

$$A_t = A_0 e^{-\lambda t}$$

$$t = 12 \text{ min}$$

$$A_t = 40 \times e^{-0.14 \times 12} = 7.45 \text{ Bq}$$

31 $A_t = A_0 e^{-\lambda t}; A_0 = 20 \text{ Bq}$

$$\ln\left(\frac{A_t}{A_0}\right) = -\lambda t; A_t = 15.7 \text{ Bq}$$

$$\lambda = \ln\left(\frac{A_0}{A_t}\right) \times \frac{1}{t} = \ln\left(\frac{20}{15.7}\right) \times \frac{1}{10}$$

$$= 2.4 \times 10^{-2} \text{ year}^{-1}$$

$$t_{\frac{1}{2}} = \frac{\ln 2}{\lambda} = 28.6 \text{ years}$$

32 (a) $5.27 \text{ years} = 5.27 \times 365 \times 24 \times 60 \times 60$
 $= 1.66 \times 10^8 \text{ s}$

(b) $\lambda = \frac{\ln 2}{t_{\frac{1}{2}}} = 4.17 \times 10^{-9} \text{ s}^{-1}$

(c) ${}^{60}\text{Co}$ has mass no 60

$$\Rightarrow 60 \text{ g contains } 6.02 \times 10^{23} \text{ atoms}$$

$$\Rightarrow 1 \text{ g contains}$$

$$\frac{1}{60} \times 6.02 \times 10^{23} = 1.0 \times 10^{22} \text{ atoms}$$

(d) Activity = $\frac{dN}{dt} = -\lambda N$

$$= 4.17 \times 10^{-9} \times 1.0 \times 10^{22} = 4.17 \times 10^{13} \text{ s}^{-1}$$

(e) If activity = 50 Bq then sample contains

$$\frac{50}{4.17 \times 10^3} = 1.2 \times 10^{-12} \text{ g}$$

33 (a) ${}^2_1\text{H} + {}^2_1\text{H} \rightarrow {}^3_2\text{He} + {}^1_0\text{n}$

Change in mass

$$= [2.014101 + 2.014101]$$

$$- [3.016029 + 1.008664]$$

$$= 0.003509 \text{ u}$$

$$\text{Energy released} = 0.003509 \times 931.5$$

$$= 3.268 \text{ MeV}$$

(b) ${}^2_1\text{H} + {}^2_1\text{H} \rightarrow {}^3_1\text{H} + {}^1_1\text{p}$ (${}^1_1\text{H}$ is a proton)

Change in mass

$$= [2 \times 2.014101] - [3.016049 + 1.007825]$$

$$= 0.004328 \text{ u}$$

$$\text{Energy released} = 0.004328 \times 931.5$$

$$= 4.032 \text{ MeV}$$

(c) ${}^2_1\text{H} + {}^3_2\text{He} \rightarrow {}^4_2\text{He} + {}^1_1\text{p}$

Change in mass

$$= [2.014101 + 3.016029]$$

$$- [4.002603 + 1.007825]$$

$$= 0.019702 \text{ u}$$

$$\text{Energy released} = 0.019702 \times 931.5$$

$$= 18.35 \text{ MeV}$$

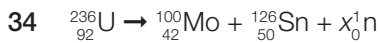

To balance nucleon number

$$236 = 100 + 126 + x \times 1$$

$$x = 10$$

To calculate energy released, first find change in mass:

$$236.045563 - [99.907476 + 125.907653 + 10 \times 1.008664] = 0.1438 \text{ u}$$

$$\text{Energy released} = 0.1438 \times 931.5 = 133.9 \text{ MeV}$$



Change in mass

$$= 233.039628 - [137.905233 + 85.910615 + 9 \times 1.008664] = 0.1458 \text{ u}$$

$$\text{Energy released} = 0.1458 \times 931.5 \text{ MeV} = 135.8 \text{ MeV}$$

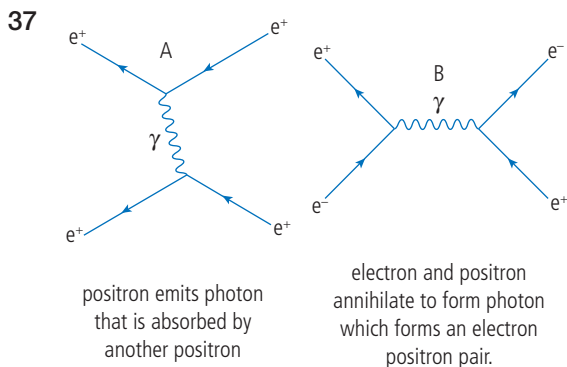
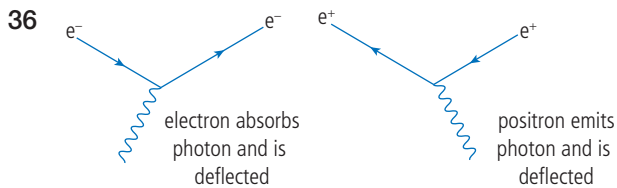

e^- and e^+ can be swapped in all cases to give an equally valid answer

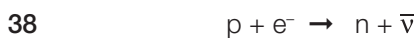

Baryon $1 + 0 \rightarrow 1 + 0$

Lepton $0 + 1 \rightarrow 0 + 1$

Charge $+1 - 1 \rightarrow 0 + 0$

Seems ok

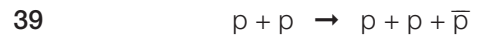

No \rightarrow Baryon $1 + 1 \rightarrow 1 + 1 + -1$

Lepton $0 + 0 \rightarrow 0 + 0 + 0$

No \rightarrow Charge $1 + 1 \rightarrow 1 + 1 - 1$

Not ok

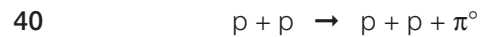

Baryon $1 + 1 \rightarrow 1 + 1 + 0$

Lepton $0 + 0 \rightarrow 0 + 0 + 0$

Charge $1 + 1 \rightarrow 1 + 1 + 0$

Seems ok



Baryon $1 + -1 \rightarrow 0 + 0$

Lepton $0 + 0 \rightarrow 0 + 0$

Charge $1 + -1 \rightarrow 0 + 0$

Seems ok



Baryon $0 + 0 \rightarrow 0 + 0$

Lepton $1 - 1 \rightarrow 0 + 0$

Charge $-1 - 1 \rightarrow 0 + 0$

Seems ok



No \rightarrow Baryon $0 + 0 \rightarrow 1 + 0$

No \rightarrow Lepton $1 - 1 \rightarrow 0 + 0$

Charge $-1 + 1 \rightarrow 0 + 0$

Not ok



No \rightarrow Baryon $1 + -1 \rightarrow 1 + 0$

No \rightarrow Lepton $0 + 0 \rightarrow 0 + -1$

Charge $+1 - 1 \rightarrow 0 + 0$

Not ok

- 45 (a) π^- : charge -1 , strangeness $= 0$
Mesons are quark-antiquark combinations

$$\bar{u} d$$

$$-\frac{2}{3} - \frac{1}{3} \rightarrow \text{total change} = -1$$

- (b) Ω^- : charge -1 , strangeness $-3 \rightarrow s s s$
(c) Ξ^- : charge -1 , strangeness $-2 \rightarrow s s d$
charge $-\frac{1}{3} - \frac{1}{3} - \frac{1}{3}$
(d) Ξ^0 : charge 0 , strangeness -2

$$s s u$$

$$\text{charge } -\frac{1}{3} - \frac{1}{3} - \frac{1}{3}$$

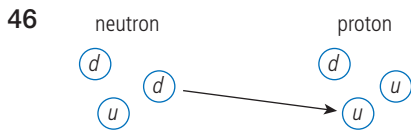

Down changes to up

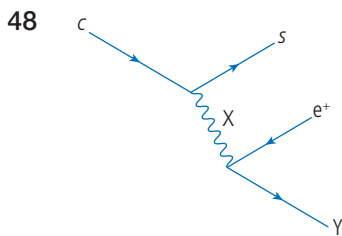
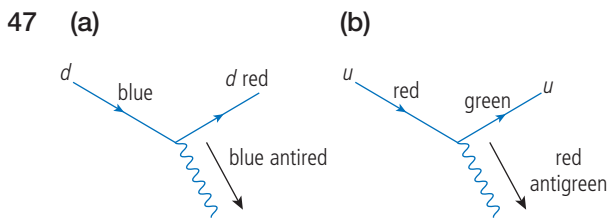

If one arrow points into vertex the other must point out so Y arrow points out, this is forwards in time so Y is a neutrino.

Charge exchange is positive so X is a W^+ .

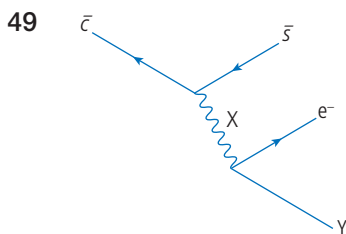

Y arrow must point in so is antineutrino.

Charge exchange is negative so X is a W^- .

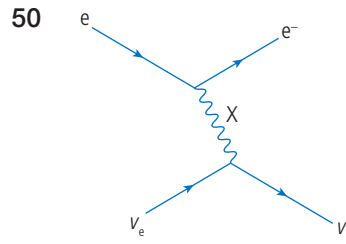

Weak interaction but no exchange of charge so X is a Z^0

Practice questions

- 1 (a) (i) When white light passes through a gas photons can excite atomic electrons into higher energy levels. When this happens the photon is absorbed resulting in a dark line in the spectrum. After absorption the electron will go back to its original level, re-emitting the photon in a random direction.

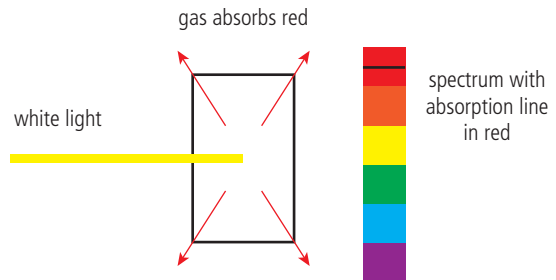

- (ii) To produce a spectrum the light can be passed through a diffraction grating; this will produce interference maxima for each colour at a different angle.

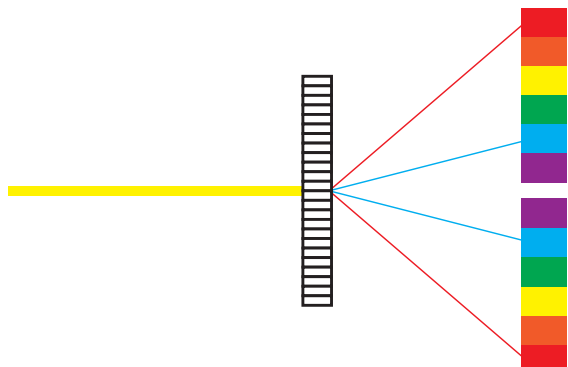

(b) (i) $E = hf$ where $f = \frac{c}{\lambda}$
 so $E = \frac{hc}{\lambda} = \frac{6.63 \times 10^{-34} \times 3 \times 10^8}{588 \times 10^{-9}}$
 $= 3.38 \times 10^{-19} \text{ J}$

(ii) According to the previous calculation absorption of a 588 nm photon will give an atomic electron $3.38 \times 10^{-19} \text{ J}$ of energy. This would correspond to a change from the -5.8 to the -2.42 level.

$$5.8 - 2.42 = 3.38$$

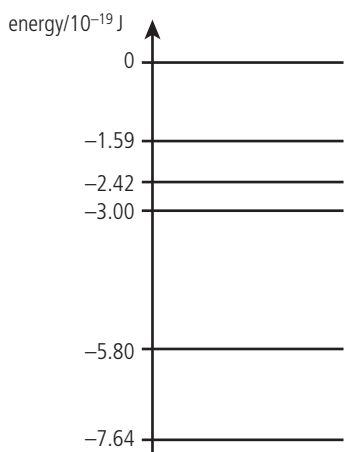

(To answer this simply try subtracting 3.38 from each level.)

(c) (i) The Bohr model assumes that electrons orbit the nucleus, like planets orbiting the Sun. To explain the line spectrum of hydrogen, the electrons can only exist in certain stable orbits defined by their angular momentum. Absorption of a photon of light causes the electrons to change to a larger orbit.

(ii) The Schrödinger model considers the atomic electrons to behave as waves trapped in the potential well of the nucleus. Like standing waves in a string, the 'electron wave' can only have certain discrete wavelengths and therefore discrete energies.

(d) The temperature of the core of the Sun is so high that all atoms would be ionized; this means that chemical reactions such as burning could not take place. Spectral analysis of the Sun shows that it is mostly H and He so the reaction taking place is fusion not fission. The amount of energy produced is also of the right order of magnitude.

(e) (i) Balancing the nucleon numbers (atomic mass number) $4 + 4 + 4 = 12$
 Balancing proton number (atomic number) $2 + 2 + 2 = 6$

(ii) The energy released is due to loss in mass

Mass defect = $3 \times \text{mass of He} - \text{mass of C}$

$$3 \times 6.648325 \times 10^{-27} - 1.9932000 \times 10^{-26} = 1.2975 \times 10^{-29} \text{ kg}$$

$$\text{This is equivalent to } mc^2 \text{ energy} = 1.2975 \times 10^{-29} \times (3 \times 10^8)^2 = 1.17 \times 10^{-12} \text{ J}$$

(f) (i) The other particle emitted in beta decay is an antineutrino.

(ii) During beta decay the energy released (change in binding energy) is shared between the daughter, beta particle and neutrino. The daughter has a much bigger mass than the other two so doesn't receive much energy, resulting in most energy being shared between the beta particle and neutrino.

(iii) Using the decay equation $N = N_0 e^{-\lambda t}$ where the decay constant $\lambda = \frac{\ln 2}{\text{half-life}}$
 $= \frac{\ln 2}{0.82} = 0.845 \text{ s}^{-1}$

$$\text{So fraction remaining after } 10 \text{ s} = \frac{N}{N_0} = e^{-0.845 \times 10} = 0.000213, \text{ which is } 0.02\%$$

(iv) During beta decay a neutron decays into a proton + electron

The quark content of a neutron is ddu and a proton is uud

so a down quark has changed into an up quark

- 2 (a) Rate of decay is a nuclear process so is not affected by temperature or pressure of the sample. However the rate of decay does depend on how many nuclei are present.

Property	Increase	Decrease	Stays the same
Temperature			✓
Pressure			✓
Amount	✓		

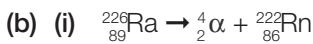

From text given it is α decay so we know $A - 4, Z - 2$

- (ii) (loss of mass) c^2 = energy released

$$\Rightarrow \text{mass (Ra)} > \text{mass } (\alpha + \text{Rn})$$

$$E = [\text{mass(Ra)} - \text{mass } (\alpha + \text{Rn})]c^2$$

$$\Delta m = 226.0254 - (222.0176 + 4.0026) = 0.0052 \text{ u}$$

$$1 \text{ u} \Rightarrow 931.5 \text{ MeV}$$

$$\text{So } E = 0.0052 \times 931.5 = 4.84 \text{ MeV}$$

- c. (i)

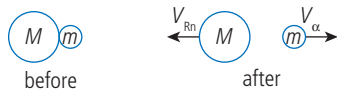

The momentum of the particles before the decay = 0 since the bodies are isolated momentum is conserved so momentum after decay = 0

This means that the momentum of the nucleus is equal and opposite to the momentum of the alpha particle. In other words they move in opposite directions.

(ii) $222 \times v_{\text{Rn}} = -4 \times v_{\alpha}$

$$\Rightarrow \frac{v_{\alpha}}{v_{\text{Rn}}} = -\frac{222}{4} = -55.5$$

(iii) $\text{KE}_{\alpha} = \frac{1}{2} m v_{\alpha}^2$

$$\text{KE}_{\text{Rn}} = \frac{1}{2} m v_{\text{Rn}}^2 \text{ but } m_{\text{Rn}} = \frac{222}{4} \times m_{\alpha} \text{ and}$$

$$v_{\text{Rn}} = \frac{v_{\alpha}}{55.5}$$

$$\text{substituting } \text{KE}_{\text{Rn}} = \frac{1}{2} \left(\frac{222}{4} \right) m_{\alpha} \times \left(\frac{v_{\alpha}}{55.5} \right)^2$$

$$= 0.018 \times \frac{1}{2} m v_{\alpha}^2$$

$$\text{so } \text{KE}_{\text{Rn}} < \text{KE}_{\alpha}$$

- (d) The alpha decay could leave the nucleus in an excited state, leading to the emission of a γ photon.

- (e) (i) Fusion is when two small nuclei join to form a larger nucleus with higher binding energy. This results in the release of energy.

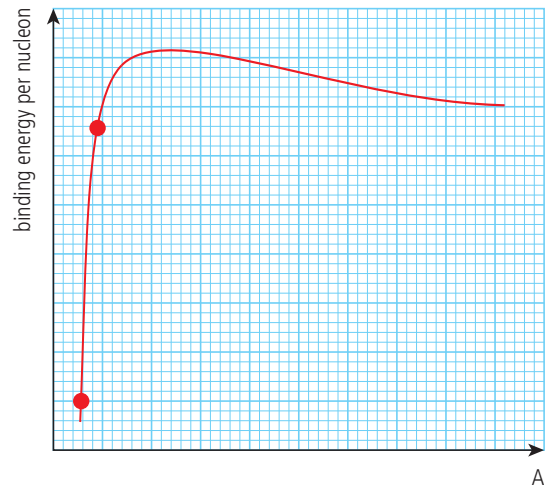

- (ii) Nuclear force is very short range, so to fuse, nuclei must get very close. But nuclei are positive, so repel each other.



To get them close they must move very fast. This can be achieved if the temperature is high.

To increase the number of collisions, the density of nuclei should be high. This is achieved by increasing pressure.

- 3 (a) (i) Fission is when a large nucleus splits into two smaller ones of roughly equal size.



Radioactive decay is when the nucleus emits a small particle (α, β, γ)



Calculate how many neutrons form the change in A:

$$235 + 1 = 90 + 142 + 4$$

- (iii) During beta decay a neutron \rightarrow proton so the number of nucleons is unchanged but the number of protons increases by 1.

A is unchanged, $Z \rightarrow Z + 1$

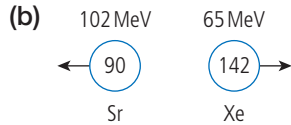

- (i) Sr has KE = 102 MeV. This is $102 \times 10^6 \times 1.6 \times 10^{-19} \text{ J}$
 $= 1.63 \times 10^{-11} \text{ J}$

mass of Sr = 90 \times mass of nucleon
 $= 90 \times 1.7 \times 10^{-27} \text{ kg}$ (approximately)
 $= 1.53 \times 10^{-25} \text{ kg}$

$$KE = \frac{1}{2}mv^2 \text{ so } v = \sqrt{\frac{2KE}{m}}$$

$$= 1.46 \times 10^7 \text{ ms}^{-1}$$

momentum = mass \times velocity
 $= 2.2 \times 10^{-18} \text{ Ns}$

- (ii) Momentum of two parts is not the same because the four neutrons will also have momentum.

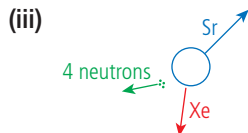

Since we don't know which way the neutrons go it is difficult to say which of the arrows should be biggest or their exact direction.

The way shown is with the neutrons on the side of the Xe.

- (c) (i) Energy released = 198 MeV
 $= 198 \times 10^6 \times 1.6 \times 10^{-19}$
 $= 3.17 \times 10^{-11} \text{ J}$
 25% of this = $7.9 \times 10^{-12} \text{ J}$

- (ii) $Q = mc\Delta T = 0.25 \times 4200 \times 80$
 $= 8.4 \times 10^4 \text{ J}$

- (iii) The number of fissions to heat the water = $\frac{8.4 \times 10^4}{7.9 \times 10^{-12}} = 1.1 \times 10^{16}$ fissions
 Each nucleus has mass $3.9 \times 10^{-25} \text{ kg}$

So mass required
 $= 1.1 \times 10^{16} \times 3.9 \times 10^{-25}$
 $= 4.1 \times 10^{-9} \text{ kg}$

- 4 (a) (i) A nucleon is a proton or neutron; these are the particles that make up the nucleus.
 (ii) Nuclear binding energy is the energy required to pull a nucleus apart or the energy released when it is formed from its constituent nucleons.

(b) and (c)

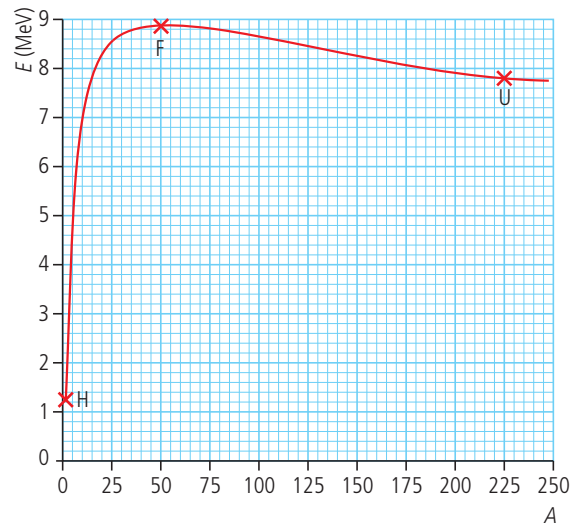

- (d) $BE = (\text{mass of parts} - \text{mass of nucleus})c^2$
 If mass is in u then can convert to MeV by multiplying by 931.5 MeV
 ${}^3_2\text{He}$ has 2 protons and 1 neutron
 $BE = [(1.00867 + 2 \times 1.00728) - 3.01603] \times 931.5 \text{ MeV}$
 $= 0.0072 \times 931.5 = 6.7 \text{ MeV}$
 $BE/\text{nucleon} = \frac{6.7}{3} = 2.2 \text{ MeV}$
- (e) ${}^2_1\text{H} + {}^2_1\text{H} \rightarrow {}^3_2\text{He} + {}^1_0\text{n}$
 (i) This is a fusion reaction.
 (ii) When two small nuclei fuse the binding energy increases. This means energy must be released.

5

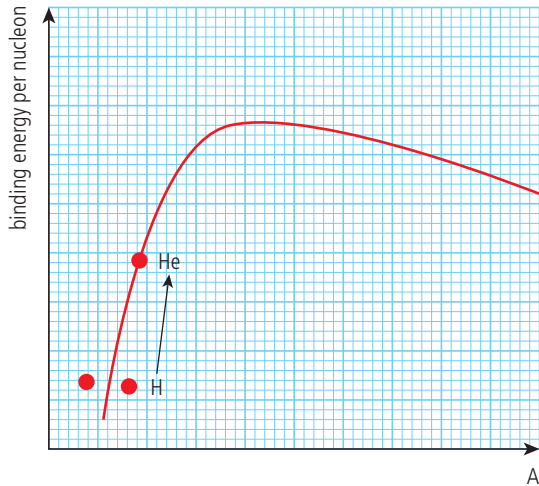

(a) The de Broglie hypothesis states that all particles have a wave associated with them. This wave gives the probability of finding the particle: its wavelength is related to the momentum of the particle by the formula $\lambda = \frac{h}{p}$ where h = Planck constant.

(b) (i) Gain is $\text{KE} = eV = 850 \text{ eV}$

or in joules

$$850 \times 1.6 \times 10^{-19} = 1.4 \times 10^{-16} \text{ J}$$

(ii) $\text{KE} = \frac{1}{2}mv^2$ so $v = \sqrt{\frac{2\text{KE}}{m}}$ × momentum,

$$\begin{aligned} p &= mv = m \sqrt{\frac{2\text{KE}}{m}} = \sqrt{2m \times \text{KE}} \\ &= \sqrt{(2 \times 9.1 \times 10^{-31} \times 1.4 \times 10^{-16})} \\ &= 1.6 \times 10^{-23} \text{ N s} \end{aligned}$$

This is in the data book.

You need to know what is in the data book in case you need to use a value.

(iii) $\lambda = \frac{h}{p} = \frac{6.6 \times 10^{-34}}{1.6 \times 10^{-23}} = 4.1 \times 10^{-11} \text{ m}$

6 (a) An electron can move from ground state to a higher energy level if

$$n = 3 \text{ _____ } -1.51 \text{ eV}$$

$$n = 2 \text{ _____ } -3.40 \text{ eV}$$

$$n = 1 \text{ _____ } -13.68 \text{ eV}$$

1. It absorbs a photon.
2. It gains energy as the gas is heated.

(b) (i) Photon energy $= hf = \frac{hc}{\lambda}$

$$= \frac{6.63 \times 10^{-34} \times 3 \times 10^8}{658 \times 10^{-9}} = 3.02 \times 10^{-19} \text{ J}$$

$$= \frac{3.02 \times 10^{-19}}{1.6 \times 10^{-19}} = 1.89 \text{ eV}$$

(ii) A transition from $n = 2 \rightarrow n = 3$ is equal to 1.89 eV so light of this wavelength will excite electrons from $n = 2 \rightarrow n = 3$ and therefore be absorbed.

(iii) The Bohr model has the electrons orbiting the nucleus in circular orbits. The Schrödinger model has the position of the electrons defined by a wave function resulting in electron probability distributions that are not circular. The Schrödinger model predicts that different energy changes have different probabilities; the Bohr model does not.

7 (a) According to the wave model the energy in the wave is related to the amplitude, not the frequency. This means that the KE of photoelectrons should be dependent on the intensity.

However KE is dependent on frequency, not intensity.

This can be explained if we consider light to be made up of photons. Each photon has energy $= hf$.

A photoelectron is emitted when the atom absorbs a photon so the KE of a photoelectron is related to f .

Intensity is related to the number of photons, so increased intensity increases the number of photoelectrons, not their KE.

(b) (i) From x intercept, threshold frequency $= 3.8 \times 10^{14} \text{ Hz}$

(ii) From gradient, Planck constant $= \frac{(4 - 1) \times 1.6 \times 10^{-19}}{(13.5 - 6) \times 10^{14}} = 6.4 \times 10^{-34} \text{ Js}$

(iii) Work function = y intercept = 1.5 eV

(c)

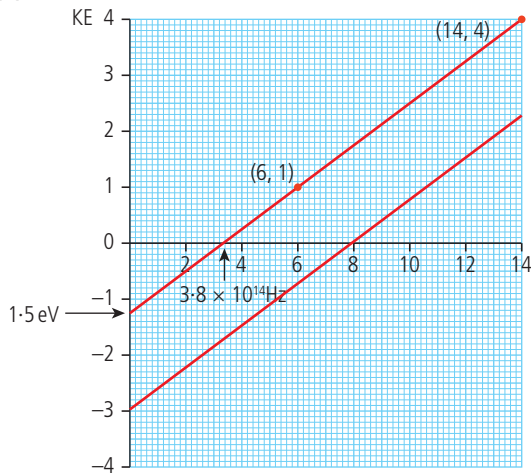

$$KE = hf - \phi$$

$$y = mx + c$$

$$\text{gradient} = h$$

$$y \text{ intercept} = -\phi$$

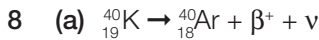

The proton number has gone down by 1
but the nucleon number is
constant $\rightarrow p^+ \rightarrow n^0 + \beta^+ + \nu$

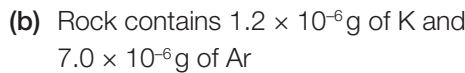

Originally all of this was K so the original
amount of K = $(7.0 + 1.2) \times 10^{-6}$
= 8.2×10^{-6} g

(c) (i) $\lambda = \frac{\ln 2}{t_{1/2}} = \frac{\ln 2}{1.3 \times 10^9} = 5.3 \times 10^{-10} \text{ year}^{-1}$

(ii) $N_0 = 8.2 \times 10^{-6}$ g

$$N = 1.2 \times 10^{-6} \text{ g}$$

$$N = N_0 e^{-\lambda t}$$

$$t = \frac{-1}{\lambda} \ln \frac{N}{N_0} = \frac{1}{\lambda} \ln \left(\frac{N_0}{N} \right)$$

$$t = \frac{1}{5.3 \times 10^{-10}} \times \ln \frac{8.2}{1.2}$$

$$= 3.6 \times 10^9 \text{ years}$$



This is due to magnetic force = Bqv

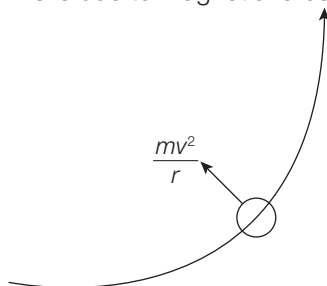

$$\text{So } Bqv = \frac{mv^2}{r}$$

$$\Rightarrow r = \frac{mv}{Bq} \Rightarrow r \propto m$$

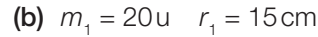

$$\text{If } r \propto m \text{ then } \frac{m_1}{m_2} = \frac{r_1}{r}$$

$$r_2 = 16.5 \text{ cm}$$

$$\frac{20 \text{ u}}{m_2} = \frac{15}{16.5}$$

$$m_2 = 22 \text{ u}$$



This would be given; you are not expected
to remember these numbers.

so 20u nucleus has 10p, 10n

22u nucleus has 10p, 12n

(They are isotopes.)

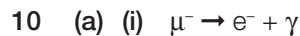

An electron is a lepton and has an
electron lepton number 1; the μ is a
muon with muon lepton number 2.
These don't balance.

Alternatively according to the standard
model leptons do not interact across
generations.

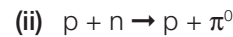

p and n are baryons so have baryon
number 1.

π^0 is a meson so has baryon number 0

\rightarrow baryon number not conserved



In this example the charge doesn't
balance.

Charge on left = +1

Charge on right = +1 - 1 = 0

Also baryon number doesn't balance
+1 \neq 0 + 0

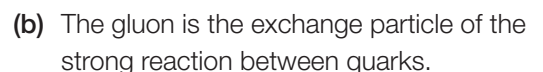

The meson is the exchange particle
between nucleons so this could also be
the answer.

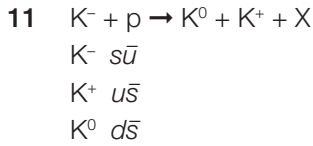

(a) The K is a hadron since it is made of two quarks.

(b) proton – duu

This you have to remember I am afraid.

(c) balancing quarks $s\bar{u} + duu \rightarrow d\bar{s} + u\bar{s} + sss$
 strange $1 \rightarrow -1-1+1+1+1$
 up $-1+1+1 \rightarrow +1$
 down $-1+1+1 \rightarrow +1$

12 (a) (i) The force between quarks is the strong force.

(ii) The exchange particle of the strong force is the gluon.

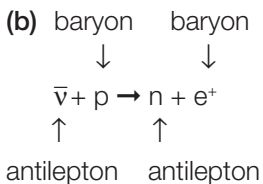

baryon number $0 + 1 = 1 + 0$ conserved

lepton number $-1 + 0 = 0 + -1$ conserved

charge $0 + 1 = 0 + 1$ conserved

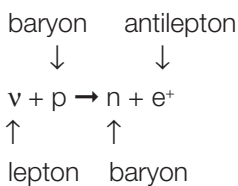

lepton number $+1 + 0 \neq 0 + -1$ not conserved

baryon number $0 + 1 = 1 + 0$ conserved

charge $0 + 1 = 0 + 1$ conserved

Second interaction will not happen because lepton number is not conserved.

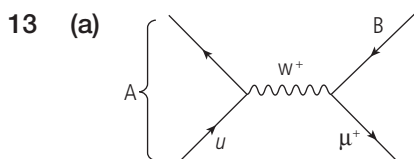

A is a π^+ meson (as stated in the question)
 B must be an antiparticle as it points back in time and the other particle on the vertex is a muon so this must be an antimuon neutrino.

(b) (i) The W boson has charge (+ or -).

(ii) The W boson has rest mass but the photon has zero rest mass.

14 (a) (i) An elementary particle cannot be split into anything smaller.

(ii) An antiparticle has the same rest mass as a particle but opposite charge.

A lepton is a group of fundamental particles that do not take part in strong interactions, e.g. an electron (-) and its antiparticle the positron (+).

(b) Coming into the interaction there is an electron and a positron: going out there are two gamma photons.

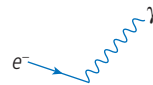

To complete the diagram each vertex must have two straight lines and a wavy line so there must be a straight line joining the vertices.

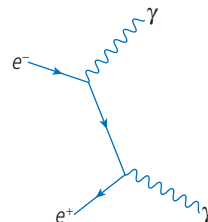

This particle must be an electron (because of the way the arrow is drawn; if drawn the other way this would be a positron) to make the lepton numbers balance. In this interaction this electron is the virtual particle.

- (c) (i) π^+ has an up and an antidown quark.
 (ii) In this interaction the baryon number is not conserved.
- (d) Two particles with spin $\frac{1}{2}$ cannot occupy the same quantum state.
- (e) Quarks have spin $\frac{1}{2}$ so must obey the Pauli exclusion principle. The introduction of colour as a property of quarks allows them to exist in baryons and mesons without violating the principle.



$$\begin{aligned} \text{Energy released} &= (\text{mass}(\text{Na}) - 11 \times \text{mass}(e)) - \\ &\quad [(\text{mass}(\text{Ne}) - 10 \times \text{mass}(e)) + \text{mass}(e)] \\ &= m(\text{Na}) - 2m_e - m(\text{Ne}) \\ &= 21.994434 - 2 \times 0.0005486 - 21.991383 \\ &= 0.00195 \\ &= 0.00195 \times 931.5 \text{ MeV} = 1.82 \text{ MeV} \end{aligned}$$

Challenge yourself

- 1 Proton number = 29 so
 Binding energy = $(29 \times \text{mass}(\text{H}) + 34 \times \text{mass}(\text{n}))$
 $- \text{mass}(\text{Cu})$
 $= 29 \times 1.0078 + 34 \times 1.00866 - 62.929599$
 (you have to look that up)
 $= 0.59104 \text{ u}$
 $= 0.59104 \times 931.5 \text{ MeV} = 551 \text{ MeV}$
 $= 551 \times 10^6 \times 1.6 \times 10^{-19} \text{ J}$
 $= 8.8 \times 10^{-11} \text{ J per atom}$
 1 mole of copper has mass 63g so 3g has
 $\frac{3}{63} \times 6 \times 10^{23}$ atoms.
 So 3g would require $8.8 \times 10^{-11} \times 2.86 \times 10^{22}$
 $= 2.5 \times 10^{12} \text{ J}$

Worked solutions

Chapter 8

Exercises

1

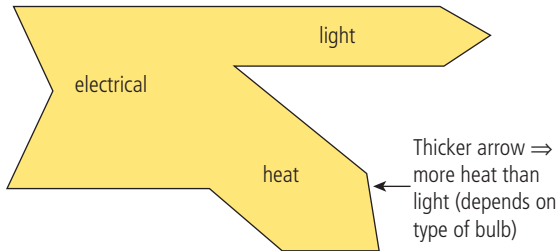

2

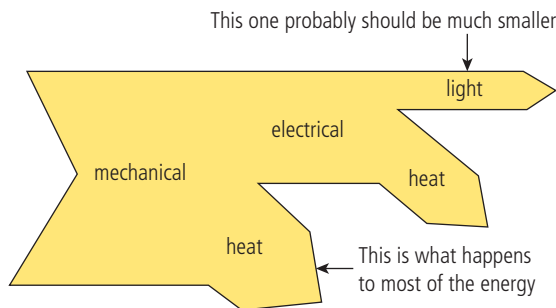

3 (a) $\text{Power} = \frac{\text{energy}}{\text{time}} \Rightarrow \text{energy} = \text{power} \times \text{time}$

$$1 \text{ day} = 24 \times 60 \times 60 = 8.64 \times 10^4 \text{ s}$$

$$\text{energy produced} = 1000 \times 10^6 \times 8.64 \times 10^4 = 8.64 \times 10^{13} \text{ J}$$

(b) $\% \text{ efficiency} = \frac{\text{energy out}}{\text{energy in}} \times 100 = 40\%$

$$\text{energy in} = \frac{\text{energy out}}{40} \times 100$$

$$= \frac{8.64 \times 10^{13}}{40} \times 100 = 2.16 \times 10^{14} \text{ J}$$

(c) $\text{Energy density} = \frac{\text{energy}}{\text{mass}}$ so

$$\text{mass} = \frac{\text{energy}}{\text{energy density}} = \frac{2.16 \times 10^{14}}{32.5 \times 10^6}$$

$$= 6.65 \times 10^6 \text{ kg}$$

(d) 1 tonne = 1000 kg; each truck contains 10^5 kg

$$\text{number of trucks} = \frac{6.6 \times 10^6}{10^5} = 66.5$$

(67 trucks needed)

4 (a) ${}^{142}_{56}\text{Ba} \rightarrow {}^{142}_{57}\text{La} + \beta^- + \bar{\nu}$

(b) Each half-life activity falls by $\frac{1}{2}$

$$\frac{1}{2} \times \frac{1}{2} \times \frac{1}{2} \times \frac{1}{2} \times \frac{1}{2} \times \frac{1}{2} \times \frac{1}{2} \times \frac{1}{2} \times \frac{1}{2} \times \frac{1}{2} \times \frac{1}{2}$$

$$= \frac{1}{1024}$$

$\Rightarrow 10$ half-lives

$$10 \times 11 \text{ months} = 110 \text{ months} = 9.2 \text{ years.}$$

5 (a) ${}^{239}\text{Pu} \rightarrow {}^{96}\text{Zr} + {}^{136}\text{Xe} + x\text{n}$

balancing nucleon number.

$$239 = 96 + 136 + x \Rightarrow x = 7$$

(b) ${}^{239}\text{Pu} \rightarrow {}^{96}\text{Zr} + {}^{136}\text{Xe} + 7\text{n}$

(c) Energy released is found from the change in mass:

$$239.052158 - [95.908275 + 135.907213 + 7 \times 1.008664] = 0.176 \text{ u}$$

$$\text{energy released} = \Delta m \times 931.5 \text{ eV} = 164 \text{ MeV}$$

(d) 1 mole Pu = 239 g \Rightarrow this contains

$$6.022 \times 10^{23} \text{ atoms}$$

(e) 1 kg is $\frac{1000}{239}$ moles

$$\text{so contains } \frac{1000}{239} \times 6.022 \times 10^{23} \text{ atoms} = 2.5 \times 10^{24} \text{ atoms}$$

(f) 164 MeV released per nucleus so $2.5 \times 10^{24} \times 164 = 4.1 \times 10^{26} \text{ MeV}$

(g) 1 eV = $1.6 \times 10^{-19} \text{ J}$ so

$$\text{energy released} = 4.1 \times 10^{26} \times 1.6 \times 10^{-19} = 6.6 \times 10^{13} \text{ J}$$

6 If 3% of the fuel is ${}^{235}\text{U}$ then of 1 kg, $\frac{3}{100}$ is ${}^{235}\text{U}$ = 0.03 kg

$$\text{energy density} = \frac{\text{energy released}}{\text{mass}} = 9 \times 10^{13} \text{ J kg}^{-1}$$

$$\Rightarrow \text{energy released} = 9 \times 10^{13} \times 0.03 = 2.7 \times 10^{12} \text{ J}$$

7 (a) energy = power \times time

$$= 10000 \times 10^3 \times 60 \times 60 = 3.6 \times 10^{10} \text{ J}$$

$$\begin{array}{ccc} \uparrow & & \uparrow \\ 10000 \text{ kW} & & 1 \text{ hour} \end{array}$$

- (b) 1 kg releases 2.7×10^{12} J
 i.e. 2.7×10^{12} J kg⁻¹
 Amount of fuel needed to release 3.6×10^{10} J
 = 1.3×10^{-2} kg = 13 g

8

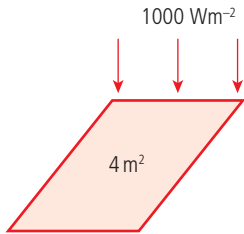

- (a) Intensity = $\frac{\text{power}}{\text{area}}$
 power = intensity \times area = $1000 \times 4 = 4$ kW

absorbed
 ↓

- (b) % efficiency = $\frac{\text{power out}}{\text{power in}} \times 100 = 50$
 ↑
 from Sun

$$\text{power out} = \frac{4 \times 50}{100} = 2 \text{ kW (2000 Js}^{-1}\text{.)}$$

- (c) In 60s, energy = $2000 \times 60 = 1.2 \times 10^5$ J
 This is given to 1 kg of water so using
 $Q = mc\Delta\theta$
 $1.2 \times 10^4 = 1 \times 4200 \times \Delta\theta = 28.6^\circ\text{C}$

9

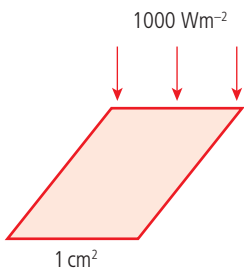

- (a) Incident power = area \times intensity
 = $1 \times 10^{-4} \times 1000 = 0.1$ W
 15% of this is absorbed $\Rightarrow \frac{15}{100} \times 0.1$
 = 1.5×10^{-2} W

- (b) $P = IV \Rightarrow 1.5 \times 10^{-2} = I \times 0.5$
 $I = 0.03$ A

- (c) 10 \times 0.5V batteries in series \rightarrow 5V

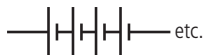

- (d) Each cell \rightarrow 0.03A so 10 batteries in parallel \rightarrow 0.3A
 (e) Each cell produces 0.015W, so to produce 100W requires $\frac{100}{0.015} = 6667$ cells

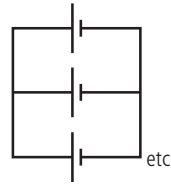

10

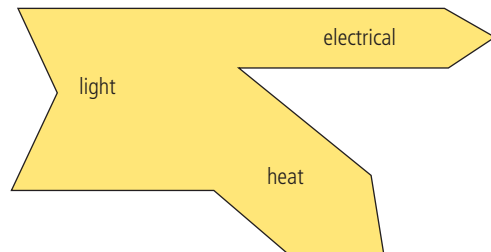

- 11 (a) Using the formula $\frac{1}{2}\rho\pi r^2 v^3 = \text{power in the wind}$

$$\text{power} = \frac{1}{2} \times 1.2 \times 3.14 \times 54^2 \times 10^3$$

$$= 5.5 \times 10^6 \text{ W} = 5.5 \text{ MW}$$

- (b) % efficiency = $\frac{\text{power out}}{\text{power in}} \times 100 = 20\%$
 power out = $\frac{20 \times 5.5}{100} = 1.1$ MW

- (c) Since power is proportional to v^3 , increasing speed by a factor 1.5 increases power by factor 1.5^3 . So power = $1.1 \times 1.5^3 = 3.7$ MW
 Note: power in the wind = $5.5 \times 1.5^3 = 18.6$ MW

- 12 (a) $\lambda = \frac{0.00289}{T} = \frac{0.00289}{500} = 5.8 \times 10^{-6}$ m

(b) $\frac{P}{A} = \sigma T^4 = 5.67 \times 10^{-8} \times 500^4$
 = 3.54×10^3 W m⁻²

(c) $P = A \sigma T^4 = 4\pi r^2 \sigma T^4$
 = $4\pi \times 0.02^2 \times 3.54 \times 10^3 = 18$ W

(d) At 1m, $I = \frac{P}{4\pi r^2} = \frac{18}{4\pi} \times 1^2 = 1.4$ W m⁻²

- 13 (a) Direct from Sun = 68 W m⁻²
 radiated from Earth = 358 W m⁻²
 convection = 105 W m⁻²
 total = 531 W m⁻²

- (b) 31 W m⁻²

- (c) Reflected = 110 W m^{-2}
 incident = 350 W m^{-2}
 albedo = $\frac{110}{350} = 0.31$
- (d) Radiated back to the Earth = 332 W m^{-2}
 radiated away 199 W m^{-2}
 total = 531 W m^{-2}
- (e) 41 W m^{-2} passes straight through
 399 W m^{-2} radiated from Earth
 $\left(\frac{41}{399}\right) \times 100\% = 10.3\%$

Practice questions

- 1 (a) Fossil fuels are continually being made on the sea floor as organisms die; however, the rate at which they are made is much slower than the rate they are used up.
- (b) (i) Nuclear waste: the process of nuclear fission produces radioactive waste, which is difficult to dispose of.
- (ii) Nuclear weapons: although nuclear fuel cannot be used directly to make bombs, the process of enrichment and raw materials are the same. A country with a nuclear power programme could theoretically be producing weapons.
- 2 (a) A solar panel is a panel containing water pipes that absorb the Sun's radiation to heat the water. This hot water can be used for showers, washing dishes, etc. A solar cell is a semiconductor device that absorbs light, converting it to electrical potential energy.

(b) (i) From the graph:

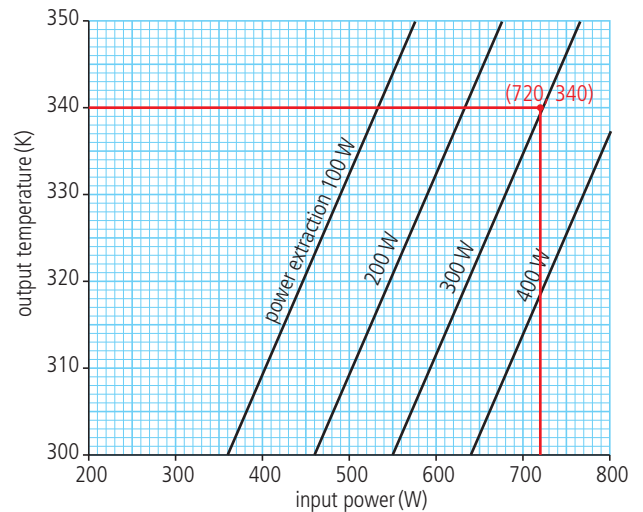

Input power = 720 W

so if intensity = 800 W m^{-2}

will need an area = $\frac{720}{800} = 0.90 \text{ m}^2$,

You don't really need to understand what is happening; you just read the graph.

- (ii) The point (500, 320) is between the 100 W and 200 W lines.

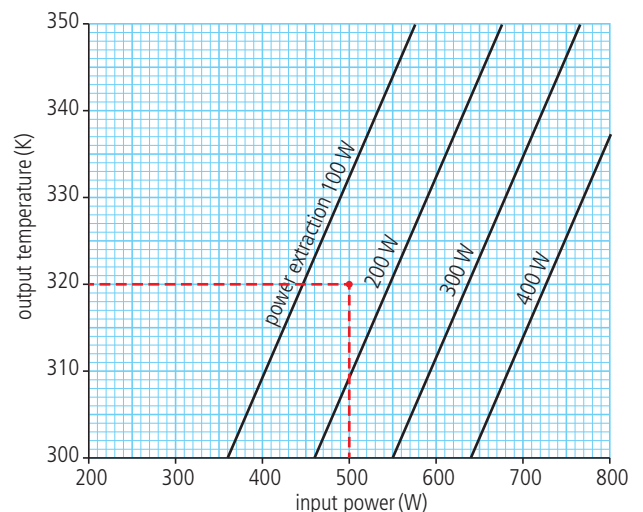

Estimate power extraction $\approx 150 \text{ W}$

efficiency = $\frac{\text{power out}}{\text{power in}} \times 100\%$

= $\frac{150}{500} \times 100\% = 30\%$

- 3 (a) Coal is burnt to produce heat; this heats water, which turns to steam; the steam turns a turbine, which turns a generator. The generator produces electricity.

Chemical energy → Heat → Kinetic energy → Electrical
 coal water turbine generator

- (b) (i) Although coal is being made from dead plants it is classified as non-renewable since it is used faster than it is produced.
 (ii) The heavy elements used in nuclear fuel are not produced on the Earth, so nuclear fuel is non-renewable.
- (c) (i) To maintain a chain reaction, neutrons must be absorbed by further nuclei. This won't happen if the neutrons are moving too quickly, so they are slowed down by the moderator.
 (ii) The chain reaction can be slowed down by preventing some of the neutrons from being absorbed by the fuel. The control rods absorb neutrons slowing down the reaction.
- (d) The main advantage is that the nuclear power station does not produce greenhouse gases. Another advantage is that there is a lot more nuclear fuel remaining in the Earth than coal.

- 4 (a) Annual energy = 120 Tj = 120×10^{12} J
 so total power = $\frac{120 \times 10^{12}}{\text{seconds in 1 year}}$
 $= \frac{120 \times 10^{12}}{60 \times 60 \times 24 \times 365} = 3.8 \text{ MW}$

If 20 turbines, each turbine has power $\frac{3.8}{20} = 0.19 \text{ MW}$

- (b) Power of turbine = $\frac{1}{2} \rho \pi r^2 v^3$
 $\Rightarrow r = \sqrt{\frac{2P}{\rho \pi v^2}} = \sqrt{\frac{2 \times 0.19 \times 10^6}{1.2 \times \pi \times 9^3}} = 12 \text{ m}$
- (c) This is an estimate since the wind speed is not always the same; the average will vary from year to year.

This calculation also doesn't take into account energy loss due to friction etc.

Also assumes all of the energy of the wind is converted to KE of turbine, this is not the case.

- (d) The main disadvantage is that turbines take up a lot of space and must be built in windy places.

It is not easy to build big towers in windy places.

- 5 (a) (i) This reaction is a fission reaction.
 (ii) The energy liberated is given to the KE of the products. Increasing the KE of the atoms results in an increased temperature.

- (b) This is best shown in a diagram.

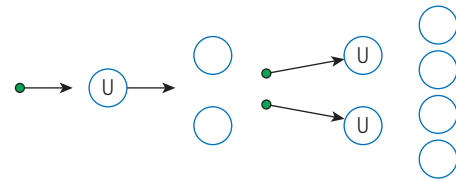

Neutrons from the first fission are absorbed by U nuclei, initiating further fissions.

- (c) (i) If the neutrons are travelling too quickly, they will pass through the U nucleus. To allow them to be absorbed they are slowed down by the moderator atoms.

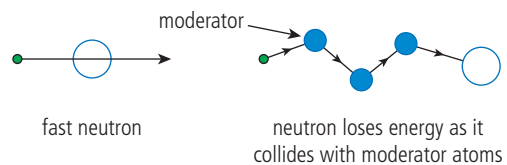

- (ii) The control rods are used to slow the reaction down. They do this by absorbing neutrons, preventing them from being absorbed by ^{235}U , leading to further fissions.
- (d) Fission of U → KE to products. This causes the temperature to increase. The hot fuel is used to turn water into steam, which drives a turbine. The turbine turns a generator that produces electricity.

- 6 (a) Only half of the Earth is exposed to the Sun, which absorbs energy as if it were a disc of area πR^2 .

So energy power absorbed = $1400\pi R^2$

If we now calculate the power received per unit area we get

$$\frac{1400\pi R^2}{\text{total area of the Earth}}$$

$$= \frac{1400\pi R^2}{4\pi R^2} = 350 \text{ W m}^{-2}$$

- (b) (i) Emissivity = power radiated by body divided by power radiated by a black body at the same temperature. From the diagram, we see that power radiated by atmosphere = $0.7\sigma T^4$.
A black body radiates σT^4 , so emissivity = 0.7.
- (ii) Power radiated per unit area = $0.7\sigma T^4 = 0.7 \times 5.67 \times 10^{-8} \times 242^4 = 136 \text{ W m}^{-2}$
- (iii) Power in = $245 + 136 = 381 \text{ W m}^{-2}$
If in equilibrium, power in = power out
 $\sigma T_E^4 = 381 \text{ W m}^{-2}$
 $T_E = \sqrt[4]{\frac{381}{5.67 \times 10^{-8}}} = 286 \text{ K}$
- (c) (i) Carbon dioxide molecules have a natural frequency in the infrared region of the electromagnetic spectrum, this means that infrared radiation will cause the molecule to oscillate and therefore be absorbed. The temperature of the Earth is such that the peak in the electromagnetic spectrum is in the infrared region so a lot of the power radiated from the Earth will be absorbed.
- (ii) The Sun has a temperature of about 6000 K so radiates in the visible region, which does not resonate with the CO_2 molecules.
- (iii) Burning fossil fuels produces CO_2 .
Plants absorb CO_2 .

- 7 (a) The power emitted per unit surface area of a black body is proportional to the fourth power of its absolute temperature

$$\frac{P}{A} = \sigma T^4$$

(b) (i) $\frac{P}{A} = \sigma T^4 = 5.67 \times 10^{-8} \times 5800^4$
 $= 6.4 \times 10^7$

$$A = 4\pi r^2 = 4\pi \times (7 \times 10^8)^2$$

$$= 6.16 \times 10^{18} \text{ m}^2$$

$$P = 6.4 \times 10^7 \times 6.16 \times 10^{18}$$

$$= 3.9 \times 10^{26} \text{ W}$$

- (ii) At a distance of $1.5 \times 10^{11} \text{ m}$, the power has spread over a larger area, so

$$\text{power per unit area} = \frac{3.9 \times 10^{26}}{4\pi \times (1.5 \times 10^{11})^2}$$

$$= 1400 \text{ W m}^{-2}$$

- (iii) If average power absorbed per unit area = 240 W m^{-2} then
power in = $240 \times \text{area}$

- (iv) power out = $\text{area} \times \sigma T^4$
power in = power out
 $\text{area} \times \sigma T^4 = 240 \times \text{area}$
 $\sigma T^4 = 240 \text{ W m}^{-2}$
 $T = 255 \text{ K}$

- (c) The radiated radiation is in the infrared region of the spectrum so is absorbed by the CO_2 in the atmosphere. After absorption, the molecules re-radiate in all directions. A proportion of this returns to the Earth; this increases the temperature. An increase in the Earth's temperature results in more power radiated until equilibrium is maintained.

- (d) Burning fossil fuels releases CO_2 into the atmosphere, this increase in CO_2 concentration leads to more absorption of infrared radiation, enhancing the greenhouse effect, resulting in more radiation being re-radiated back to Earth.

Challenge yourself

- 1 3 litres of diesel contains $3 \times 36 = 108$ MJ of energy
 50% efficient so 54 MJ is converted to useful work
 Work done against air resistance:
 work done = force \times distance
 $= F \times 100 \times 10^3$
 $= F \times 10^5$
 $F = 540$ N
 This is the force at 50 km h^{-1} , force when stopped = 0 N
 so average force = $\frac{540}{2} = 270$ N
 This gives an average acceleration
 $= \frac{F}{m}$
 $= 0.27 \text{ m s}^{-2}$
 initial velocity = $50 \text{ km h}^{-1} = 14 \text{ m s}^{-1}$
 assuming acceleration is constant $v^2 = u^2 + 2as$
 so $0 = 14^2 - 2 \times 0.27 \times s$
 $s = \frac{196}{0.54} = 363 \text{ m}$

- 2 Distance to Sun, $R = 1.5 \times 10^{11} \text{ m}$
 radius of Moon, $r = 1.7 \times 10^6 \text{ m}$
 power from Sun, $P = 3.8 \times 10^{26} \text{ W}$
 power per unit area at Moon = $\frac{P}{4\pi R^2}$
 $= 1.34 \times 10^3 \text{ W m}^{-2}$
 albedo of Moon = 0.123, so power absorbed per unit area = $(1 - 0.123) \times 1.34 \times 10^3$
 $= 1.18 \times 10^3 \text{ W m}^{-2}$
 power absorbed by the Moon = $1.18 \times 10^3 \times \pi r^2 = 1.07 \times 10^{16} \text{ W}$
 power radiated = $\epsilon \sigma AT^4$
 emissivity, $\epsilon = 0.9$
 when equilibrium reached,
 power in = power out
 $1.07 \times 10^{16} = 0.9 \times 5.67 \times 10^{-8} \times 4\pi r^2 \times T^4$
 $T^4 = 5.77 \times 10^9$
 $T = 276 \text{ K}$

Worked solutions

Chapter 9

Exercises

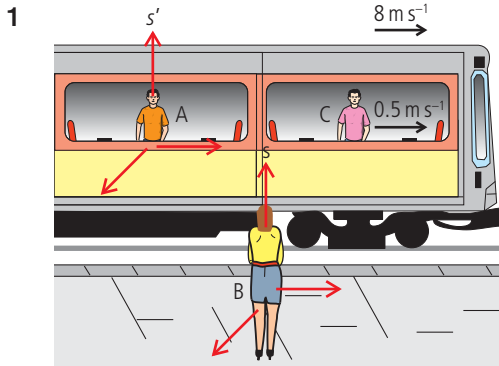

1

- (a) Velocity measured by B = $8 + 0.5 = 8.5 \text{ m s}^{-1}$
 (b) On train C walks $20 \times 0.5 = 10 \text{ m}$
 (c) Measured by B, C walks $20 \times 8.5 = 170 \text{ m}$

2

$$x = 100 \text{ m}$$

$$t = 4 \times 10^{-8} \text{ s}$$

$$v = 2 \times 10^8 \text{ m s}^{-1}$$

- (a) $\gamma = \frac{1}{\sqrt{1 - \frac{v^2}{c^2}}} = 1.34$
 (b) $x' = \gamma(x - vt)$
 $= 1.34 \times (100 - 2 \times 10^8 \times 4 \times 10^{-8})$
 $= 123.4 \text{ m}$
 $t' = \gamma\left(t - \frac{vx}{c^2}\right)$
 $= 1.34 \times \left(4 \times 10^{-8} - \frac{2 \times 10^8 \times 100}{(3 \times 10^8)^2}\right)$
 $= -2.44 \times 10^{-7} \text{ s}$

3

$$\gamma = \frac{1}{\sqrt{1 - 0.8^2}} = 1.67$$

Event 1

$$t' = \gamma\left(t - \frac{vx}{c^2}\right)$$

$$= 1.67 \times \left(4 \times 10^{-6} - \frac{0.8 \times 0}{(3 \times 10^8)^2}\right) = 6.68 \times 10^{-6} \text{ s}$$

Event 2

$$t' = 1.67 \times \left(4 \times 10^{-6} - \frac{0.8 \times 100}{(3 \times 10^8)^2}\right) = 6.22 \times 10^{-6} \text{ s}$$

4 $\gamma = \frac{1}{\sqrt{1 - 0.7^2}} = 1.4$

$$\Delta t = 2 \text{ s}$$

$$\Delta t' = \gamma \Delta t = 1.4 \times 2 = 2.8 \text{ s}$$

5 $\gamma = \frac{1}{\sqrt{1 - 0.99^2}} = 7.1$

$$\Delta t = 30 \text{ s}$$

$$\Delta t' = \gamma \Delta t = 7.1 \times 30 = 213 \text{ s}$$

- 6 a) Rocket observer uses same clock so measures proper time = 2 years

(b) $\gamma = \frac{1}{\sqrt{1 - 0.8^2}} = 1.67$

$$\Delta t' = \gamma \Delta t = 1.7 \times 2 = 3.3 \text{ years}$$

7 $\gamma = \frac{1}{\sqrt{1 - 0.7^2}} = 1.4$

$$L = \frac{L_0}{\gamma} = \frac{2}{1.4} = 1.43 \text{ m}$$

8 $\gamma = \frac{1}{\sqrt{1 - 0.99^2}} = 7.1$

(a) $d = vt = 0.99 \times 3 \times 10^8 \times 2 \times 10^{-8} = 5.94 \text{ m}$

(b) $\Delta t' = \gamma \Delta t = 7.1 \times 2 \times 10^{-8} = 14.2 \times 10^{-8} = 1.42 \times 10^{-7} \text{ s}$

(c) $d = vt' = 0.99 \times 3 \times 10^8 \times 1.42 \times 10^{-7} = 42.2 \text{ m}$

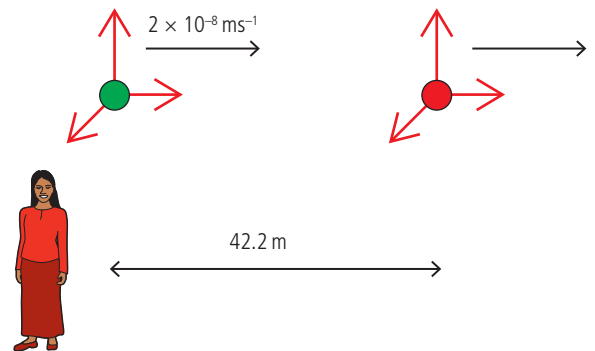

- (d) Proper time is measured in nucleus frame since the same clock can be used to measure at the start and finish.
 (e) Proper length is measured on Earth since the start and finish do not move relative to Earth.

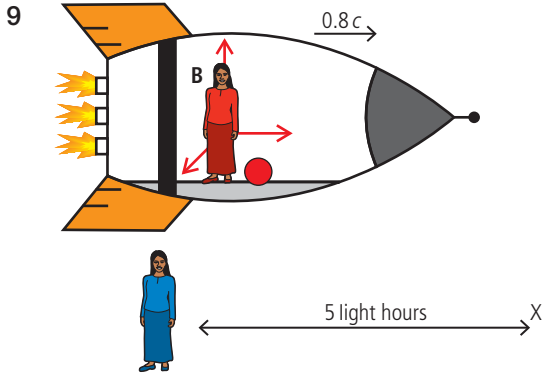

$$\gamma = \frac{1}{\sqrt{1-0.8^2}} = 1.67$$

(a) $t = \frac{d}{v} = \frac{5}{0.8} = 6.25$ hours

(b) $L = \frac{L_0}{\gamma} = \frac{5}{1.67} = 3$ light hours

(c) $t = \frac{d}{v} = \frac{3}{0.8} = 3.75$ hours

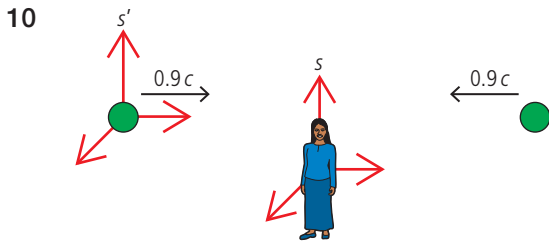

$$u' = \frac{u-v}{1-\frac{uv}{c^2}}; \quad u = -0.9c; \quad v = 0.9c$$

$$u' = \frac{-0.9c - 0.9c}{1 - \frac{-0.9 \times 0.9c^2}{c^2}} = \frac{-1.8c}{1 + 0.81} = -0.99c$$

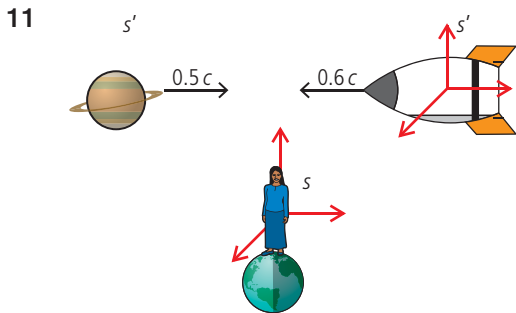

$$u' = \frac{u-v}{1-\frac{uv}{c^2}}; \quad u = 0.5c; \quad v = -0.6c$$

$$u' = \frac{0.5c - (-0.6c)}{1 - \frac{0.5 \times (-0.6)c^2}{c^2}} = \frac{1.1}{1.3}c = 0.85c$$

If meteor and ship are the other way round the answer is $-0.85c$.

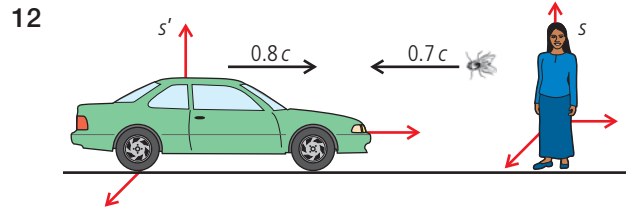

$$u' = \frac{u-v}{1-\frac{uv}{c^2}}; \quad u = -0.7c; \quad v = 0.8c$$

$$u' = \frac{-0.7c - 0.8c}{1 - \frac{-0.7c \times 0.8c}{c^2}} = -\frac{1.5}{1.56}c = -0.96c$$

13 $x = 100\text{m}$
 $t = 4 \times 10^{-8}\text{s}$
 $x' = 123.4\text{m}$
 $t' = -2.44 \times 10^{-7}\text{s}$
 $(ct)^2 - x^2 = (3 \times 10^8 \times 4 \times 10^{-8})^2 - 100^2$
 $= -9.86 \times 10^3\text{m}^2$
 $(ct')^2 - x'^2 = (3 \times 10^8 \times -2.44 \times 10^{-7})^2 - 123.4^2$
 $= -9.87 \times 10^3\text{m}^2$

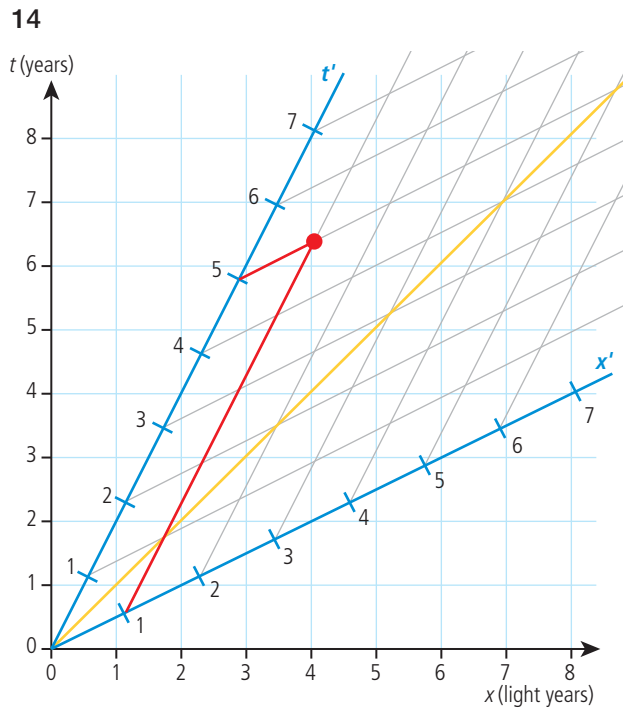

$$x = 4 \text{ light years}$$

$$t = 6.5 \text{ years}$$

$$x' = 1 \text{ light year}$$

$$t' = 5 \text{ years}$$

$$\gamma = \frac{1}{\sqrt{1-0.5^2}} = 1.15$$

$$x' = \gamma(x - vt) = 1.15 \times (4 - 0.5 \times 6.5) = 0.86 \text{ light years}$$

$$t' = \gamma \left(t - \frac{vx}{c^2} \right) = 1.15 \times (6.5 - 0.5 \times 4)$$

$$= 5.2 \text{ years}$$

$$S = (ct)^2 - (x)^2 = 4^2 - 6.5^2 = -26.3 \text{ ly}^2$$

$$S' = (ct')^2 - (x')^2 = 1^2 - 5^2 = -24 \text{ ly}^2$$

15

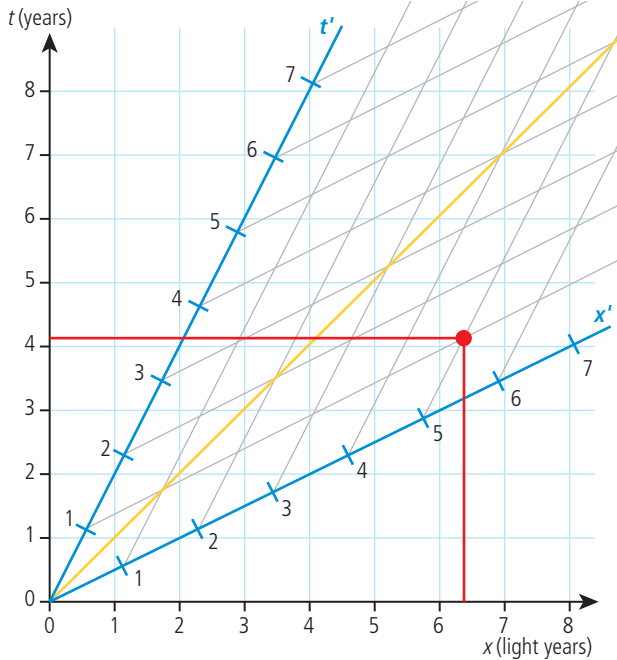

$$x' = 5 \text{ light years}$$

$$t' = 1 \text{ year}$$

$$x = 6.3 \text{ light years}$$

$$t = 4 \text{ years}$$

$$\gamma = \frac{1}{\sqrt{1 - 0.5^2}} = 1.15$$

$$x' = \gamma(x - vt) = 1.15 \times (6.3 - 0.5 \times 4) = 5$$

$$x = \left(\frac{5}{1.15} \right) + 2 = 6.3 \text{ light years}$$

$$t' = \gamma \left(t - \frac{vx}{c^2} \right) = 1.15 \times (4 - 0.5 \times 6.3) = 1 \text{ year}$$

$$t = \left(\frac{1}{1.15} \right) + 3.15 = 4.0 \text{ years}$$

$$S = (ct)^2 - (x)^2 = 4^2 - 6.3^2 = -23.7 \text{ ly}^2$$

$$S' = (ct')^2 - (x')^2 = 1^2 - 5^2 = -24 \text{ ly}^2$$

16

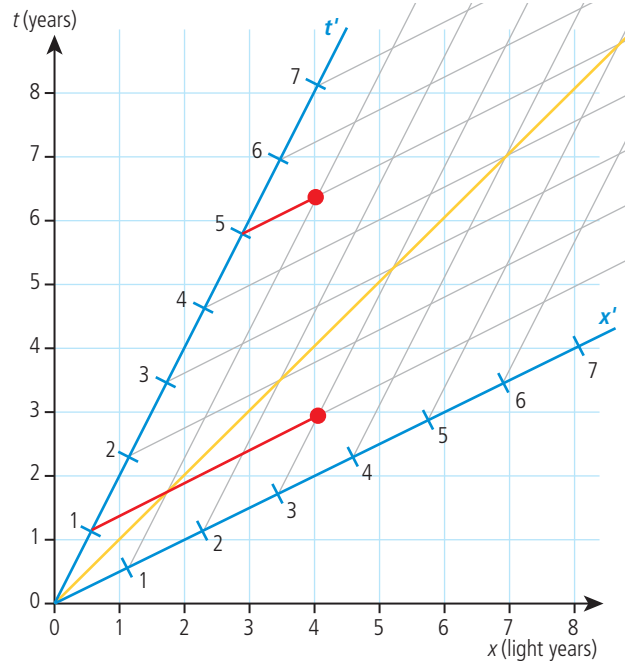

$$\Delta t' = 4 \text{ years}$$

$$\gamma = \frac{1}{\sqrt{1 - 0.5^2}} = 1.15$$

$$\Delta t' = \gamma \Delta t = 1.15 \times 3.5 = 4 \text{ years}$$

17

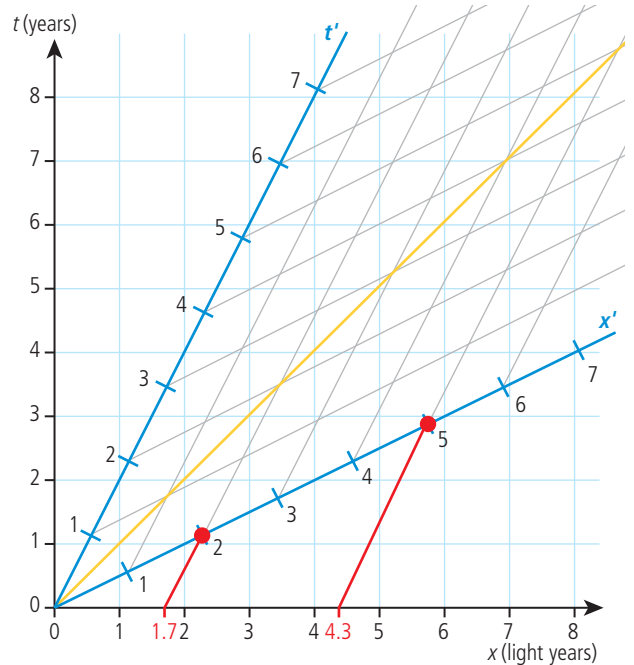

$$\text{length} = 4.3 - 1.7 = 2.6 \text{ light years}$$

$$L_0 = 3 \text{ light years}$$

$$L = \frac{L_0}{\gamma} = \frac{3}{1.15} = 2.6 \text{ light years}$$

18

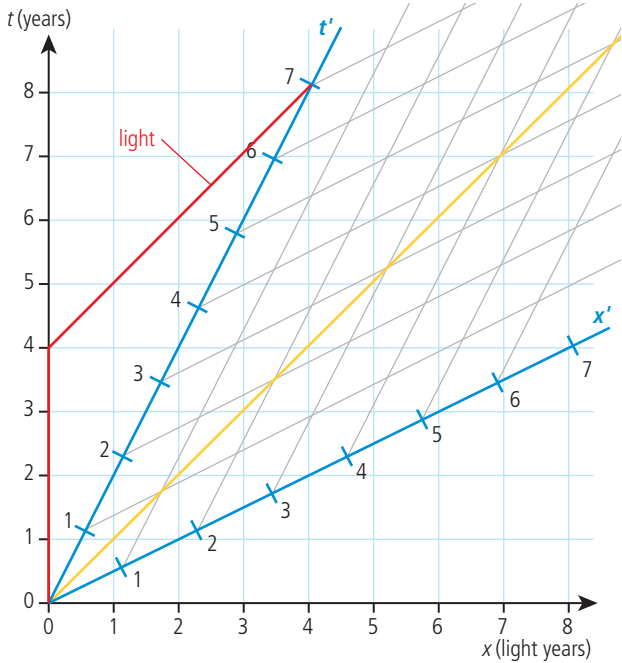

Note that the rocket is taken to be S and the Earth S'. Signal arrives on Earth (t') 7 years after the rocket launched. This is 8 years as measured on the rocket.

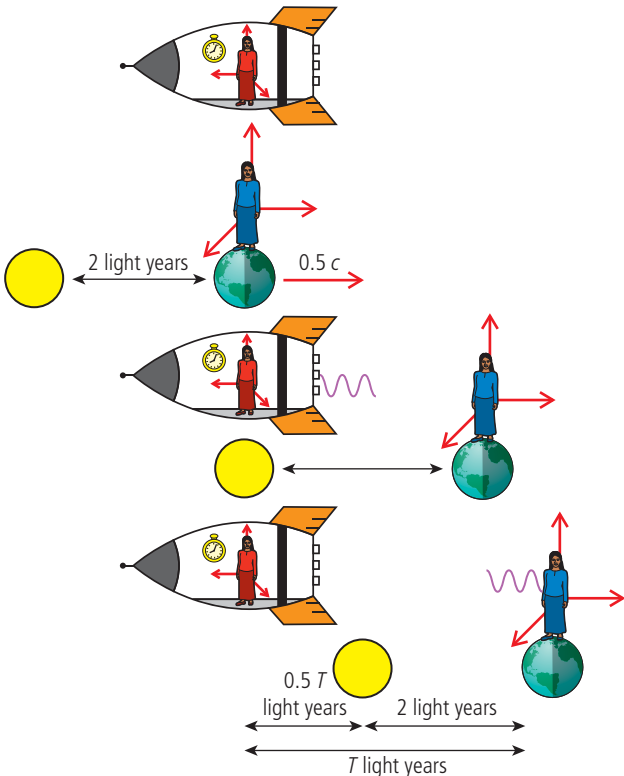

From the view of the rocket, the Earth moves with velocity $0.5c$ as shown.

$$T \text{ light years} = 0.5T \text{ light years} + 2 \text{ light years}$$

$$T = 4 \text{ years}$$

This is the time for the signal to reach Earth but the signal was sent 4 years after launch so it arrives 8 years after launch.

The Earth observer can measure both launch and arrival of signal with the same clock, so this is the proper time. $T_0 = \frac{T}{\gamma} = \frac{8}{1.15} = 7$ years after launch.

Alternative method:

When rocket has travelled 4 years measured by the rocket, the time for an Earth observer = $4 \times 1.15 = 4.6$ years

Distance travelled by the rocket in this time = 2.3 light years

Time for signal to arrive = time to point of sending + time for signal to travel back = $4.6 + 2.3 = 7$ years

This is the proper time, since it can be measured with the same clock on Earth.

Time for rocket observer = $\gamma T_0 = 7 \times 1.15 = 8$ years

Maybe you are now convinced about space time diagrams.

19

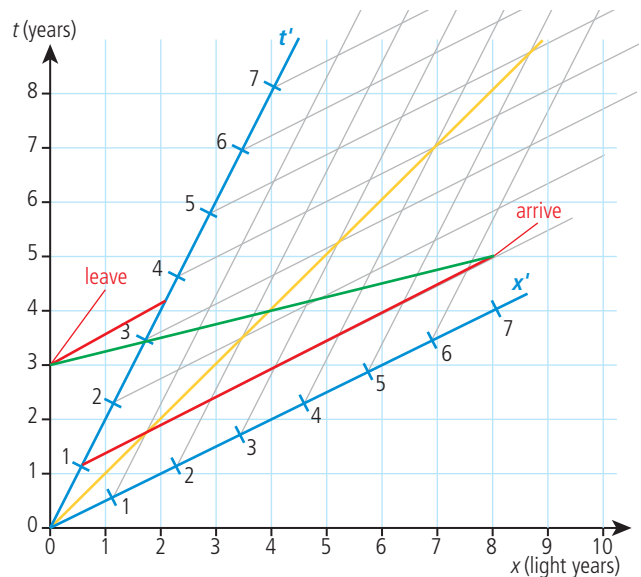

Rocket departs in June 2003 and arrives back in January 2001.

If travelling at $2c$ the rocket arrival and departure would be simultaneous.

Can't check since $\gamma = \frac{1}{\sqrt{-15}}$, which we

cannot do, even using complex numbers, since it would give a complex answer and complex time does not have a meaning.

- 20 If $v = 0.8c$

$$\gamma = \frac{1}{\sqrt{(1 - 0.8^2)}} = 1.67$$

$$m_0 = 100 \text{ MeV}c^{-2}$$

Energy of particle = rest energy + KE

$$E = \gamma m_0 c^2 = 1.67 \times 100 = 167 \text{ MeV}$$

$$\text{but } E^2 = m_0^2 c^4 + p^2 c^2$$

$$\Rightarrow p^2 c^2 = E^2 - m_0^2 c^4 = 167^2 - 100^2 = 17889$$

$$pc = \sqrt{17889} = 134 \text{ MeV}$$

$$p = 134 \text{ MeV}c^{-1}$$

or

$$\gamma M_0 v = 1.67 \times 100 \text{ MeV}c^{-2} \times 0.8c$$

$$= 134 \text{ MeV}c^{-1}$$

- 21 $M_0 = 200 \text{ MeV}c^{-2} \Rightarrow$ rest energy = 200 MeV

$$\text{KE} = 1 \text{ GeV}$$

$$\text{(a) } E = \text{rest energy} + \text{KE} = 1000 + 200 = 1200 \text{ MeV}$$

$$E^2 = m_0^2 c^4 + p^2 c^2$$

$$p^2 c^2 = E^2 - m_0^2 c^4 = 1200^2 - 200^2$$

$$\Rightarrow pc = 1183 \text{ MeV}; \quad p = 1183 \text{ MeV}c^{-1}$$

$$\text{(b) } \text{KE} = (\gamma - 1) m_0 c^2 \Rightarrow 1000 = (\gamma - 1) 200$$

$$\gamma = 6 = \frac{1}{\sqrt{1 - \frac{v^2}{c^2}}} \Rightarrow v^2 = \left(1 - \frac{1}{6^2}\right) c^2$$

$$v = 0.986 c$$

- 22 $M_0 = 200 \text{ MeV}c^{-2}$

$$\gamma = \frac{1}{\sqrt{(1 - 0.8^2)}} = 1.67$$

$$v = 0.8c$$

$$\text{(a) } \text{KE} = (\gamma - 1) m_0 c^2 = (1.67 - 1) 200 = 100.5 \text{ MeV}$$

$$\text{(b) } \text{Total energy} = \text{rest energy} + \text{KE} = 200 + 100.5 = 300.5 \text{ MeV}$$

$$\text{(c) } E^2 = m_0^2 c^4 + p^2 c^2$$

$$p^2 c^2 = E^2 - m_0^2 c^4 = 300.5^2 - 200^2$$

$$pc = 260; \quad p = 260 \text{ MeV}c^{-1}$$

$$23 \text{ (a) } E^2 = m_0^2 c^4 + p^2 c^2; \quad m_0 = 938 \text{ MeV}c^{-2}$$

$$E^2 = 938^2 + 150^2; \quad p = 150 \text{ MeV}c^{-1}$$

$$E = 950 \text{ MeV}$$

$$\text{(b) } \text{KE} = \text{total energy} - \text{rest energy} = 950 - 938 = 12 \text{ MeV}$$

$$\text{(c) } \text{Accelerating pd} = 12 \text{ MV}$$

$$\text{(d) } E = \gamma m_0 c^2 \Rightarrow \gamma = \frac{E}{m_0 c^2} = \frac{950}{938} = 1.013$$

$$\Rightarrow 1.013 = \frac{1}{\sqrt{1 - \frac{v^2}{c^2}}}$$

$$v^2 = \left(1 - \frac{1}{1.013^2}\right) c^2$$

$$v = 0.16c$$

- 24 KE of each electron = 1 MeV

$$\text{Total energy} = \text{KE} + \text{rest energy}$$

$$= 2 \times 1 + 2 \times 0.5 = 3 \text{ MeV}$$

This is 1.5 MeV each if the energy is shared equally between them.

- 25

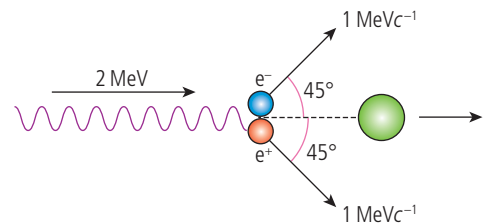

$$\text{Momentum of photon} = \frac{E}{c} = 2 \text{ MeV}c^{-1}$$

$$\text{Horizontal component of momentum after}$$

$$= 2 \times 1 \times \cos 45^\circ = 1.41 \text{ MeV}c^{-1}$$

$$\text{So momentum of nucleus}$$

$$= 2 - 1.41 = 0.59 \text{ MeV}c^{-1}$$

- 26

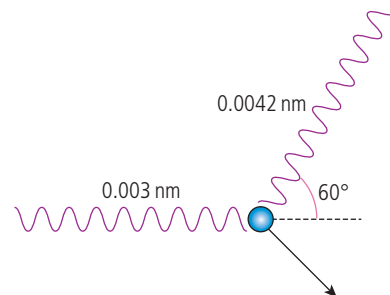

$$E_{\text{in}} = \frac{hc}{\lambda} = \frac{6.63 \times 10^{-34} \times 3 \times 10^8}{1.6 \times 10^{-19} \times 0.003 \times 10^{-9}} = 0.414 \text{ MeV}$$

$$E_{\text{out}} = \frac{hc}{\lambda} = 0.296 \text{ MeV}$$

$$\text{Energy transferred to the electron}$$

$$= 0.414 - 0.296 = 0.118 \text{ MeV}$$

27 Photon energy = 14.4 keV
 $= 14.4 \times 10^3 \times 1.6 \times 10^{-19} \text{ J} = 2.3 \times 10^{-15} \text{ J}$
 $E = hf \Rightarrow f = \frac{E}{h} = \frac{2.3 \times 10^{-15}}{6.63 \times 10^{-34}} = 3.48 \times 10^{18} \text{ Hz}$
 $\frac{\Delta f}{f} = \frac{g\Delta h}{c^2} \Rightarrow \Delta f = \frac{fg\Delta h}{c^2}$
 $= \frac{3.48 \times 10^{18} \times 9.8 \times 22.6}{(3 \times 10^8)^2}$
 $\Delta f = 8.56 \times 10^3 \text{ Hz}$

- 28 (a) The rocket is an inertial frame of reference so no different from a stationary frame; the wavelength will be the same at each end.
 (b) The rocket is accelerated; this is the same as if it were in a gravitational field, as shown:

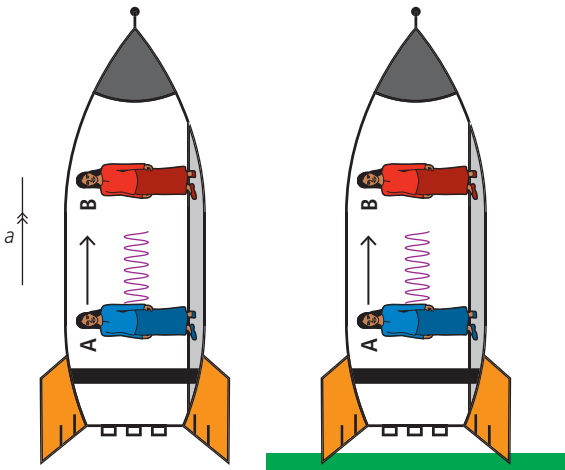

As photon goes from A to B it will lose energy and its wavelength will increase, so its frequency decreases.

29 $R_s = \frac{2GM}{C^2}$
 $R_s = \frac{2 \times 6.67 \times 10^{-11} \times 2 \times 10^{31}}{(3 \times 10^8)^2} = 29600 \text{ m}$
 $= 29.6 \text{ km.}$

30 (a) $\Delta t = \frac{\Delta t}{\sqrt{1 - \frac{R_s}{r}}} = \frac{60}{\sqrt{1 - \frac{29600}{10^9}}} = 60.0009 \text{ s}$
 (b) $\Delta t = \frac{60}{\sqrt{1 - \frac{29600}{10^5}}} = 71.5 \text{ s}$
 (c) $\Delta t = \frac{60}{\sqrt{1 - \frac{29600}{6 \times 10^4}}} = 84.3 \text{ s}$

Practice questions

- 1 (a) Proper length and time are lengths and times measured by an observer in a frame of reference that is at rest relative to the events being measured.
 (b) (i) If Miguel sees the matches light simultaneously then the light from each strike must arrive to him at the same time. But to Carmen, Miguel is moving towards B so the light from B has travelled a shorter distance, so if the lights reach Miguel at the same time, the match A must have been struck first.

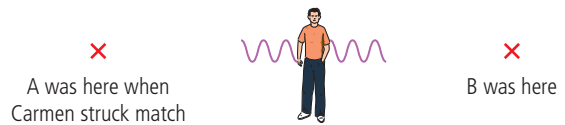

Note: This is the other way round if the events are simultaneous on the station but not on the train.

- (ii) Miguel is at rest relative to A and B so $L_0 = 20 \text{ m}$
 Carmen is moving relative to A and B so $L = \frac{L_0}{\gamma} \Rightarrow \gamma = 2$
 $\gamma = \frac{1}{\sqrt{1 - \frac{u^2}{c^2}}} \Rightarrow \frac{1}{\gamma^2} = 1 - \frac{u^2}{c^2}$
 $\Rightarrow u = c \sqrt{1 - \frac{1}{\gamma^2}}$
 $u = 0.87c$
 (iii) The measurements are different because they are in different frames of reference; there is no right and wrong.

2 (a)

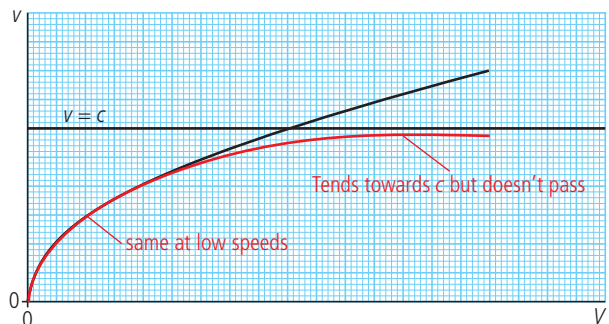

- (b) According to the principles of special relativity it is not possible for the electron to exceed the speed of light. This is because the mass tends to go as velocity approaches the speed of light so to reach c would require ∞ force.

At low speeds there is, however, no difference between classical and relativistic predictions.

- (c) $pd = 1.5 \times 10^6 \text{ V}$

\Rightarrow gain in KE of electrons = 1.5 MeV

velocity = $0.97c$

- (i) Relativistic mass = γm_0
 where $\gamma = \frac{1}{\sqrt{1 - \frac{v^2}{c^2}}} = \frac{1}{\sqrt{1 - \frac{0.97^2 c^2}{c^2}}} = 4.1$

Rest mass of $e^- = 0.5 \text{ MeV} c^{-2}$

\Rightarrow Relativistic mass = 4.1×0.5
 = $2.1 \text{ MeV} c^{-2}$

Easiest to work in $\text{MeV} c^{-2}$

- (ii) Total $E = mc^2 = 2.1 \text{ MeV}$

- 3 (a) An inertial frame of reference is a coordinate system covered in clocks within which Newton's laws of motion are obeyed.

In other words not accelerating.

- (b)  $T_0 = \frac{2D}{c} \left(\frac{\text{distance}}{\text{velocity}} \right)$

- (c) (i)

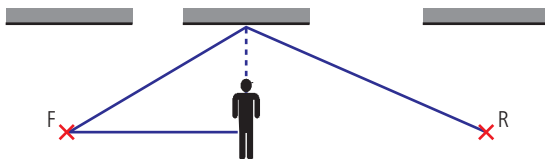

- (ii) Distance $F-R = vT$

- (iii) From Pythagoras:

path length = $2 \times \sqrt{\left(D^2 + \frac{v^2 T^2}{4}\right)}$

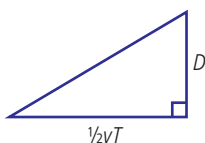

- (iv) We know that observer E sees the light travel from F to R in time T . Since the speed of light is the same for all inertial observers this must be a distance cT .

$$\text{so } cT_0 = 2\sqrt{D^2 + \left(\frac{vT}{2}\right)^2}$$

$$\text{but } D = \frac{cT_0}{2} \text{ so } cT = 2\sqrt{\left(\frac{cT_0}{2}\right)^2 + \left(\frac{vT}{2}\right)^2}$$

$$\text{squaring } \Rightarrow c^2 T^2 = 4\left(\frac{c^2 T_0^2}{4} + \frac{v^2 T^2}{4}\right)$$

$$c^2 T^2 = c^2 T_0^2 + v^2 T^2$$

$$(c^2 - v^2)T^2 = c^2 T_0^2 \Rightarrow T_0^2 = \left(\frac{c^2 - v^2}{c^2}\right) T^2$$

$$T_0 = \left(1 - \frac{v^2}{c^2}\right) T^2$$

$$\Rightarrow T = \frac{T_0}{\sqrt{1 - \frac{v^2}{c^2}}}$$

- 4 (a) According to special relativity, energy and mass are equivalent ($E = mc^2$) so the mass of a body at rest can be converted into energy; this is the rest mass energy.

When accelerated, a body gains KE so it now has KE + rest mass energy; this is the total energy of the body.

- (b) Total energy of β particle = 2.51 MeV

β particle is an electron so has rest mass = $0.511 \text{ MeV} c^{-2}$

Total energy = $mc^2 = \gamma m_0 c^2$

$$\Rightarrow 2.51 = \gamma \times 0.511 \Rightarrow \gamma = 4.91$$

- (c) (i) If $\gamma = 4.91$ then

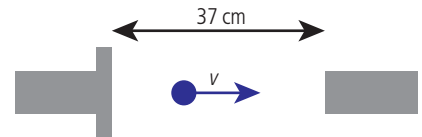

can find speed of β particles using

$$\gamma = \frac{1}{\sqrt{1 - \frac{v^2}{c^2}}} \Rightarrow v = c \sqrt{\left(1 - \frac{1}{\gamma^2}\right)}$$

$$v = c \sqrt{\left(1 - \frac{1}{4.91^2}\right)} = 0.979c$$

- (ii) $0.979c = 0.979 \times 3 \times 10^8$

$$= 2.94 \times 10^8 \text{ ms}^{-1}$$

distance = 0.37 m

$$t = \frac{d}{v} = \frac{0.37}{2.94 \times 10^8} = 1.258 \text{ ns}$$

- (d) (i) From the β particle's frame of reference, the detector and source are moving.

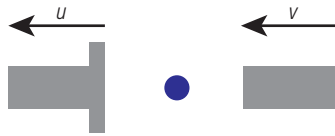

(ii) The speed of the detector is the same as the speed of the β particle as measured in the laboratory reference frame.

$$v = 2.94 \times 10^8 \text{ m s}^{-1}$$

(iii) In the frame of reference of the β particle the distance from source to detector is contracted

$$\text{so } L = \frac{L_0}{\gamma}$$

$L_0 = 37 \text{ cm}$, the distance measured at rest relative to the detector

$$L = \frac{37}{4.91} = 7.5 \text{ cm}$$

5 (a) Postulate 1. The laws of physics are the same for all inertial observers.

Postulate 2. The speed of light in a vacuum is the same as measured by all inertial observers.

(b) (i)

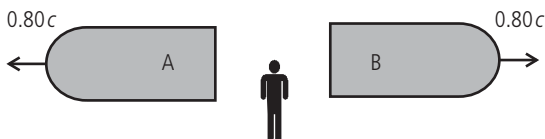

Each spacecraft moves away from the observer at $0.8c$; this is not greater than c .

To find out how fast they move from each other, we would have to determine the velocity of A relative to B.

(ii) velocity transform is $u' = \frac{u-v}{1-\frac{uv}{c^2}}$

Let us measure the velocity of A from the reference frame of B

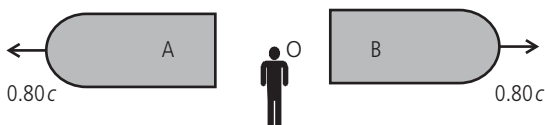

u – velocity of A measured by $O = -0.8c$

v – velocity of B's reference frame relative to $O = 0.8c$

$$u' = \frac{0.8c + 0.8c}{1 - \frac{0.8c \times 0.8c}{c^2}} = \frac{1.6c}{1 + 0.64}$$

$$u' = 0.98c$$

6 (a) A reference frame is a coordinate system covered in clocks. It is used by an observer to measure the time and position of an event.

(b) Classically the light coming from the lamp will have velocity $= c - v$

like throwing something off the back of a truck.

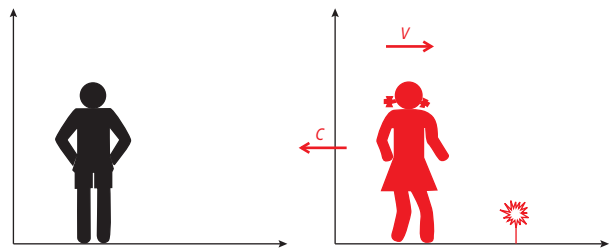

(c) According to Maxwell's theory the speed of light doesn't depend on the velocity of the source so velocity $= c$

(d) $u' = \frac{u-v}{1-\frac{uv}{c^2}}$; substitute $u = c$ to get

$$u' = \frac{c-v}{1-\frac{cv}{c^2}} = \frac{c-v}{1-\frac{v}{c}} = \frac{c(c-v)}{c-v} = c$$

(e) (i) Proper time is the time as measured by an observer at rest relative to the event being timed.

$$(ii) T = \gamma T_0 \quad T_0 = 1.5 \mu\text{s}$$

$$\gamma = 2 \quad T = 3.0 \mu\text{s}$$

$$\gamma = \frac{T_0}{\sqrt{1-\frac{v^2}{c^2}}} \Rightarrow \frac{1}{\gamma^2} = 1 - \frac{v^2}{c^2}$$

$$\Rightarrow v = c \sqrt{1 - \frac{1}{\gamma^2}}$$

$$v = 0.87c$$

7 (a) (i) The time to travel 52 light years at a speed of $0.8c = \frac{52}{0.8} = 65$ years

(ii) The Earth observer measures the proper distance between Earth and the planet distance measured by Amanda

$$= \frac{L_0}{\gamma} = \frac{52}{\left(\frac{5}{3}\right)} = 31.2 \text{ light years}$$

- (iii) Time to reach planet according to spacecraft is

$$\frac{31.2 \text{ light years}}{0.80c} = 39 \text{ years,}$$

so Amanda is $20 + 39 = 59$ years old.

- (b) If we take Amanda's frame of reference, Earth is moving away so the signal has to travel an extra distance to get to Earth.

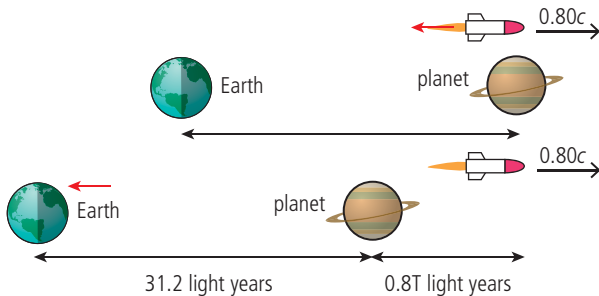

In the time T for the signal to get to Earth the signal travelled $31.2 + 0.8T$ light years

The signal travelled at the speed of light so in T years light will have travelled T light years

$$T = 31.2 + 0.8T = 156 \text{ years}$$

- 8 (a) The Schwarzschild radius is the minimum distance from the centre of a black hole that light can escape.

(b)
$$R_s = \frac{2GM}{c^2} = \frac{2 \times 6.7 \times 10^{-11} \times 2 \times 10^{31}}{(3 \times 10^8)^2}$$

$$= 3 \times 10^4 \text{ m}$$

- (c) (i) Clocks tick slowly near to large masses so the oscillator near the large mass will have a lower frequency than an identical oscillator on the space station.

- (ii) The time dilation equation is

$$\Delta t = \frac{\Delta t_0}{\sqrt{1 - \frac{R_s}{r}}}$$

$$\frac{R_s}{r} = 1 - \left(\frac{\Delta t_0}{\Delta t} \right)^2$$

where $\Delta t_0 = 1$ hour and $\Delta t = 10$ hours

$$\frac{R_s}{r} = 0.99$$

$r = 1.01 R_s$, which means they would be $0.01 R_s$ from the event horizon.

- 9 (a) Particle A has only rest energy; KE = 0
 Particle B has rest energy + KE

- (b) (i) Using the relativistic velocity transformation

$$u'_x = \frac{u_x - v}{1 - \frac{u_x v}{c^2}}$$

u_x – velocity of body measured in S

u'_x – velocity of body measured in S'

v – relative velocity of two frames of reference

$$u'_x = \frac{0.96c + 0.96c}{1 + \frac{0.96c \times 0.96c}{c^2}} = 0.999c$$

- (ii) Total energy = $\gamma m_0 c^2$ where

$$\text{where } \gamma = \frac{1}{\sqrt{1 - \frac{v^2}{c^2}}} = \frac{1}{\sqrt{1 - \frac{(0.96c)^2}{c^2}}} = 3.57$$

The rest energy of a proton = 938 MeV

so total energy of proton in question

$$= 3.57 \times 938 = 3.35 \text{ GeV}$$

- (c) (i) Total energy before collision

$$= 2 \times 3.35 = 6.7 \text{ GeV}$$

After collision energy = energy of proton

+ energy of neutron + energy of pion

If pion has 502 GeV (0.502 MeV) then the proton and neutron will have

$$6.7 - 0.502 = 6.2 \text{ GeV}$$

- (ii) using $E^2 = m_0^2 c^4 + p^2 c^2$

where E = total pion energy

pc = pion momentum

$m_0 c^2$ = pion rest energy

$$p^2 c^2 = 502^2 - 140^2 = 232\,400$$

$$p = 482 \text{ MeV c}^{-1}$$

- (d) The proton must have momentum in the $-x$ direction to balance the proton and pion plus momentum in the $-y$ direction to balance the y momentum of the neutron.

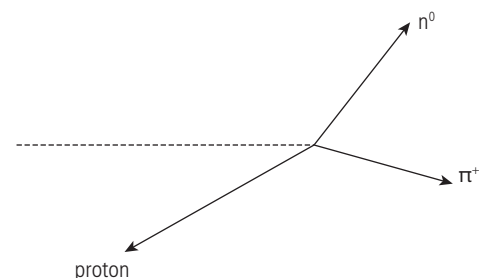

Worked solutions

Chapter 10

Exercises

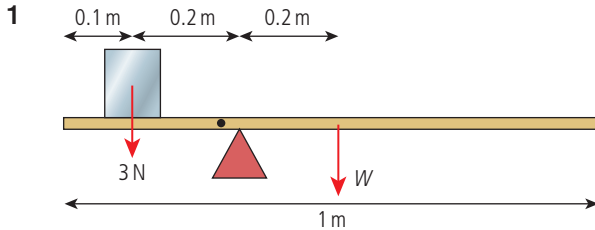

Clockwise: $W \times 20$

Anticlockwise: 3×20

$$W \times 20 = 3 \times 20$$

$$W = 3 \text{ N}$$

$$\text{Mass} = 300 \text{ g}$$

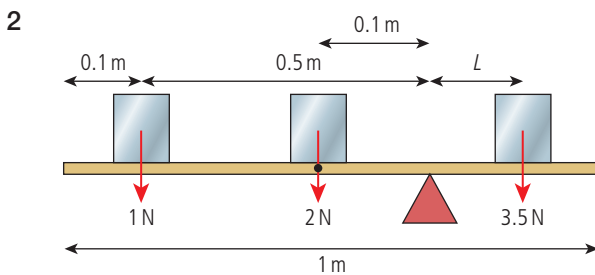

Clockwise: $3.5 \times L$

Anticlockwise: $1 \times 0.5 + 2 \times 0.1 = 0.7 \text{ Nm}$

$$3.5 \times L = 0.7$$

$$L = 0.2 \text{ m}$$

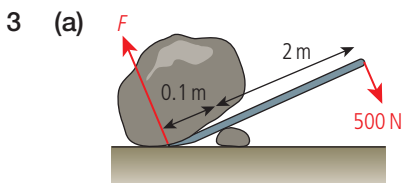

F marked is the force on the rock.

Force on crowbar acts in the opposite direction so turns the bar anticlockwise.

$$500 \times 2 = F \times 0.1$$

$$F = 10\,000 \text{ N}$$

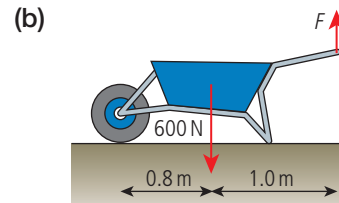

$$F \times 1.8 = 600 \times 0.8$$

$$F = 267 \text{ N}$$

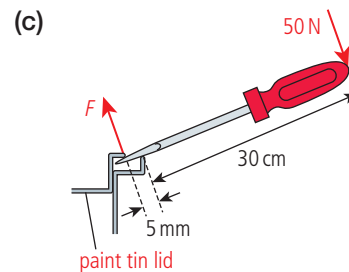

Again F is force acting on the lid; force on the screwdriver is opposite.

$$50 \times 30 = F \times 0.5$$

$$F = 3000 \text{ N}$$

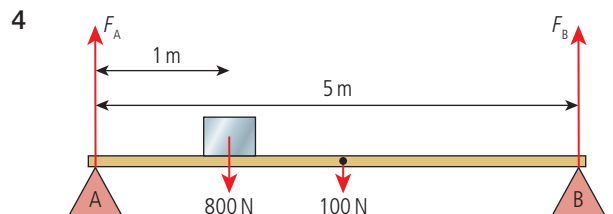

Take torques about B

Clockwise: $F_A \times 5$

Anticlockwise: $800 \times 4 + 100 \times 2.5$

$$F_A = 690 \text{ N}$$

Vertical forces balance so $F_A + F_B = 900 \text{ N}$

$$F_B = 210 \text{ N}$$

5

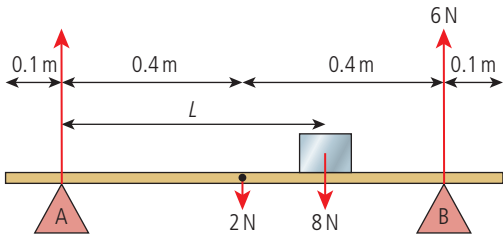

Drawn at breaking point

Take torques about A

Clockwise: $2 \times 0.4 + 8 \times L$

Anticlockwise: $6 \times 0.8 = 4.8 \text{ Nm}$

$4.8 = 0.8 + 8 \times L$

$L = 0.5 \text{ m}$

Moved 0.1 m

6

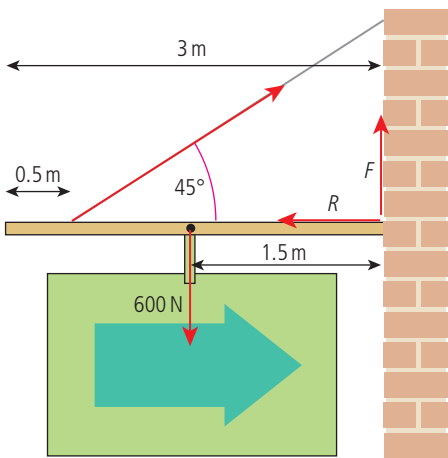

(a) Take torques about the wall

$$T \times \sin 45^\circ \times 2.5 = 600 \times 1.5$$

$$T = \frac{900}{2.5 \times \sin 45^\circ}$$

$$T = 509 \text{ N}$$

(b) Horizontal forces are balanced

$$R = \text{horizontal component of } T \\ = 509 \times \cos 45^\circ = 360 \text{ N}$$

(c) Vertical forces are balanced

$$T \times \sin 45^\circ + F = 600$$

$$F = 240 \text{ N}$$

7

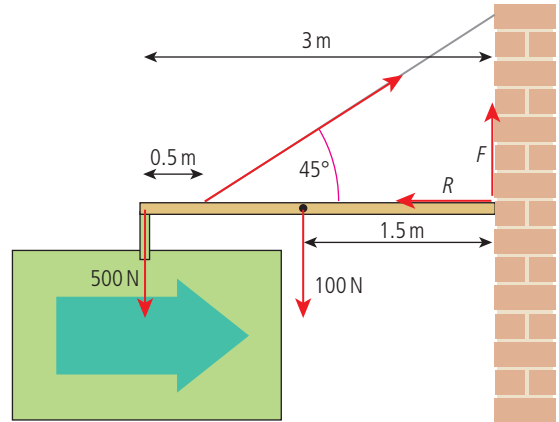

(a) Take torques about the wall

$$T \times \sin 45^\circ \times 2.5 = 500 \times 3 + 100 \times 1.5$$

$$T = \frac{1650}{2.5 \times \sin 45^\circ}$$

$$T = 933 \text{ N}$$

(b) Horizontal forces are balanced

$$R = \text{horizontal component of } T \\ = 933 \cos 45^\circ$$

$$R = 660 \text{ N}$$

(c) Vertical forces are balanced

$$500 + 100 = 933 \times \sin 45^\circ + F$$

$$F = 600 - 660$$

$$F = -60 \text{ N (downwards)}$$

8

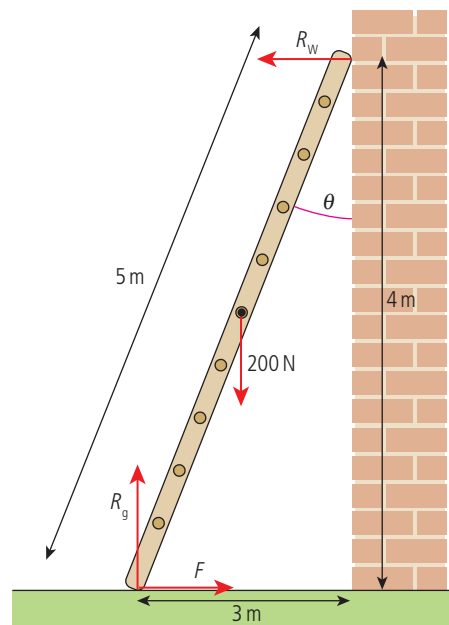

It's a 3-4-5 triangle so height = 4 m

Vertical forces are balanced, $R_g = 200 \text{ N}$

Take torques about the top
 Clockwise: $R_g \times 3 = 200 \times 3 = 600 \text{ Nm}$
 Anticlockwise: $F \times 4 + 200 \times 1.5$
 $600 = 4F + 300$
 $F = 75 \text{ N}$

9

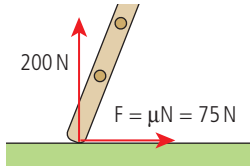

Ladder is about to slip so
 $\mu \times N = 75$
 $\mu \times 200 = 75$
 $\mu = 0.375$

10

$\omega_i = 6 \text{ rad s}^{-1}$
 $\alpha = 2 \text{ rad s}^{-2}$
 $t = 5 \text{ s}$

(a) $a = \frac{(v-u)}{t}$
 $v = u + at$

$\omega_f = 6 + 2 \times 5 = 16 \text{ rad s}^{-1}$

(b) $s = \frac{(v+u)t}{2}$

$\theta = \frac{(16+6) \times 5}{2} = 55 \text{ rad}$

Number of revolutions = $\frac{55}{2\pi} = 8.75$

11

$\theta = 2\pi$

$\omega_i = 5 \times 2\pi \text{ rad s}^{-1}$

$\omega_f = 0 \text{ rad s}^{-1}$

(a) $v^2 = u^2 + 2as$

$a = \frac{(v^2 + u^2)}{2s}$

$\alpha = \frac{(0 - (10\pi)^2)}{(2 \times 2\pi)}$

$\alpha = -25\pi = -78.54 \text{ rad s}^{-2}$

(b) $s = \frac{(u+v)t}{2}$

$t = \frac{2s}{(u+v)} = \frac{2 \times 2\pi}{10\pi} = 0.4 \text{ s}$

12



(a) $\alpha = \frac{a}{r} = \frac{2}{5} = 0.4 \text{ rad s}^{-2}$

(b) $a = \alpha r = 2.5 \times 0.4 = 1 \text{ ms}^{-2}$

13

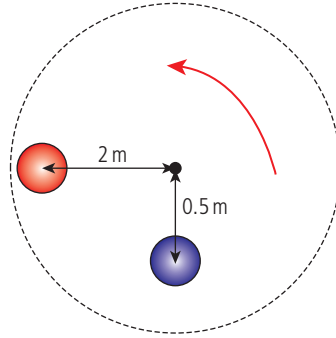

(a) $\omega = 0.25 \times 2\pi = 0.5\pi = 1.57 \text{ rad s}^{-1}$

(b) red child $v = \omega r = 2 \times 0.5\pi = \pi = 3.14 \text{ ms}^{-1}$
 blue child $v = \omega r = 0.5 \times 0.5\pi = 0.25\pi = 0.79 \text{ ms}^{-1}$

(c) $F = m\omega^2 r$

red child $F = 20 \times (0.5\pi)^2 \times 2 = 98.7 \text{ N}$

blue child $F = 20 \times (0.5\pi)^2 \times 0.5 = 24.7 \text{ N}$

14

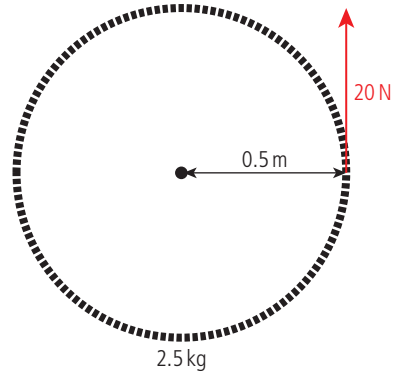

$\Gamma = I\alpha$

$I = mr^2 = 2.5 \times 0.5^2 = 0.625 \text{ kg m}^2$

$\alpha = \frac{\Gamma}{I} = \frac{20}{0.625} = 32 \text{ rad s}^{-2}$

15

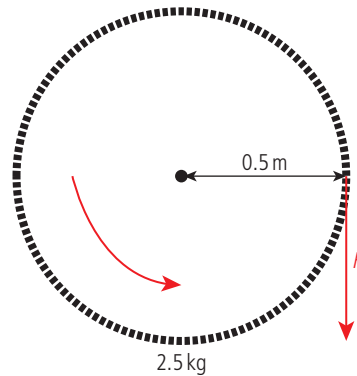

$\omega_i = 2\pi \text{ rad s}^{-1}$

$\omega_f = 0 \text{ rad s}^{-1}$

$t = 1 \text{ s}$

$$\alpha = \frac{(\omega_f - \omega_i)}{t} = -2\pi \text{ rad s}^{-2}$$

$$I = mr^2 = 2.5 \times 0.5^2 = 0.625 \text{ kg m}^2$$

$$\Gamma = I\alpha = 0.625 \times 2\pi = 3.93 \text{ N m}$$

$$\Gamma = Fr$$

$$F = \frac{\Gamma}{r} = \frac{3.93}{0.5} = 7.85 \text{ N}$$

(This is just a spinning wheel; much more force is required if the bike is being ridden.)

16

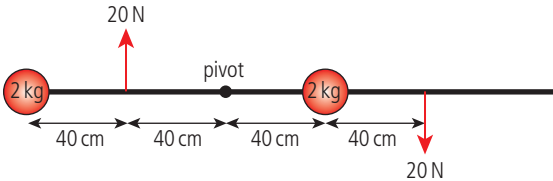

$$I = \Sigma mr^2 = 2 \times 0.8^2 + 2 \times 0.4^2 = 1.6 \text{ kg m}^2$$

$$\text{Total } \Gamma = 20 \times 0.4 + 20 \times 0.8 = 24 \text{ N m}$$

$$\Gamma = I\alpha$$

$$\alpha = \frac{\Gamma}{I} = \frac{24}{1.6} = 15 \text{ rad s}^{-2}$$

17

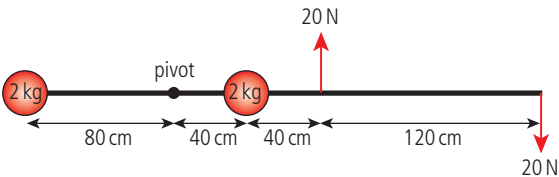

$$I = \Sigma mr^2 = 2 \times 0.8^2 + 2 \times 0.4^2 = 1.6 \text{ kg m}^2$$

$$\text{Total } \Gamma = -20 \times 0.8 + 20 \times 2 = 24 \text{ N m}$$

(clockwise)

$$\Gamma = I\alpha$$

$$\alpha = \frac{\Gamma}{I} = \frac{24}{1.6} = 15 \text{ rad s}^{-2}$$

A couple has the same effect no matter where it acts.

18

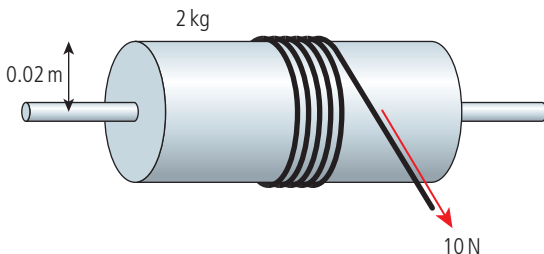

$$(a) I = \frac{1}{2}mr^2 = 0.5 \times 2 \times 0.02^2 = 4 \times 10^{-4} \text{ kg m}^2$$

$$\Gamma = Fr = 10 \times 0.02 = 0.2 \text{ N m}$$

$$\Gamma = I\alpha$$

$$\alpha = \frac{\Gamma}{I} = \frac{0.2}{4 \times 10^{-4}} = 500 \text{ rad s}^{-2}$$

(b) Length of string = 1 m

$$\text{Circumference of cylinder} = 2\pi r = 0.126 \text{ m}$$

$$\text{Number of revolutions} = \frac{1}{0.126} = 7.96$$

(c) $\theta = 7.96 \times 2\pi$

$$\omega_i = 0 \text{ rad s}^{-1}$$

$$\alpha = 500 \text{ rad s}^{-2}$$

$$\omega_f^2 = \omega_i^2 + 2\alpha\theta = 0 + 2 \times 7.96 \times 2\pi \times 500 = 15920\pi$$

$$\omega_f = 224 \text{ rad s}^{-1}$$

19

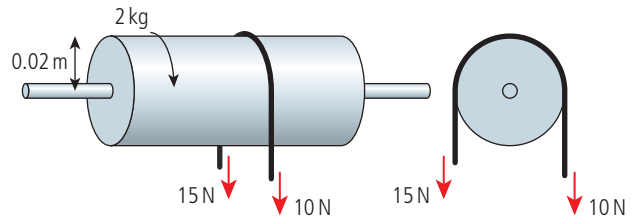

Take clockwise as positive since that is direction of initial rotation

$$(a) \Gamma = -15 \times 0.02 + 10 \times 0.02 = -0.1 \text{ N m}$$

(minus sign means it's acting anticlockwise)

$$(b) I = \frac{1}{2}mr^2 = 0.5 \times 2 \times 0.02^2 = 4 \times 10^{-4} \text{ kg m}^2$$

$$\alpha = \frac{\Gamma}{I} = \frac{-0.1}{4 \times 10^{-4}} = -250 \text{ rad s}^{-2}$$

(c) $\omega_i = 100 \times 2\pi \text{ rad s}^{-1}$

$$\omega_f = 0 \text{ rad s}^{-1}$$

$$\alpha = -250 \text{ rad s}^{-2}$$

$$\alpha = \frac{(\omega_f - \omega_i)}{t}$$

$$t = \frac{(\omega_f - \omega_i)}{\alpha} = \frac{(-200\pi)}{-250} = 2.51 \text{ s}$$

20

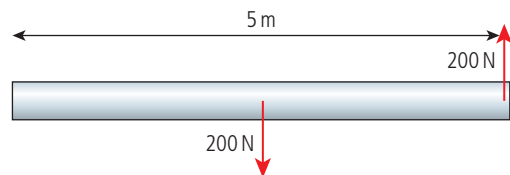

$$(a) \text{Sum of torques} = 200 \times 5 - 200 \times 2.5 = 500 \text{ N m (anticlockwise)}$$

$$(b) I = \frac{1}{3}mL^2 = \frac{1}{3 \times 20 \times 5^2} = 167 \text{ kg m}^2$$

$$\alpha = \frac{\Gamma}{I} = \frac{500}{167} = 3 \text{ rad s}^{-2}$$

21

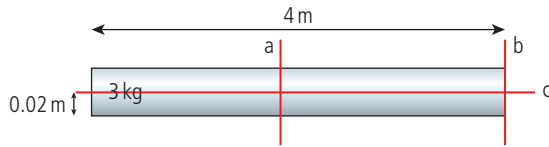

(a) $KE = \frac{1}{2} I \omega^2$

$$I_{\text{centre}} = \frac{1}{12} \times ML^2 = \frac{3 \times 4^2}{12} = 4 \text{ kg m}^2$$

$$\omega = 1 \times 2\pi = 2\pi \text{ rad s}^{-1}$$

$$KE = 0.5 \times 4 \times (2\pi)^2 = 79 \text{ J}$$

(b) $I_{\text{end}} = \frac{1}{3} ML^2 = \frac{3 \times 4^2}{3} = 16 \text{ kg m}^2$

$$KE = 0.5 \times 16 \times (2\pi)^2 = 316 \text{ J}$$

(c) $I = \frac{1}{2} Mr^2 = 0.5 \times 3 \times 0.02^2$

$$= 6 \times 10^{-4} \text{ kg m}^2$$

$$KE = 0.5 \times 6 \times 10^{-4} \times (2\pi)^2$$

$$= 0.012 \text{ J}$$

22

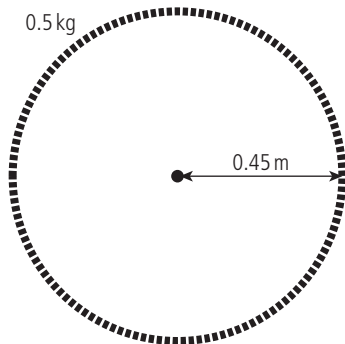

$$\omega = 2 \times 2\pi = 4\pi \text{ rad s}^{-1}$$

$$I = mr^2 = 0.5 \times 0.45^2 = 0.101$$

$$KE = \frac{1}{2} I \omega^2 = 0.5 \times 0.101 \times (4\pi)^2 = 8 \text{ J}$$

(This is just the spinning wheel.)

23



$$mgh = \frac{1}{2} mv^2 + \frac{1}{2} I \omega^2$$

For a hollow sphere $I = \frac{2}{3} mr^2$

If no slipping $\omega = \frac{v}{r}$

$$\frac{1}{2} mv^2 + \frac{1}{2} \left(\frac{2}{3} mr^2 \times \frac{v^2}{r^2} \right) = \frac{1}{2} mv^2 + \frac{2}{6} mv^2$$

$$mgh = \frac{5}{6} mv^2$$

$$v = \sqrt{\frac{6gh}{5}}$$

$\frac{6}{5}$ is less than $\frac{10}{7}$ so the hollow ball will have lower velocity when it reaches the bottom

(it will take more time)

24

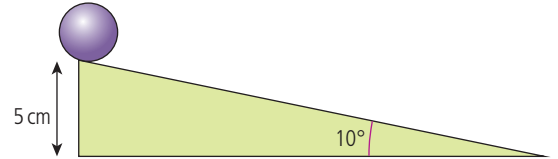

(a) $KE \text{ at bottom} = PE \text{ at top} = mgh$
 $= 0.5 \times 10 \times 0.05 = 0.25 \text{ J}$

(b) since ball is solid

$$v = \sqrt{\frac{10gh}{7}}$$

$$= 0.85 \text{ ms}^{-1}$$

(c) $\sin 10^\circ = \frac{0.05}{L}$

$$L = 0.29 \text{ m}$$

(d) $u = 0 \text{ ms}^{-1}$

$$v = 0.85 \text{ ms}^{-1}$$

$$s = 0.29 \text{ m}$$

$$s = \frac{(u+v)t}{2}$$

$$t = \frac{2s}{(u+v)} = 0.68 \text{ s}$$

25

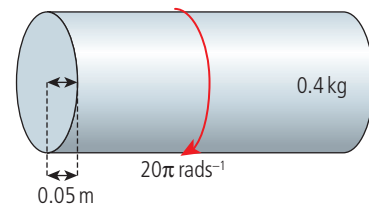

$$I = \frac{1}{2} mr^2 = 5 \times 10^{-4} \text{ kg m}^2$$

$$L = I\omega = 5 \times 10^{-4} \times 20\pi = \pi \times 10^{-2}$$

$$= 3.14 \times 10^{-2} \text{ kg m}^2 \text{ s}^{-1}$$

26

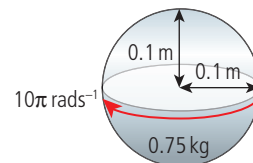

$$I = \frac{2}{5} mr^2 = 3 \times 10^{-3} \text{ kg m}^2$$

$$L = I\omega = 3 \times 10^{-3} \times 10\pi = 3\pi \times 10^{-2}$$

$$= 0.942 \text{ kg m}^2 \text{ s}^{-1}$$

27 (a)

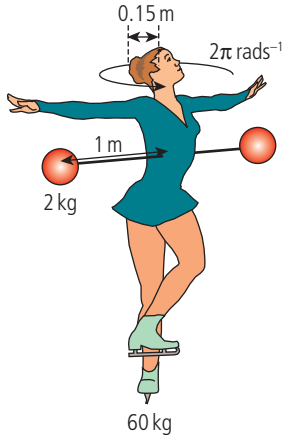

$$I_1 = I_{\text{body}} + I_{\text{arms}}$$

$$= \frac{1}{2} \times 60 \times 0.15^2 + 2 \times 2 \times 1^2 = 4.675 \text{ kg m}^2$$

(b)

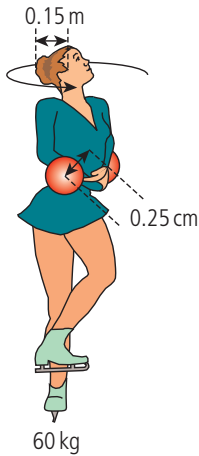

$$I_2 = \frac{1}{2} \times 60 \times 0.15^2 + 2 \times 2 \times 0.25^2$$

$$= 0.925 \text{ kg m}^2$$

(c) $I_1 \omega_1 = I_2 \omega_2$

$$4.675 \times 2\pi = 0.925 \times \omega_2$$

$$\omega_2 = 5.1 \times 2\pi \text{ rad s}^{-1}$$

$$5.1 \text{ revolutions s}^{-1}$$

(d) KE before = $\frac{1}{2} I_1 \omega_1^2 = 0.5 \times 4.675 \times (2\pi)^2$

$$= 92.3 \text{ J}$$

$$\text{KE after} = \frac{1}{2} I_2 \omega_2^2 = 0.5 \times 0.925 \times (10.2\pi)^2$$

$$= 475 \text{ J}$$

(e) Work done pulling her arms in

28

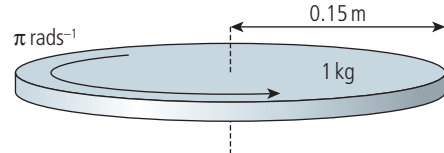

(a) $I_1 = \frac{1}{2} m r^2 = 0.5 \times 1 \times 0.15^2$

$$= 1.125 \times 10^{-2} \text{ kg m}^2$$

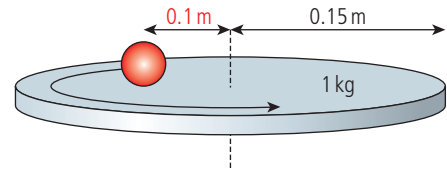

(b) $I_2 = 1.125 \times 10^{-2} + m r^2$

$$= 1.125 \times 10^{-2} + 0.1 \times 0.1^2$$

$$= 1.225 \times 10^{-2} \text{ kg m}^2$$

(c) $I_1 \omega_1 = I_2 \omega_2$

$$\omega_2 = \frac{1.125 \times \pi}{1.225} = 0.92 \pi = 2.9 \text{ rad s}^{-1}$$

29

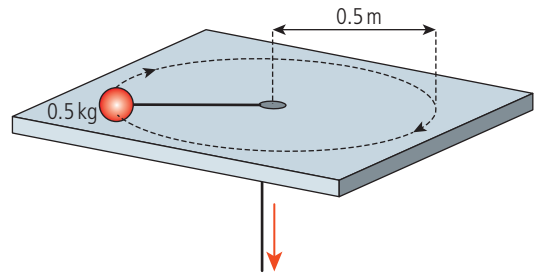

(a) $L = I \omega$

$$I_1 = m r^2 = 0.5 \times 0.5^2 = 0.125 \text{ kg m}^2$$

$$\omega_1 = \frac{v}{r} = \frac{2}{0.5} = 4 \text{ rad s}^{-1}$$

$$L_1 = 0.5 \text{ kg m}^2 \text{ s}^{-1}$$

(b) $I_1 \omega_1 = I_2 \omega_2$

$$I_2 = m r^2 = 0.5 \times 0.2^2 = 0.02 \text{ kg m}^2$$

$$\omega_2 = \frac{L_1}{I_2} = 25 \text{ rad s}^{-1}$$

$$\text{speed} = \omega_2 r = 5 \text{ m s}^{-1}$$

30

1 mole Ar = 40 g

number of moles $n = \frac{100}{40}$ moles = 2.5 moles

$$U = \frac{3}{2} n R T = 1.5 \times 2.5 \times 8.31 \times 300 = 9.4 \text{ kJ}$$

31

$$\text{Average KE} = \frac{3}{2} k T = 1.5 \times 1.38 \times 10^{-23} \times 400$$

$$= 8.28 \times 10^{-21} \text{ J}$$

32 $P_1 = 70 \text{ kPa}$

$V_1 = 100 \times 10^{-6} \text{ m}^3$

$V_2 = 50 \times 10^{-6} \text{ m}^3$

(a) $PV = nRT$

$$T_1 = \frac{PV_1}{nR} = \frac{70 \times 10^3 \times 100 \times 10^{-6}}{0.01} = 700 \text{ K}$$

(b) $T_2 = \frac{PV_2}{nR} = \frac{70 \times 10^3 \times 50 \times 10^{-6}}{0.01} = 350 \text{ K}$

(c) $\Delta U = \frac{3}{2} nR\Delta T = 1.5 \times 0.01 \times 350 = 5.25 \text{ J}$

(d) Work done = $P\Delta V = 70 \times 10^3 \times 50 \times 10^{-6} = 3.5 \text{ J}$

(e) $Q = \Delta U + W$

Work done by gas = -3.5 J

Change in internal energy = -5.25 J

Heat loss = 8.75 J

33

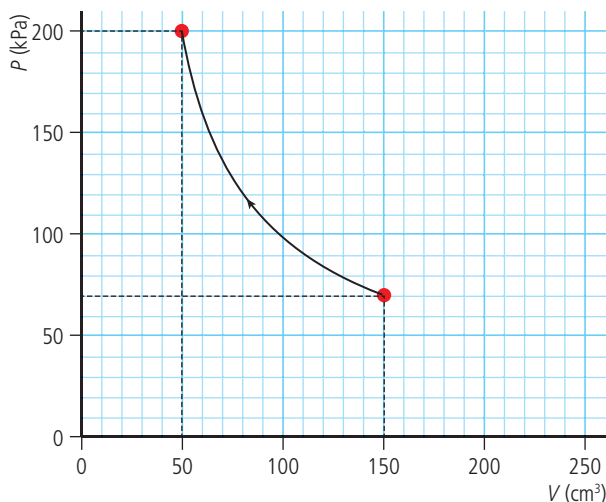

$P_1 = 70 \times 10^3 \text{ Pa}$

$V_1 = 150 \times 10^{-6} \text{ m}^3$

$P_2 = 200 \times 10^3 \text{ Pa}$

$V_2 = 50 \times 10^{-6} \text{ m}^3$

(a) $T = \frac{PV}{nR} = \frac{70 \times 10^3 \times 150 \times 10^{-6}}{0.01} = 1050 \text{ K}$

(b) Work done = area under curve = $70 + 46 = 116$ squares

Each square = $10 \times 10^3 \times 10 \times 10^{-6} = 0.1 \text{ J}$

Work done = 11.6 J

(c) Temperature is constant so no change in internal energy

heat loss = work done on gas = 11.6 J

34

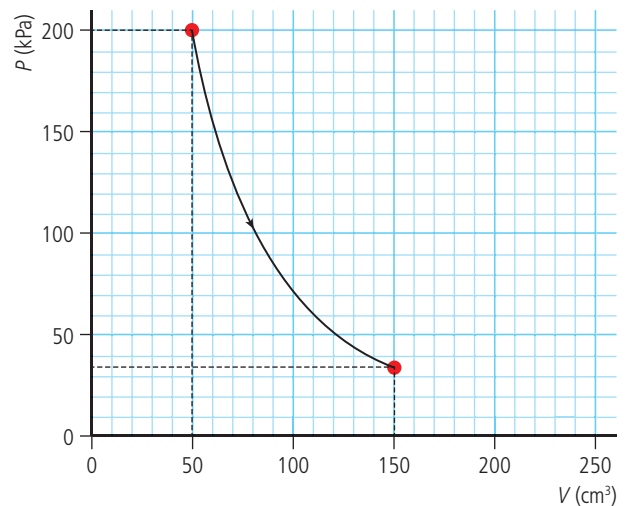

(a) Adiabatic so $PV^{\frac{5}{3}} = \text{constant}$

$$P_1 V_1^{\frac{5}{3}} = P_2 V_2^{\frac{5}{3}}$$

$$200 \times 10^3 \times (52 \times 10^{-6})^{\frac{5}{3}}$$

$$= P_2 \times (150 \times 10^{-6})^{\frac{5}{3}}$$

$$P_2 = 34 \text{ kPa}$$

Close, given the difficulty in reproducing and reading the graph.

(b) Expansion, so the gas does work

Work is area under graph = 83 squares

As before, each square

$$= 10 \times 10^3 \times 10 \times 10^{-6} = 0.1 \text{ J}$$

So the gas does work = 8.3 J

(c) $T_1 = \frac{P_1 V_1}{nR} = \frac{200 \times 10^3 \times 52 \times 10^{-6}}{0.01} = 1040 \text{ K}$

(d) $T_2 = \frac{P_2 V_2}{nR} = \frac{34 \times 10^3 \times 150 \times 10^{-6}}{0.01} = 510 \text{ K}$

(e) $\Delta U = \frac{3}{2} nR\Delta T = 1.5 \times 0.01 \times (510 - 1040) = -7.95 \text{ J}$

(f) $Q = \Delta U + W = -7.95 + 8.3 = 0.35 \text{ J}$

(This should be zero but is not, owing to the difficulty in estimating the area under the graph.)

35 (a)

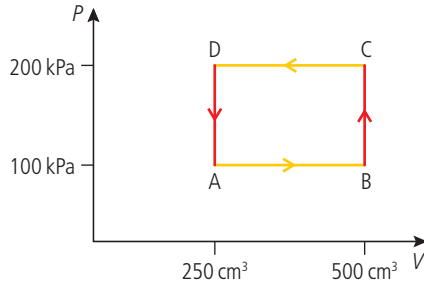

(b) (i) $\frac{P_A V_A}{T_A} = \frac{P_B V_B}{T_B} \Rightarrow \frac{100 \times 250}{300} = \frac{100 \times 500}{T_B}$

$T_B = 600 \text{ K}$

(ii) $\frac{P_B V_B}{T_B} = \frac{P_C V_C}{T_C} \Rightarrow \frac{100 \times 500}{600} = \frac{200 \times 500}{T_C}$

$T_C = 1200 \text{ K}$

(iii) $\frac{P_C V_C}{T_C} = \frac{P_D V_D}{T_D} \Rightarrow \frac{200 \times 500}{1200} = \frac{200 \times 250}{T_D}$

$T_D = 600 \text{ K}$

(c) Work done by gas from $A \rightarrow B$ = area under graph

$= 100 \times 10^3 \times 250 \times 10^{-6} = 25 \text{ J}$

(d) Work done on gas from $C \rightarrow D$ = area under graph

$= 200 \times 10^3 \times 250 \times 10^{-6} = -50 \text{ J}$

(e) Net work done by gas = -25 J (25 J of work done on gas)

36

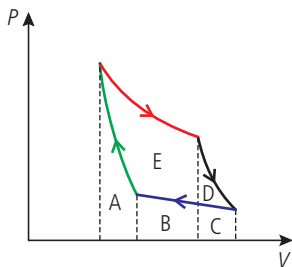

Each area marked with a letter represents an energy:

A – 50 J, B – 45 J, C – 40 J, D – 35 J, E – 150 J

(a) Isothermal expansion

Work done = area under red curve = A + B + E

Work done = 245 J

(b) Adiabatic compression

Work done = area under green curve = A

Work done = 50 J

(c) Gas does work when it expands

Work done = area under red and black curves = A + B + C + D + E

Work done = 320 J

(d) Work done on gas when it is compressed

Work done = area under green and blue curves = A + B + C

Work done = 135 J

(e) Net work done = E + D = 185 J

37

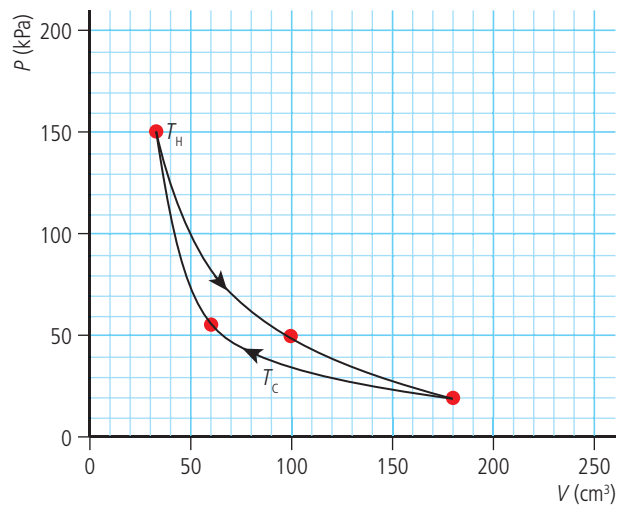

(a) At top point $\frac{PV}{nR} = \frac{150 \times 10^3 \times 35 \times 10^{-6}}{0.01}$

$= 525 \text{ K}$

(b) At bottom point $\frac{PV}{nR} = \frac{20 \times 10^3 \times 180 \times 10^{-6}}{0.01}$

$= 360 \text{ K}$

(c) $\eta = \frac{1 - T_C}{T_H} = 1 - \frac{360}{525} = 0.31 (\approx 0.3)$

(d) Net work = area enclosed = 14 squares = $14 \times 10 \times 10^3 \times 10 \times 10^{-6} = 1.4 \text{ J}$

(e) Heat added = work done = area under isothermal expansion = 48 squares = 4.8 J

(f) $\eta = \frac{W}{Q_H} = \frac{1.4}{4.8} = 0.29 (\approx 0.3)$

38 Entropy = $\frac{\Delta Q}{T}$

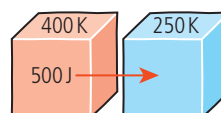

- (a) (i) Entropy lost by hot body = $\frac{-500}{400}$
 $= -1.25 \text{ J/K}$
- (ii) Entropy gained by cold body = $\frac{+500}{250}$
 $= +2 \text{ J/K}$
- (b) Change in entropy = $2 + (-1.25)$
 $= +0.75 \text{ J/kg}$

- 39 Lifting a load increases PE of load. Motor transfers electrical energy to PE. PE of load is more ordered than electrical energy in battery. \Rightarrow Heat must be lost otherwise entropy would be reduced.

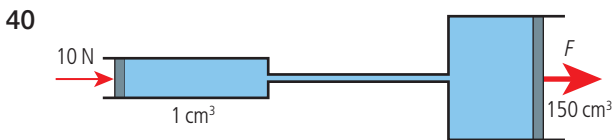

- (a) $P = \frac{F}{A} = \frac{10}{1 \times 10^{-4}} = 10^5 \text{ Pa}$
- (b) $P = \frac{F}{A}$

The pressure in the fluid is the same everywhere: $\frac{10}{1} = \frac{F}{150}$
 $F = 1500 \text{ N}$

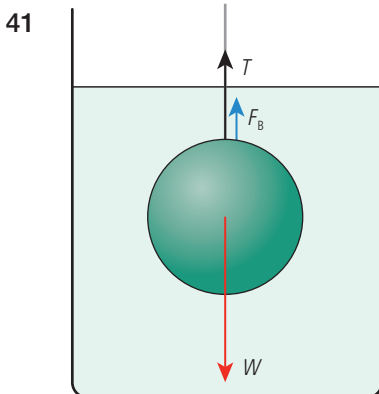

- $m = 60 \text{ kg}$
 $\rho_g = 19.3 \times 10^3 \text{ kg m}^{-3}$
 $V = \frac{m}{\rho_g} = 3.1 \times 10^{-3} \text{ m}^3$
 Mass of water displaced = $V\rho_w$
 $= 3.1 \times 10^{-3} \times 1 \times 10^3 = 3.1 \text{ kg}$
 Buoyant force, $F_B = 31 \text{ N}$
 To lift ball $T = W - F_B = 600 - 31 = 569 \text{ N}$

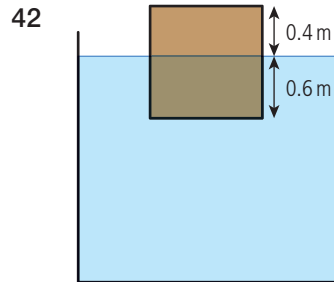

- (a) Volume of wood under water
 $= 0.6 \times 1 \times 1 = 0.6 \text{ m}^3$
 Mass of water displaced = $V\rho_w$
 $= 0.6 \times 10^3 \text{ kg}$
 Buoyant force = 6000 N
 Floating, so buoyant force = weight of wood = 6000 N
 Mass of wood = 600 kg
 Density of wood = 600 kg m^{-3}
- (b) If the cube is pushed under water, mass of water displaced = $V\rho_w = 1 \times 10^3 \text{ kg}$
 Upthrust = 10000 N

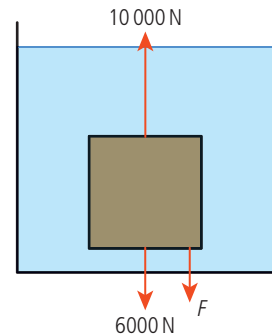

$$F + 6000 = 10000$$

$$F = 4000 \text{ N}$$

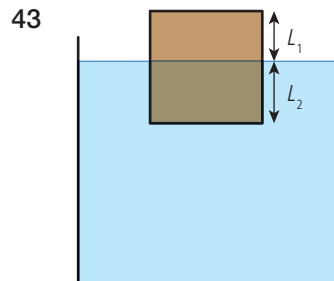

- If area of cube = A , then weight of water displaced = $L_2 \times A \times \rho_w \times g$
 Weight of ice = $(L_1 + L_2) \times A \times \rho_i \times g$

The ice is floating, so

$$L_2 \times A \times \rho_w \times g = (L_1 + L_2) \times A \times \rho_i \times g$$

$$\frac{L_2}{(L_1 + L_2)} = \frac{\rho_i}{\rho_w} = \frac{0.92}{1.03} = 0.89$$

This means that 89% is under water.

44

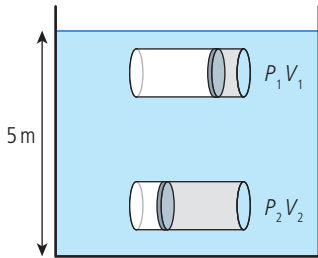

Pressure at depth 5 m = $P_{\text{atmos}} + \rho gh$
 $101 \times 10^3 + 10^3 \times 10 \times 5 = 151 \times 10^3$
 $= 151 \text{ kPa}$

Assume the temperature is constant

$$P_1 V_1 = P_2 V_2$$

$$101 \times 100 = 151 \times V_2$$

$$V_2 = 67 \text{ cm}^3$$

45

$$A_1 v_1 = A_2 v_2$$

$$20 \times 3 \times 1 = 20 \times 1 \times v_2$$

$$v_2 = 3 \text{ ms}^{-1}$$

46

Volume flow is the same = 1.5

$$= \pi (0.25)^2 \times v_2$$

$$v_2 = 7.6 \text{ ms}^{-1}$$

47

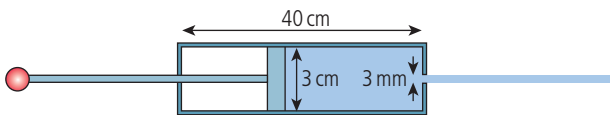

$$v_1 = \text{velocity of piston} = \frac{0.4}{4} = 0.1 \text{ ms}^{-1}$$

$$A_1 v_1 = A_2 v_2$$

$$\pi \times (0.03)^2 \times 0.1 = \pi \times (0.003)^2 \times v_2$$

$$v_2 = 10 \text{ ms}^{-1}$$

48

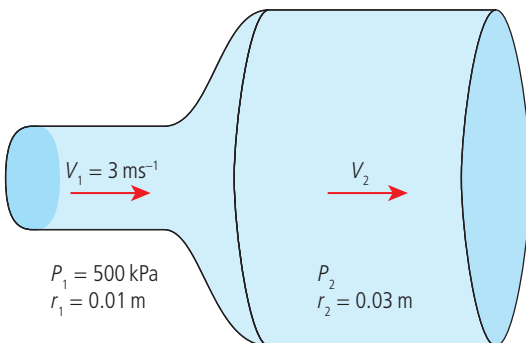

(a) Volume flow rate = $A_1 v_1 = \pi \times (0.01)^2 \times 3$
 $= 9.4 \times 10^{-4} \text{ m}^3 \text{ s}^{-1}$

(b) Using the continuity equation $A_1 v_1 = A_2 v_2$

$$\pi \times (0.01)^2 \times 3 = \pi \times (0.03)^2 \times v_2$$

$$v_2 = \left(\frac{0.01}{0.03}\right)^2 \times 3 = 0.33 \text{ ms}^{-1}$$

(c) $P_1 + \frac{1}{2} \rho v_1^2 + \rho gh_1 = P_2 + \frac{1}{2} \rho v_2^2 + \rho gh_2$

No change in height so

$$P_1 + \frac{1}{2} \rho v_1^2 = P_2 + \frac{1}{2} \rho v_2^2$$

$$500 \times 10^3 + 0.5 \times 10^3 \times 3^2$$

$$= P_2 + 0.5 \times 10^3 \times 0.33^2$$

$$P_2 = (500 + 4.5 - 0.054) \times 10^3 = 504.4 \text{ kPa}$$

49

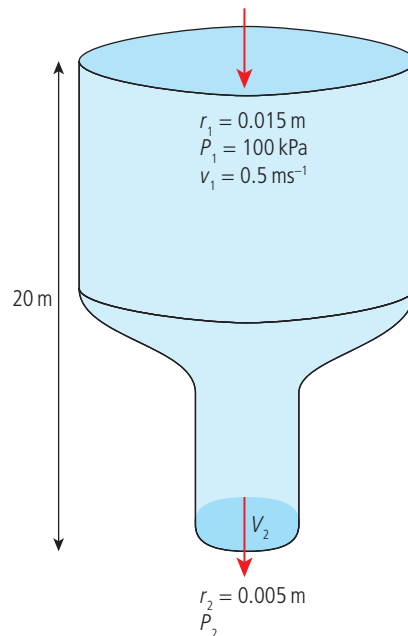

(a) Volume flow rate = $A_1 v_1 = \pi \times (0.015)^2 \times 0.5$
 $= 3.53 \times 10^{-4} \text{ m}^3 \text{ s}^{-1}$

(b) Using continuity equation $A_1 v_1 = A_2 v_2$

$$\pi \times (0.015)^2 \times 0.5 = \pi \times (0.005)^2 \times v_2$$

$$v_2 = \left(\frac{0.015}{0.005}\right)^2 \times 0.5 = 4.5 \text{ ms}^{-1}$$

(c) $P_1 + \frac{1}{2} \rho v_1^2 + \rho gh_1 = P_2 + \frac{1}{2} \rho v_2^2 + \rho gh_2$

$$100 \times 10^3 + 0.5 \times 10^3 \times 0.5^2 + 10^3 \times 10 \times 20$$

$$= P_2 + 0.5 \times 10^3 \times 4.5^2$$

$$P_2 = (100 + 0.125 + 200 - 10.0125) \times 10^3$$

$$P_2 = 290 \text{ kPa}$$

50

density of air = 1.3 kg m^{-3}

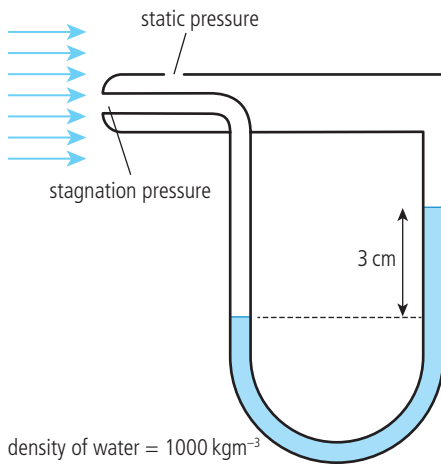

$$P_2 - P_1 = \rho_w g \Delta h = \frac{1}{2} \rho_a v^2$$

$$v = \sqrt{\frac{2 \rho_w g \Delta h}{\rho_a}} = \sqrt{\frac{2 \times 1000 \times 10 \times 0.03}{1.3}} = 21.5 \text{ m s}^{-1}$$

51

$$P_2 - P_1 = \frac{1}{2} \rho_a v^2$$

$$600 \text{ km h}^{-1} = 600 \times \frac{1000}{3600} = 166.7 \text{ m s}^{-1}$$

$$\Delta P = 0.5 \times 1.3 \times 166.7^2 = 18 \text{ kPa}$$

52

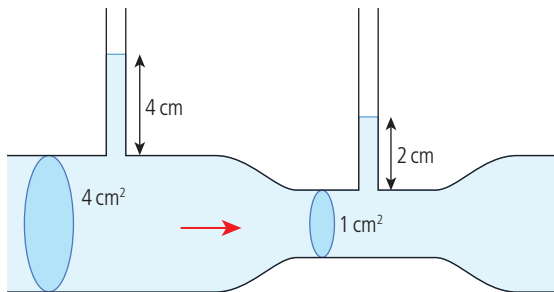

$$g \Delta h = \frac{1}{2} v_1^2 \left[\left(\frac{A_1}{A_2} \right)^2 - 1 \right]$$

$$v_1 = \sqrt{\frac{2g\Delta h}{\left(\frac{A_1}{A_2} \right)^2 - 1}}$$

$$\frac{A_1}{A_2} = 4$$

$$v_1 = \sqrt{\frac{2 \times 10 \times 0.02}{4^2 - 1}} = 0.163 \text{ m s}^{-1}$$

$$\text{Volume flow rate} = A_1 v_1 = 4 \times 10^{-4} \times 0.163 = 6.5 \times 10^{-5} \text{ m}^3 \text{ s}^{-1}$$

53

Density of oil = 900 kg m^{-3}

Density of steel = 8000 kg m^{-3}

Viscosity of oil = 0.2 N s m^{-2}

$$\begin{aligned} v_t &= \frac{2}{9} \times \frac{gr^2}{\eta} (\rho_s - \rho_f) \\ &= \frac{2}{9} \times \frac{10 \times 0.005^2}{0.2} (8000 - 900) \\ &= 1.97 \text{ m s}^{-1} \end{aligned}$$

$$\begin{aligned} 54 \quad \rho_s &= \frac{9 \times v_t \times \eta}{2 \times gr^2} + \rho_f = \frac{9 \times 0.5 \times 0.2}{2 \times 10 \times 0.03^2} + 900 \\ &= 50 + 900 \\ \rho_s &= 950 \text{ kg m}^{-3} \end{aligned}$$

$$\begin{aligned} 55 \quad R_e &= \frac{vr\rho}{\eta} \\ \text{Turbulent if } R_e &> 1000 \end{aligned}$$

$$v = \frac{1000 \times 0.002}{0.01 \times 1000} = 0.2 \text{ m s}^{-1}$$

$$\begin{aligned} \text{Volume flow rate} &= Av = \pi \times (0.01)^2 \times 0.2 \\ &= 6.3 \times 10^{-5} \text{ m}^3 \text{ s}^{-1} \end{aligned}$$

56



$$\text{If } f = 0.5 \text{ Hz, the time period} = \frac{1}{0.5} = 2 \text{ s}$$

$$Q = 2\pi \frac{\text{energy stored}}{\text{energy lost per cycle}}$$

$$Q = 2\pi \frac{25}{(25 - 9)} = 9.8$$

57

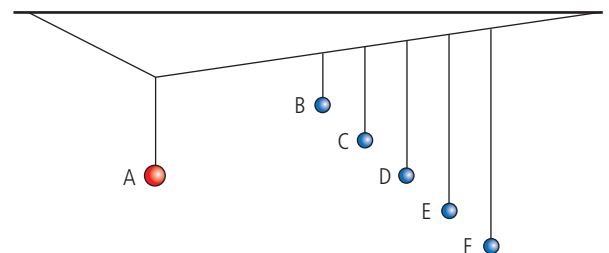

(a) D is same length as A so resonance – this implies a $\frac{\pi}{2}$ phase difference.

B is much shorter so driver has lower frequency – it will be in phase.
 F is much longer so driver has higher frequency – it will have a π phase difference.
 C and E will be somewhere in between.

- (b) D has highest amplitude as it resonates with the driver.

Practice questions

- 1 (a) The conditions for equilibrium are that the sum of the forces acting on the body are zero and the sum of the torques about any point is zero.
 (b) The forces must add to zero so the resultant force must close the triangle of forces as shown.

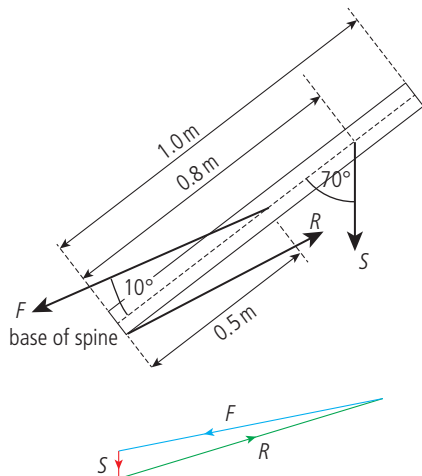

- (c) Torque about base = $S \times \sin 70^\circ \times 0.8$
 (d) If in equilibrium torques about base are balanced so
 clockwise torque = anticlockwise torque
 $S \times \sin 70^\circ \times 0.8 = F \times \sin 10^\circ \times 0.5$
 $\frac{F}{S} = \frac{0.8 \times \sin 70^\circ}{0.5 \times \sin 10^\circ} = 8.66 \approx 9$

- 2 (a) The radius should be marked as 2 m.
 Moment of inertia = $I_{\text{disc}} + I_{\text{child}}$
 $= \frac{1}{2} m_d r^2 + m_c r^2$
 $= 0.5 \times 60 \times 2^2 + 40 \times 2^2$
 $I = 280 \text{ kgm}^2$

- (b) $L = I\omega = 280 \times \pi = 880 \text{ kgm}^2\text{s}^{-1}$
 (c) No external torques act so angular momentum is conserved.
 Initial angular momentum = final angular momentum

$$I_1 \omega_1 = I_2 \omega_2$$

$$I_2 = 0.5 \times 60 \times 2^2 + 40 \times 1^2 = 160 \text{ kgm}^2$$

$$\omega_2 = \frac{I_1 \omega_1}{I_2} = \frac{880}{160} = 5.50 \text{ rad s}^{-1}$$

- (d) Rotational KE = $\frac{1}{2} I \omega^2$
 Initial KE = $0.5 \times 880 \times \pi^2 = 1380 \text{ J}$
 Final KE = $0.5 \times 160 \times 5.5^2 = 2420 \text{ J}$
 Change in KE = $2420 - 1380 = 1040 \text{ J}$
 (e) The increase in KE is due to the work done by the child pulling himself towards the centre.

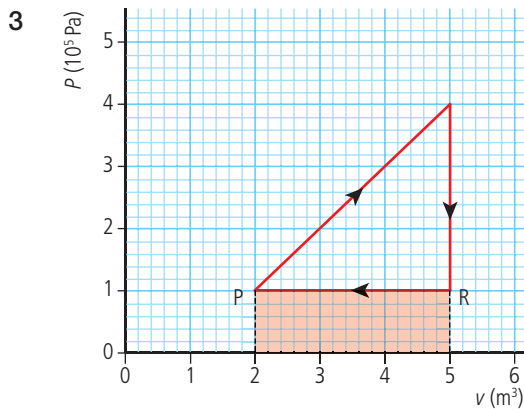

Work done compressing gas = area under line
 $= 1 \times 10^5 \times 3 = 3 \times 10^5 \text{ J}$
 The answer is C.

- 4 (a) Work done during cycle = area inside cycle
 $= 2 \times 10^5 \times 8 = 1.6 \times 10^6 \text{ J}$

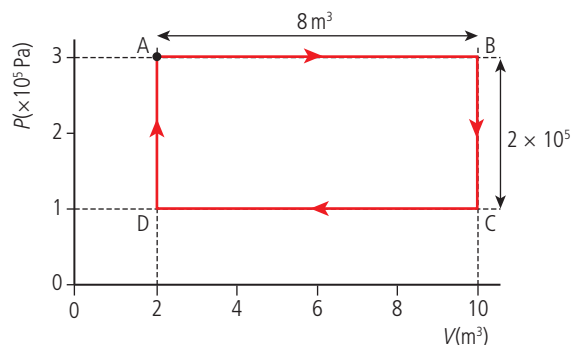

(b) $1.8 \times 10^6 \text{ J}$ thermal energy ejected

So the energy in must equal

work done + energy lost

$$= (1.6 + 1.8) \times 10^6 = 3.4 \times 10^6 \text{ J}$$

$$\text{Efficiency} = \frac{\text{work out}}{\text{energy in}} \times 100\%$$

$$= \frac{1.6}{3.4} \times 100\% = 47\%$$

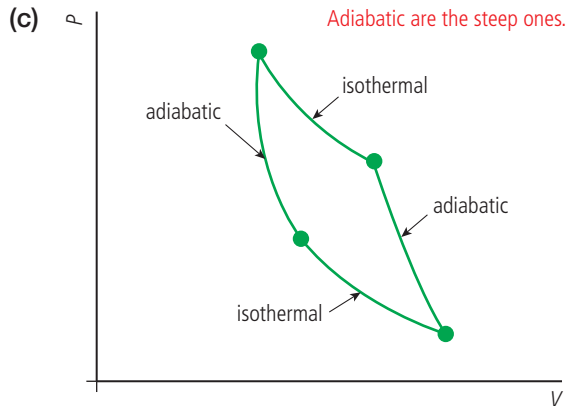

- (d) (i) Adiabatic expansion
Adiabatic compression
Isothermal expansion
Isothermal compression

- 5 (a) Isothermal – the temperature remains constant but heat enters or leaves.
Adiabatic – no heat exchanged with surroundings and temperature not constant.

(b) (i) $\frac{PV}{T} = \text{constant}$

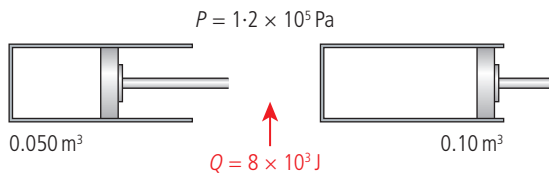

P is constant so when V increases T must increase \Rightarrow not isothermal

Heat added \Rightarrow not adiabatic

\therefore not adiabatic or isothermal; it is isobaric

(ii) Work done on gas $= P\Delta V$
 $= 1.2 \times 10^5 \times 0.05 = 6 \times 10^3 \text{ J}$

(iii) According to first law of thermodynamics

$$Q = \Delta U + W \Rightarrow \Delta U = Q - W$$

Gain in internal energy

$=$ heat added $-$ work done by gas

$$\Delta U = 8 \times 10^3 - 6 \times 10^3 = 2 \times 10^3 \text{ J}$$

- 6 (a) (i) $A \rightarrow B$ the volume is getting less \Rightarrow gas compressed so work is done on the gas.

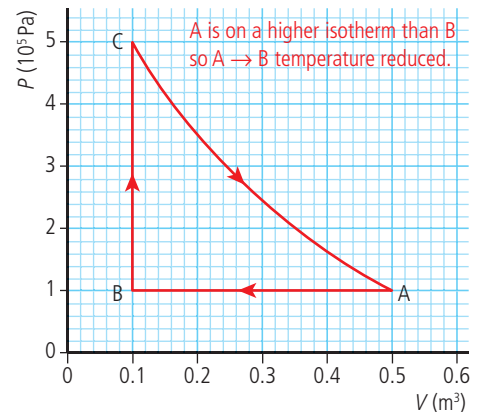

(ii) Temperature of gas goes down and work is done on gas.

$$\text{First law: } Q = \Delta U + W$$

If ΔU and W are both negative then Q is negative \Rightarrow heat lost.

(b) Work done from $A \rightarrow B =$ area under $A-B = 1 \times 10^5 \times 0.4 = 0.4 \times 10^5 \text{ J}$

(c) Total work done $=$ area of 'triangle' ABC
 $= \frac{1}{2} \times 4 \times 10^5 \times 0.4 = 0.8 \times 10^5 \text{ J}$

(d) Useful work done $= 8 \times 10^4 \text{ J}$

Thermal energy supplied $= 120 \text{ kJ}$

$$= 12 \times 10^4 \text{ J}$$

$$\text{Efficiency} = \frac{\text{useful work}}{\text{energy in}} \times 100 = \frac{8}{12} \times 100$$

$$= 67\%$$

c. and d. are overestimates since the area is a bit less than the area of the triangle.

- 7 (a) Isothermal is not as steep as adiabatic
so AC – adiabatic
AB – isothermal

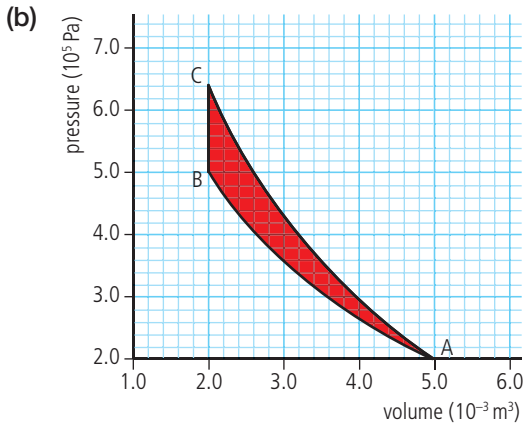

Net work done is area inside the cycle

- (c) Estimate by counting small squares ~ 150
 Each square is $0.1 \times 10^5 \times 0.1 \times 10^{-3} = 1 \text{ J}$
 so work done = 150 J
- (d) Adiabatic \Rightarrow no exchange of heat $\Rightarrow Q = 0$
 First law states $Q = \Delta U + W$
 Heat added = increase in internal energy +
 work done by gas
 In this case $Q = 0$
 and W is negative since work is done on
 gas
 $\Rightarrow 0 = \Delta U - W$
 $\Rightarrow \Delta U = W$
 \therefore Internal energy increases
 \Rightarrow Temperature increases

- 8 (a) Volume per second = $Av = \pi \times 0.02^2 \times 0.5$
 $= 6.3 \times 10^{-4} \text{ m}^3 \text{ s}^{-1}$;
- (b) Using continuity equation
 $A_1 v_1 = A_2 v_2$
 $\pi \times 0.02^2 \times 0.5 = \pi \times 0.015^2 \times v_2$;
 $v_2 = 0.9 \text{ ms}^{-1}$;
- (c) Using Bernoulli equation
 $P_1 + \frac{1}{2} \rho v_1^2 + \rho g h_1 = P_2 + \frac{1}{2} \rho v_2^2 + \rho g h_2$;
 $300 \times 10^3 + 0.5 \times 10^3 \times 0.5^2 + 10^3 \times 10 \times 0$
 $= P_2 + 0.5 \times 10^3 \times 0.9^2 + 10^3 \times 10 \times 5$
 $\Rightarrow P_2 = (300 + 0.125 - 0.405 - 50) \times 10^3$
 $= 250 \text{ kPa}$;
- 9 (a) Using Bernoulli equation
 $P_1 + \frac{1}{2} \rho v_1^2 + \rho g h_1 = P_2 + \frac{1}{2} \rho v_2^2 + \rho g h_2$
 Assume difference in height is negligible
 $P_1 + \frac{1}{2} \rho v_1^2 = P_2 + \frac{1}{2} \rho v_2^2$
 $P_1 - P_2 = \frac{1}{2} \rho (v_2^2 - v_1^2)$
 $= 0.5 \times 1.3 \times (340^2 - 290^2)$
 $\Delta P = 2.05 \times 10^4 \text{ Pa}$
- (b) Upward force = $\Delta P \times A = 2.05 \times 10^4 \times 90$
 $= 1.8 \times 10^6 \text{ N}$

Worked solutions

Chapter 11

Exercises

1

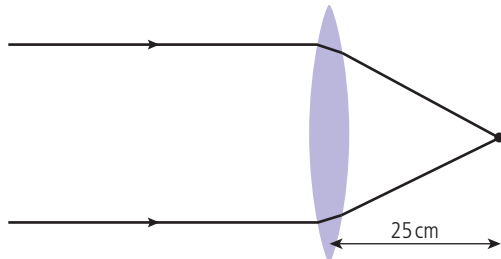

Distance = focal length = 25 cm

$$\frac{1}{u} + \frac{1}{v} = \frac{1}{f}$$

$$\frac{1}{\infty} + \frac{1}{v} = \frac{1}{f}$$

$$v = f$$

2

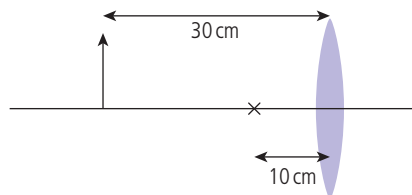

(a) $u = 30 \text{ cm}$

$f = 10 \text{ cm}$

$$\frac{1}{u} + \frac{1}{v} = \frac{1}{f}$$

$$\frac{1}{30} + \frac{1}{v} = \frac{1}{10}$$

$$\frac{1}{v} = \frac{1}{10} - \frac{1}{30} = \frac{3-1}{30} = \frac{2}{30}$$

$$v = 15 \text{ cm}$$

(b) Real

(c) $M = \frac{v}{u} = \frac{15}{30} = 0.5$

3

$u = ?$

$v = 20 \text{ cm}$

$f = 5 \text{ cm}$

$$\frac{1}{u} + \frac{1}{20} = \frac{1}{5}$$

$$\frac{1}{u} = \frac{1}{5} - \frac{1}{20} = \frac{4-1}{20} = \frac{3}{20}$$

$$u = 6.67 \text{ cm}$$

4

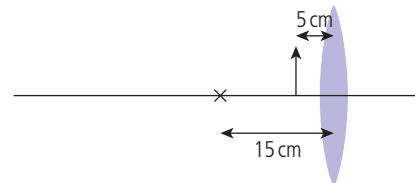

(a) $u = 5 \text{ cm}$

$v = ?$

$f = 15 \text{ cm}$

$$\frac{1}{5} + \frac{1}{v} = \frac{1}{15}$$

$$\frac{1}{v} = \frac{1}{15} - \frac{1}{5} = \frac{1-3}{15} = -\frac{2}{15}$$

$$v = -7.5 \text{ cm}$$

(b) Virtual (negative)

(c) $M = \frac{v}{u} = \frac{7.5}{5} = 1.5$

5

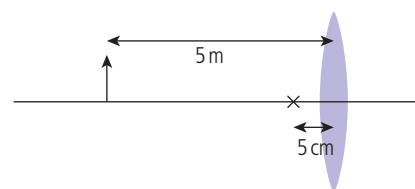

(a) $u = 5 \text{ m}$

(b) $u = 500 \text{ cm}$

$v = ?$

$v = 5 \text{ cm}$

$$\frac{1}{500} + \frac{1}{v} = \frac{1}{5}$$

$$\frac{1}{v} = \frac{1}{5} - \frac{1}{500} = \frac{100-1}{500} = \frac{99}{500}$$

$$v = 5.05 \text{ cm}$$

(c) $M = \frac{v}{u} = \frac{5.05}{500} = 0.01$

(d) If bush is 1 m then image is 0.01 m.

6

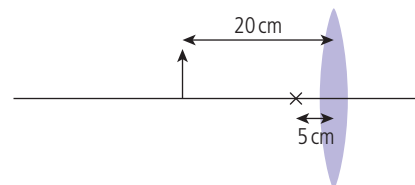

(a) $u = 20 \text{ cm}$

$v = ?$

$f = 5 \text{ cm}$

$$\frac{1}{20} + \frac{1}{v} = \frac{1}{5}$$

$$\frac{1}{v} = \frac{1}{5} - \frac{1}{20} = \frac{4-1}{20} = \frac{3}{20}$$

$$v = 6.67 \text{ cm}$$

$$(b) M = \frac{v}{u} = \frac{6.6}{20} = 0.33$$

$$7 (a) f = -0.3 \text{ m}$$

$$u = 5 \text{ m}$$

$$\frac{1}{f} = \frac{1}{u} + \frac{1}{v} \text{ gives } \frac{1}{v} = \frac{1}{f} - \frac{1}{u}$$

$$\frac{1}{v} = \frac{1}{-0.3} - \frac{1}{5} = \frac{-50-3}{15} = \frac{-53}{15}$$

$$v = -28.3 \text{ cm}$$

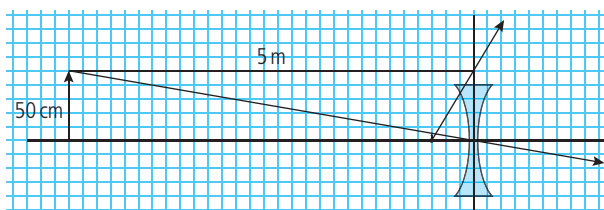

$$(b) \text{ Linear magnification} = \frac{v}{u} = \frac{0.283}{5} = 0.057$$

So if object is 50 cm as in diagram, image will be $50 \times 0.057 = 2.85 \text{ cm}$ which is about the same as the diagram.

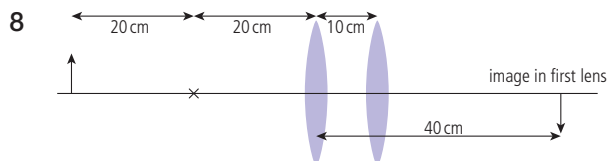

1st lens:

Object is $2f$ from lens so image distance will be $2f$. Image is real.

2nd lens:

Image in 1st lens is object for 2nd but since rays will not cross at this image/object it is taken to be a virtual object.

$$u = -30 \text{ cm}$$

$$f = 20 \text{ cm}$$

$$\frac{1}{f} = \frac{1}{u} + \frac{1}{v} \text{ gives } \frac{1}{v} = \frac{1}{f} - \frac{1}{u}$$

$$\frac{1}{v} = \frac{1}{20} - \frac{1}{-30} = \frac{3+2}{60}$$

$$v = 12 \text{ cm}$$

Image is real.

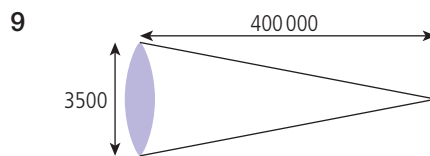

$$\alpha = \frac{3500}{400000} = 8.75 \times 10^{-3} \text{ rad}$$



$$\alpha = \frac{1}{250} = 4 \times 10^{-3} \text{ rad}$$

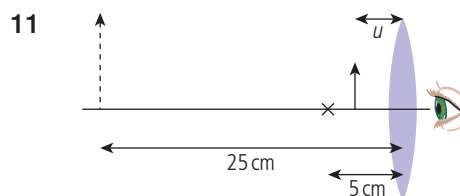

$$u = ?$$

$$v = -25 \text{ cm}$$

$$f = 5 \text{ cm}$$

$$\frac{1}{u} - \frac{1}{25} = \frac{1}{5}$$

$$\frac{1}{u} = \frac{1}{5} + \frac{1}{25} = \frac{5+1}{25} = \frac{6}{25}$$

$$u = 4.16 \text{ cm}$$

$$12 M = 1 + \frac{25}{f} = 1 + \frac{25}{5} = 6$$

$$13 u = 24 \text{ cm}$$

$$f = \frac{1}{2}r = 10 \text{ cm}$$

$$\frac{1}{v} = \frac{1}{10} - \frac{1}{24} = \frac{24-10}{240}$$

$$v = 17.1 \text{ cm (real)}$$

$$M = \frac{v}{u} = \frac{17.1}{24} = 0.71$$

$$0.71 = \frac{h_i}{h_o}$$

$$h_i = 0.71 \times 2 = 1.42 \text{ cm}$$

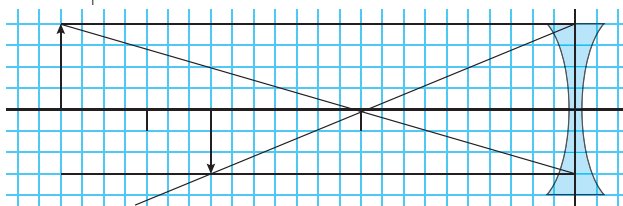

$$14 u = 5 \text{ cm}$$

$$f = \frac{1}{2}r = 10 \text{ cm}$$

$$\frac{1}{v} = \frac{1}{10} - \frac{1}{5} = \frac{5-10}{50}$$

$$v = -10 \text{ cm (virtual)}$$

$$M = \frac{v}{u} = \frac{10}{5} = 2$$

$$2 = \frac{h_i}{h_o}$$

$$h_i = 2 \times 2 = 4 \text{ cm}$$

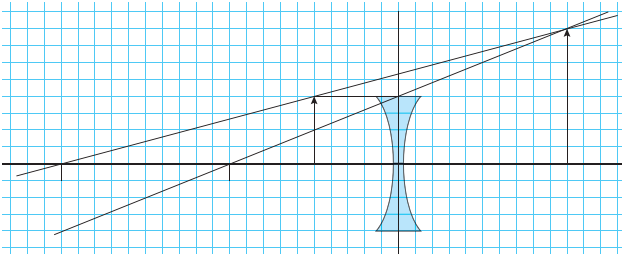

15 $v = 30 \text{ cm}$
 $u = 20 \text{ cm}$

$$\frac{1}{f} = \frac{1}{u} + \frac{1}{v} = \frac{1}{20} + \frac{1}{30} = \frac{3+2}{60}$$

$$f = 12 \text{ cm}$$

16 $u = 5 \text{ cm}$

$$f = \frac{1}{2}r = -10 \text{ cm}$$

$$\frac{1}{v} = \frac{1}{f} - \frac{1}{u} = \frac{1}{-10} - \frac{1}{5} = \frac{-1-2}{10}$$

$$v = -3.33 \text{ cm}$$

$$M = \frac{v}{u} = \frac{3.33}{5}$$

$$\frac{3.33}{5} = \frac{h_i}{h_o}$$

$$h_i = 3.33 \times \frac{2}{5} = 1.33 \text{ cm}$$

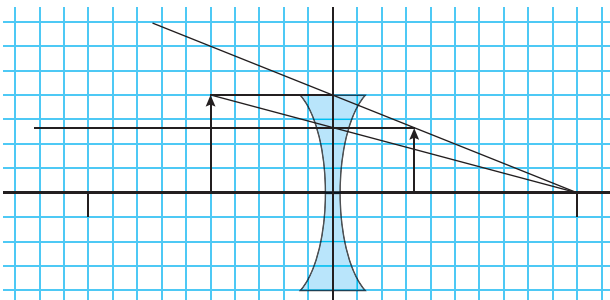

17 (a) For objective, $u = 1.5 \text{ cm}$, $f = 1 \text{ cm}$
 $\frac{1}{v} = \frac{1}{f} - \frac{1}{u} = \frac{1}{1} - \frac{1}{1.5} = \frac{3-2}{3} = \frac{1}{3} \Rightarrow v = 3 \text{ cm}$

(b) For eyepiece, $v = -25 \text{ cm}$, $f = 5 \text{ cm}$
 $\frac{1}{u} = \frac{1}{f} + \frac{1}{v} = \frac{5+1}{25} = \frac{6}{25}$ $u = 4.17 \text{ cm}$

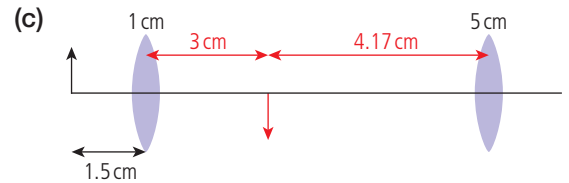

Can be seen from diagram that distance between lenses
 $= 3 + 4.17 \text{ cm} = 7.17 \text{ cm}$

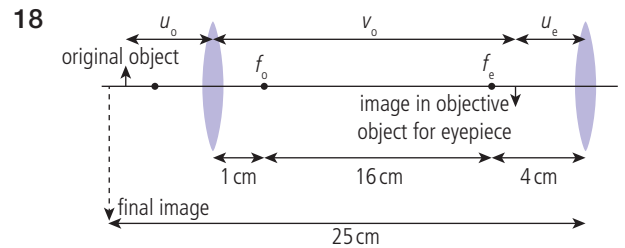

For the eyepiece:

$$f = 4 \text{ cm}$$

$$v_e = -25 \text{ cm (we know the image is virtual)}$$

$$\frac{1}{u} = \frac{1}{f} - \frac{1}{v} = \frac{1}{4} - \frac{1}{-25} = \frac{25+4}{100}$$

$$u_e = 3.45 \text{ cm}$$

For the objective:

$$v_o = 21 - 3.45 = 17.55 \text{ cm}$$

$$f = 1 \text{ cm}$$

$$\frac{1}{u} = \frac{1}{f} - \frac{1}{v} = \frac{1}{1} - \frac{1}{17.55} = \frac{17.55-1}{17.55}$$

$$u_o = 1.06 \text{ cm}$$

$$\text{Linear magnification of objective lens} = \frac{17.55}{1.06}$$

$$= 16.6$$

$$\text{Linear magnification of eyepiece lens} = \frac{25}{3.45}$$

$$= 7.2$$

$$\text{Overall angular magnification} = 16.6 \times 7.2$$

$$= 120$$

19 (a) $d = \frac{1.22 \lambda f_o}{D} = \frac{1.22 \times 600 \times 10^{-9} \times 2 \times 10^{-2}}{1 \times 10^{-2}}$
 $= 1.46 \times 10^{-6} \text{ m}$

(b) $\lambda_{\text{oil}} = \frac{\lambda_{\text{air}}}{n}$ so $d = \frac{1.46 \times 10^{-6}}{1.8} = 8.1 \times 10^{-7} \text{ m}$

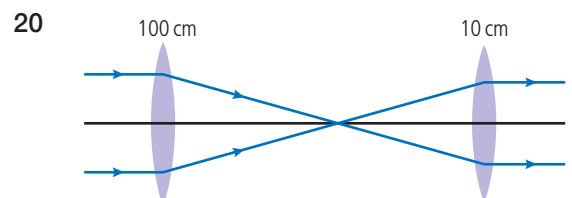

(a) Angular magnification $= \frac{f_o}{f_e} = \frac{100}{10} = 10$

(b) Distance between lenses $= f_o + f_e = 110 \text{ cm}$

(c) Eye ring is the image of objective in eyepiece

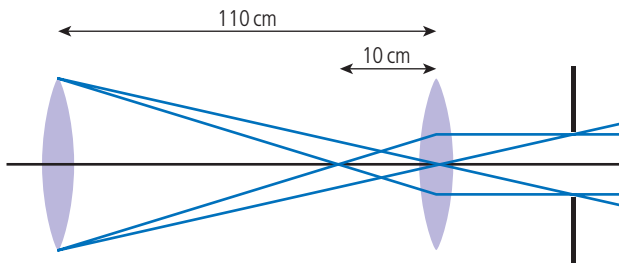

$$u = 110 \text{ cm}$$

$$f = 10 \text{ cm}$$

$$\frac{1}{v} = \frac{1}{f} - \frac{1}{u} = \frac{1}{10} - \frac{1}{110} = \frac{11-1}{110}$$

$$v = 11 \text{ cm from the eyepiece}$$

21



$$\text{Angular magnification} = \frac{f_o}{f_e}$$

$$10 = \frac{50}{f_e} \quad f_e = 5 \text{ cm}$$

22

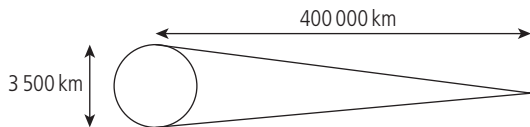

$$\theta = \frac{3.5}{400} = 8.75 \times 10^{-3} \text{ rad}$$

23

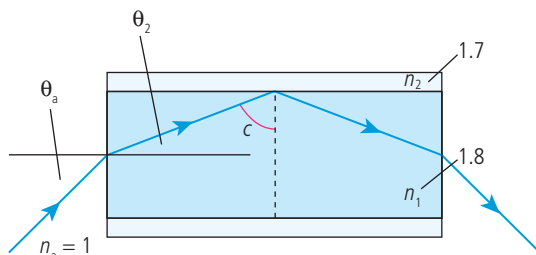

$$\sin c = \frac{n_2}{n_1}$$

$$c = \sin^{-1}\left(\frac{1.7}{1.8}\right) = \sin^{-1}(0.94) = 71^\circ$$

$$\theta_2 = 90^\circ - c = 19^\circ$$

Apply Snell's law to light entering fibre:

$$\frac{\sin \theta_a}{\sin \theta_2} = \frac{n_2}{n_1}$$

$$\sin \theta_a = \sin 19^\circ \times 1.8$$

$$\theta_a = 36^\circ$$

$$24 \quad P_{\text{in}} = 1 \text{ mW}$$

$$(a) \text{ Attenuation} = 10 \log_{10} \left(\frac{P_{\text{in}}}{P_{\text{out}}} \right)$$

$$P_{\text{out}} = 0.1 \text{ mW}; \quad A = 10 \log_{10}(10) = 10 \text{ dB}$$

$$(b) P_{\text{out}} = 0.2 \text{ mW}; \quad A = 10 \log_{10}(5) = 7 \text{ dB}$$

$$(c) P_{\text{out}} = 0.01 \text{ mW}; \quad A = 10 \log_{10}(100) = 20 \text{ dB}$$

$$25 \quad (a) \text{ After 5 km, attenuation} = 5 \times 2 = 10 \text{ dB}$$

$$(b) P_{\text{in}} = 1 \text{ mW}$$

$$\text{Attenuation} = 10 \text{ dB} = 10 \log_{10} \left(\frac{1}{P_{\text{out}}} \right)$$

$$\Rightarrow P_{\text{out}} = 0.1 \text{ mW}$$

$$26 \quad I_0 = 0.1 \text{ kW m}^{-2}$$

$$I = 0.8 \text{ kW m}^{-2}$$

$$x = 4 \text{ mm}$$

$$(a) I = I_0 e^{-\mu x}$$

$$\Rightarrow \log_e \left(\frac{I}{I_0} \right) = -\mu x$$

$$\mu = \frac{1}{x} \log_e \left(\frac{I_0}{I} \right)$$

$$= 5.6 \times 10^{-2}$$

$$(b) x_{1/2} = \frac{0.693}{\mu} = 12.4 \text{ mm}$$

$$27 \quad I_0 = 0.5 \text{ kW m}^{-2}$$

$$x = 3 \text{ mm}$$

$$(a) \mu = \frac{0.693}{x_{1/2}} = 0.693 \text{ mm}^{-1}$$

$$(b) I = I_0 e^{-\mu x} = 0.5 \times e^{-0.693 \times 3} = 0.0625 \text{ kW m}^{-2}$$

$$28 \quad (a) 40\% \text{ reduction} \Rightarrow \frac{I}{I_0} = \frac{40}{100} = e^{-\mu x}$$

$$x = 6 \text{ mm} \quad \Rightarrow 0.4 = e^{-\mu \times 6}$$

$$\log_e(0.4) = -\mu x$$

$$\mu = \frac{1}{x} \log_e(0.4)$$

$$= 0.153 \text{ mm}^{-1}$$

$$(b) x_{1/2} = \frac{0.693}{0.153} = 4.5 \text{ mm}$$

29 $\mu_b = \frac{0.693}{1.8} = 0.385 \text{ cm}^{-1}$
 $\mu_m = \frac{0.693}{3.5} = 0.198 \text{ cm}^{-1}$

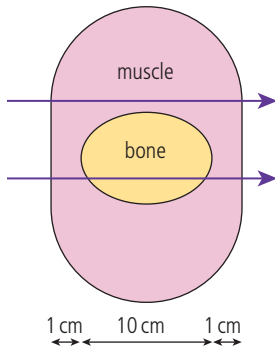

12 cm muscle:

$$\frac{I_0}{I_1} = e^{-\mu_m x_m} = e^{-0.198 \times 12} = 0.093$$

$\Rightarrow 9.3\%$

2 cm muscle and 10 cm bone:

$$\frac{I_0}{I_2} = e^{-(\mu_m x_m + \mu_b x_b)} = e^{-(0.198 \times 2 + 0.385 \times 10)} = 0.014$$

$\Rightarrow 1.4\%$

30 $Z = \rho c$; for muscle $Z = 1540 \times 1060$
 $= 1.63 \times 10^6 \text{ kg m}^{-2} \text{ s}^{-1}$

for bone $Z = 3780 \times 1900$
 $= 7.18 \times 10^6 \text{ kg m}^{-2} \text{ s}^{-1}$

for fat $Z = 1480 \times 900$
 $= 1.33 \times 10^6 \text{ kg m}^{-2} \text{ s}^{-1}$

31 Greatest percentage reflection from greatest difference in impedance, so bone and fat.

32 $\frac{I_r}{I_0} = \left(\frac{Z_2 - Z_1}{Z_2 + Z_1} \right)^2 = \left(\frac{7.18 - 1.63}{7.18 + 1.63} \right)^2$
 $= 0.397$
 $\Rightarrow 39.7\%$

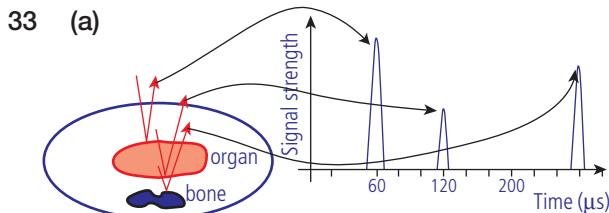

Depth of organ can be found from 1st peak
 Time for reflection = $60 \mu\text{s}$
 Distance travelled = $60 \times 10^{-6} \times 1500$
 $= 0.09 \text{ m} = 9 \text{ cm}$
 $\Rightarrow \text{Depth} = 4.5 \text{ cm}$

(b) Time for reflection from far side of organ
 $= 120 \mu\text{s}$

Distance travelled = $120 \times 10^{-6} \times 1500$
 $= 18 \text{ cm}$

$\Rightarrow \text{Depth} = 9 \text{ cm}$

Thickness of organ = $9 - 4.5 = 4.5 \text{ cm}$

Practice questions

1 (a) (i) The point at which rays that are parallel to the axis converge.

(ii)

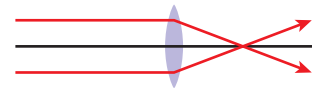
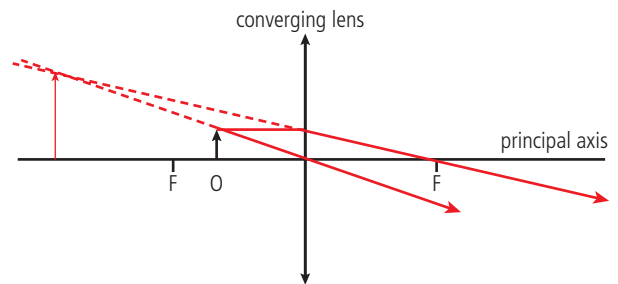

(iii) The image is virtual since rays don't really cross.

(b) $f = 6.25 \text{ cm}$
 $u = 5 \text{ cm}$

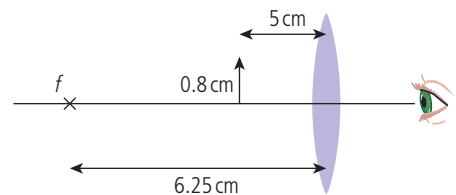

(i) Using $\frac{1}{u} + \frac{1}{v} = \frac{1}{f} \Rightarrow \frac{1}{5} + \frac{1}{v} = \frac{1}{6.25}$
 $\Rightarrow \frac{1}{v} = \frac{1}{6.25} - \frac{1}{5} = \frac{5 - 6.25}{5 \times 6.25} = \frac{-1.25}{31.25}$
 $\Rightarrow v = -25 \text{ cm}$

(ii) Linear magnification = $\frac{v}{u} = \frac{25}{5} = 5$
 So image is $5 \times \text{object} = 5 \times 0.8$
 $= 4.0 \text{ cm}$

- 2 (a) First draw the red ray that goes through the centre of the lens, appearing to come from the virtual image at I_2 . Then draw the dashed line parallel to the axis from the image at I_1 to the lens L_2 . Finally, draw the blue ray, which comes from the image at I_2 and passes through the point in the lens determined by the dashed line. This ray will cross the axis at the focal point.

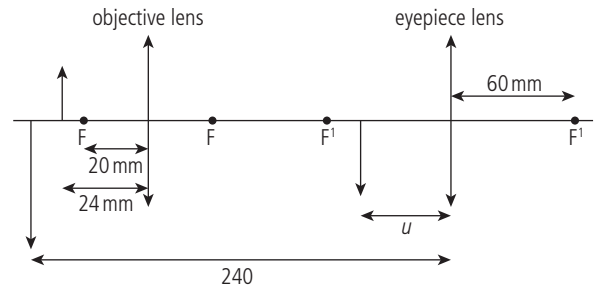
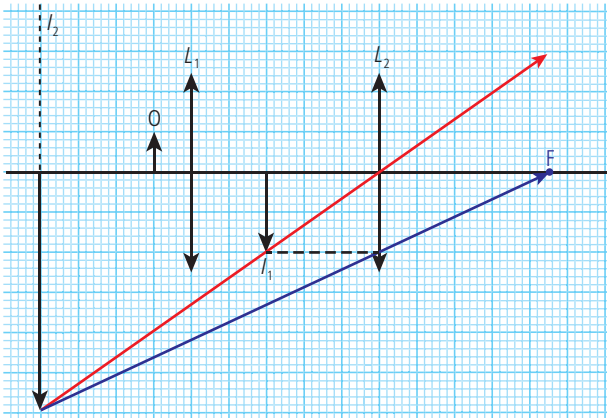

$$\text{Using } \frac{1}{f} = \frac{1}{u} + \frac{1}{v}$$

$$\Rightarrow \frac{1}{u} = \frac{1}{f} - \frac{1}{v}$$

$$\text{where } f = 60 \text{ mm}$$

$$v = -240 \text{ mm (negative since virtual)}$$

$$\frac{1}{u} = \frac{1}{60} - \frac{1}{-240} = \frac{(4+1)}{240}$$

$$u = \frac{240}{5} = 48 \text{ mm}$$

(b) Magnification in objective = $\frac{v}{u} = \frac{120}{24}$

Magnification in eyepiece = $\frac{v}{u} = \frac{240}{48}$

Total magnification = $\frac{120}{24} \times \frac{240}{48} = 25$

- 4 (a) Ultrasound frequency 1 MHz \rightarrow 20 MHz

You will just have to remember this. ☹

- (b) (i) Gel is applied to prevent the ultrasound from being reflected when it passes from air to body.

It does this by reducing the impedance difference.

Also makes the sensor slide more easily.

- (ii)

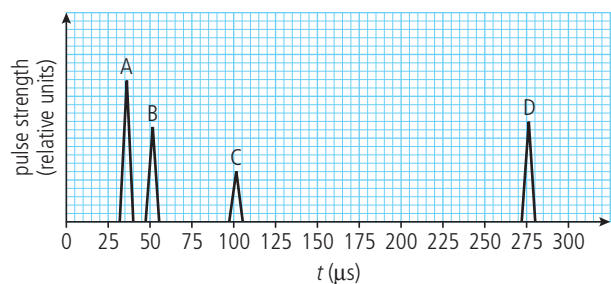
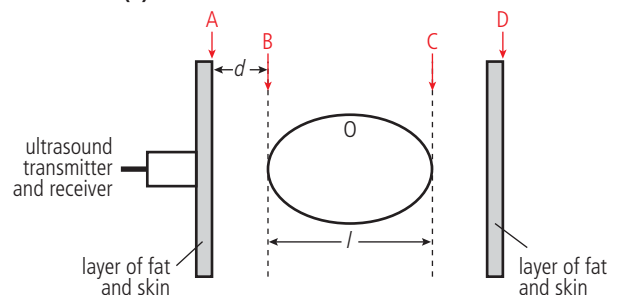

- (b) (i) Object is 1 cm tall and I_2 is 2 cm tall so linear magnification = 2

- (ii) Final image is 6 cm tall so linear magnification of eyepiece = $\frac{6}{2} = 3$

- (c) Total magnification = $2 \times 3 = 6$

- 3 (a) (i) Using the lens formula $\frac{1}{f} = \frac{1}{u} + \frac{1}{v}$

$$\Rightarrow \frac{1}{v} = \frac{1}{f} - \frac{1}{u}$$

$$\text{where } f = 20 \text{ mm}$$

$$u = 24 \text{ mm}$$

$$\frac{1}{v} = \frac{1}{20} - \frac{1}{24} = \frac{(24-20)}{480} = \frac{4}{480}$$

$$v = \frac{480}{4} = 120 \text{ mm}$$

- (ii) We know the image is real because the value for v is positive; this is because the object is further than the focal length from the convex lens.

- (iii) First put the image and object for the eyepiece onto the diagram (can't do this exactly but it helps to see their positions).

Each time there is a change in tissue, there is a reflection. The beam gets weaker as it passes through more tissue. When the beam passes out of the body the reflection is greater, since the change in impedance from tissue to air is large.

D should be passing from body to air not from organ to body.

(iii) $v = 1.5 \times 10^3 \text{ ms}^{-1}$

The depth of the organ can be found using peaks A and B.

Time for reflection = $50 - 35 = 15 \mu\text{s}$

\Rightarrow time to get to organ = $7.5 \mu\text{s}$

Depth of organ = $1.5 \times 10^3 \times 7.5 \times 10^{-6}$
 $= 1.1 \text{ cm}$

If B is one side of the organ and C the other, then time to pass from B to C to B is $50 \mu\text{s}$

Time from B to C = $\frac{50}{2} \mu\text{s} = 25 \mu\text{s}$

Thickness of organ

$$= 1.5 \times 10^3 \times 25 \times 10^{-6} = 3.8 \text{ cm}$$

(c) B-scan gives a 3D image.

(d) Advantage: non-ionizing

Disadvantages: small depth penetration, limit to size of objects that can be imaged, blurring of images

5 (a) (i) An X-ray picture shows up bones very clearly since X-rays are absorbed more by bone than soft tissue; this would therefore be the best choice to view a broken bone

(ii) It is too dangerous to use X rays to view a fetus so non-ionizing radiation such as ultrasound is used.

(b) (i) The half thickness is the thickness of the material required to reduce the intensity of an X-ray beam to half of its original intensity.

(ii) From graph $x_{1/2} = 4 \text{ mm}$

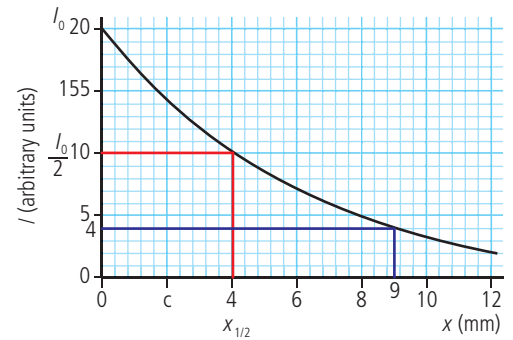

(iii) 20% of 20 = $0.2 \times 20 = 4$

from the graph the thickness required = 9 mm

(iv) Using $I = I_0 e^{-\mu x}$ where $\mu = \frac{\ln 2}{8}$
 $= 0.087 \text{ mm}^{-1}$

If 80% reduction then 20% gets through

$$\text{So } \frac{I}{I_0} = \frac{20}{100} = e^{-0.087x}$$

$$\Rightarrow \ln(0.2) = -0.087x \Rightarrow x = 18.5 \text{ mm}$$

6 (a) The half thickness is the thickness of material that will reduce the intensity of an X-ray beam by $\frac{1}{2}$.

(b) The half thickness for bone is $\frac{1}{150}$ \times the half thickness for soft tissue

$$t_{\frac{1}{2b}} = \frac{t_{\frac{1}{2s}}}{150}$$

$$\mu = \frac{\ln 2}{t_{\frac{1}{2}}}$$

$$\frac{\mu_b}{\mu_s} = \frac{\left(\frac{\ln 2}{t_{\frac{1}{2b}}}\right)}{\left(\frac{\ln 2}{t_{\frac{1}{2s}}}\right)} = \frac{t_{\frac{1}{2s}}}{t_{\frac{1}{2b}}} = 150$$

$$\mu_b = \mu_s \times 150 = 0.035 \times 150 = 5.3 \text{ cm}^{-1}$$

(c) (i) $I_B = I_A e^{-\mu_b x}$

$$\frac{I_B}{I_A} = e^{-0.035 \times 5} = 0.84$$

(ii) $I_C = I_B e^{-\mu_b x}$

$$\frac{I_C}{I_B} = e^{-5.3 \times 5} = 3.1 \times 10^{-12}$$

(d) Most of the X-rays pass through the soft tissue but almost all are absorbed by the bone; this means that a shadow of the bone will be cast on a photo plate placed under the leg.

- 7 (a) (i) Ultrasound is sound that is higher frequency than we can hear, over 20 kHz.
- (ii) Ultrasound is produced by applying an alternating voltage to a piezo-electric crystal. This causes molecules to align with the field, resulting in vibration.
- (b) $Z = \rho c = 2800 \times 1.5 \times 10^3$
 $= 4.2 \times 10^6 \text{ kg m}^{-2} \text{ s}^{-1}$
- (c) (i) The different parts of the brain are all made of the same material, so there is no difference in impedance, so no reflections.
- (ii) $\frac{I_R}{I_O} = \left(\frac{Z_1 - Z_2}{Z_1 + Z_2} \right)^2 = \left(\frac{1.6 \times 10^6 - 430}{1.6 \times 10^6 + 430} \right)^2 = 1$
- (iii) The previous answer shows that from air to tissue almost all of the ultrasound will be reflected. By placing gel between the transmitter and tissue the impedance difference is reduced, resulting in less reflection.
- (d) (i) The time between transmission and reflection = $50 \mu\text{s}$. This is the time to reach the stomach and back, so the time to the stomach = $25 \mu\text{s}$
Distance = $vt = 1600 \times 25 \times 10^{-6}$
 $= 4.0 \text{ cm}$
- (ii) An A scan simply shows the distance to the organ whereas a B scan gives an image.

Worked solutions

Chapter 12

Exercises

- 1 1 light year = 9.46×10^{15} m
 4×10^{13} km = 4×10^{16} m
 $\frac{4 \times 10^{16}}{9.46 \times 10^{15}} = 4.2$ light years
- 2 Distance from Sun to Earth = 1.5×10^{11} m
 $c = 3 \times 10^8$; $t = \frac{d}{c} = \frac{1.5 \times 10^{11}}{3 \times 10^8} = 500$ s
 = 8 min 20 s
- 3 Distance to nearest star = 4×10^{13} km
 $t = \frac{d}{v} = \frac{4 \times 10^{13}}{30000} = 1.3 \times 10^9$ hours
 = 1.5×10^5 years
- 4 1 pc = 3.26 light years = $3.26 \times 9.46 \times 10^{15}$ m
 Distance to nearest star
 = $4 \times 10^{13} \times \frac{10^3}{3.26} \times 9.46 \times 10^{15} = 1.3$ pc

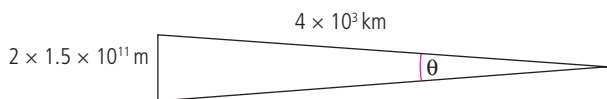

$$\theta = \frac{3 \times 10^{11}}{4 \times 10^{16}} = 7.5 \times 10^{-6} \text{ rad}$$

$$1 \text{ arcsec} = 4.8 \times 10^{-6} \text{ rad}$$

$$\theta = 1.56 \text{ arcsec}$$

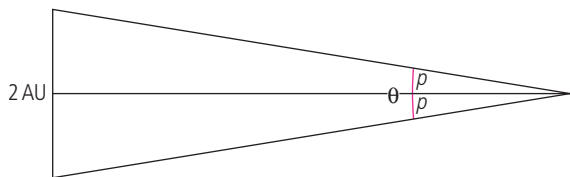

$$d = \frac{1}{\rho} = \frac{1}{0.78} = 1.28 \text{ pc}$$

5

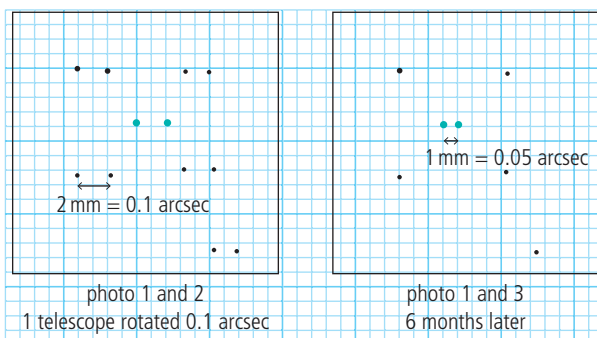

$$\text{parallax angle} = \frac{0.05}{2} = 0.025 \text{ arcsec}$$

$$d = \frac{1}{p} = 40 \text{ pc}$$

6

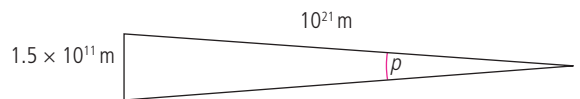

$$p = 1.5 \times \frac{10^{11}}{10^{21}} = 1.5 \times 10^{-10} \text{ rad}$$

$$1 \text{ arcsec} = 4.8 \times 10^{-6} \text{ rad}$$

$$p = 3.13 \times 10^{-5} \text{ arcsec}$$

$$(d = 3.2 \times 10^4 \text{ pc})$$

Photograph scale = 50 mm arcsec so

Angle between 6 months

$$= 2p = 6.26 \times 10^{-5} \text{ arcsec}$$

Distance on photograph = $50 \times 6.26 \times 10^{-5}$
 = 3.18×10^{-3} mm. This is too small to measure.

7



Estimate from size of spot on photograph:

Betelgeuse 1 (0.4)

Meissa 4 (3.5)

Bellatrix 2 (1.64)

Alnilam 3 (1.7)

Alnitak 3 (2)

Mintaka 3 (2.23)

Saiph 2 (2.09)

Rigel 0 (0)

actual values (from Wikipedia) in brackets

8 (a) $L = 3.839 \times 10^{26}$ W

$$d = 1.5 \times 10^{11} \text{ m}$$

$$b = \frac{L}{4\pi d^2} = 1.36 \times 10^3 \text{ Wm}^{-2}$$

(b) $d = 10 \text{ pc} = 10 \times 3.26 \text{ light years}$
 $= 32.6 \times 9.46 \times 10^{15} \text{ m} = 3.1 \times 10^{17} \text{ m}$

$$b = \frac{L}{4\pi d^2} = \frac{3.839 \times 10^{26}}{4\pi(3.1 \times 10^{17})^2}$$

$$= 3.2 \times 10^{-10} \text{ Wm}^{-2}$$

9 (a) $L = 25 L_{\odot} = 25 \times 3.839 \times 10^{26} \text{ W}$
 $= 9.6 \times 10^{27} \text{ W}$
 $d = 8.61 \text{ light years} = 8.61 \times 9.46 \times 10^{15} \text{ m}$
 $= 8.1 \times 10^{16} \text{ m}$

$$b = \frac{L}{4\pi d^2} = \frac{9.6 \times 10^{27}}{4\pi(8.1 \times 10^{16})^2}$$

$$= 1.2 \times 10^{-7} \text{ Wm}^{-2}$$

(b) Brightness at 10pc
 $(10 \times 3.26 \times 9.46 \times 10^{15} \text{ m} = 3.1 \times 10^{17} \text{ m})$
 $= \frac{9.6 \times 10^{27}}{4\pi(3.1 \times 10^{17})^2} = 7.9 \times 10^{-9} \text{ Wm}^{-2}$

10 $L = 5.0 \times 10^{31} \text{ W}$
 $b = 1.4 \times 10^{-9} \text{ Wm}^{-2}$
 $b = \frac{L}{4\pi d^2}$
 $d = \sqrt{\frac{L}{4\pi b}} = \sqrt{\frac{5.0 \times 10^{31}}{4\pi \times 1.4 \times 10^{-9}}} = 5.3 \times 10^{19} \text{ m}$

1 light year = $9.46 \times 10^{15} \text{ m}$
 $5.3 \times 10^{19} \text{ m} = \frac{5.3 \times 10^{19}}{9.46 \times 10^{15}}$
 $= 5.6 \times 10^3 \text{ light years}$

11 $r = 3.1 \times 10^{11} \text{ m}; \quad T = 2800 \text{ K}$
 $A = 4\pi r^2 = 1.2 \times 10^{24} \text{ m}^2$
 $L = \sigma A T^4 = 5.6 \times 10^{-8} \times 1.2 \times 10^{24} \times 2800^4$
 $= 4.2 \times 10^{30} \text{ W}$

12 (a) $\lambda_{\text{max}} = 400 \times 10^{-9} \text{ m}$
 $T = \frac{2.9 \times 10^{-3}}{400 \times 10^{-9}} = 7.25 \times 10^3 \text{ K}$

(b) $\text{Power/m}^2 = \sigma T^4 = 5.67 \times 10^{-8} \times 7250^4$
 $= 1.6 \times 10^8 \text{ Wm}^{-2}$

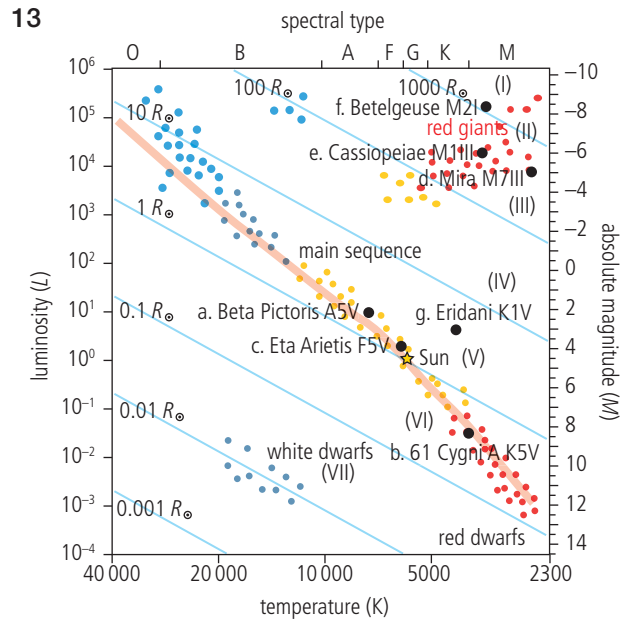

14 (a) $\lambda_{\text{max}} = 400 \times 10^{-9} \text{ m}$
 $\lambda_{\text{max}} = \frac{2.9 \times 10^{-3}}{T}$
 $T = \frac{2.9 \times 10^{-3}}{400 \times 10^{-9}} = 7250 \text{ K}$

(b) Difficult to find 7250 on scale since it is not linear but gives $\sim 1 L_{\odot}$

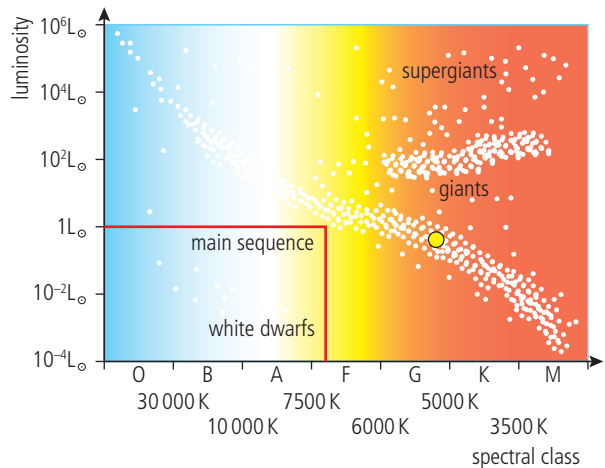

From HR diagram $L \sim L_{\odot}$
 $= 3.84 \times 10^{26} \text{ W}$

(c) $b = 0.5 \times 10^{-12} \text{ Wm}^{-2}$
 $b = \frac{L}{4\pi d^2}$
 $d = \sqrt{\frac{3.84 \times 10^{26}}{4\pi \times 0.5 \times 10^{-12}}}$
 $d = 7.8 \times 10^{18} \text{ m}$ or 826 light years

15 The spectral type of Beta Pictoris is A5V so from the HR diagram

(a) $L = 10L_{\odot}$

(b) $r = 2R_{\odot}$

(c) $T = 8000\text{K}$

(d) $d = \sqrt{\frac{L}{4\pi b}} = \sqrt{\frac{10L_{\odot}}{4\pi \times 6.5 \times 10^{-10}}} = 6.86 \times 10^{17}\text{m}$
 $= 22.2\text{pc}$

16 $\frac{L}{L_{\odot}} = \left(\frac{M}{M_{\odot}}\right)^{3.5} = 10$

$M = 10^{\frac{1}{3.5}} \times M_{\odot}$

$M = 1.9 M_{\odot}$

17 From figure, 20 days corresponds to a luminosity of $6 \times 10^3 L_{\odot}$.

$d = \sqrt{\frac{L}{4\pi b}} = \sqrt{\frac{6 \times 10^3 \times 3.84 \times 10^{26}}{4\pi \times 8 \times 10^{-10}}} = 1.5 \times 10^{19}\text{m}$
 $d = 490\text{pc}$

18 Mass of Beta Pictoris = $1.9M_{\odot}$

$\Delta t = (1.9)^{-2.5} \Delta t_{\odot} = 0.2 \Delta t_{\odot}$

19 $d = \sqrt{\frac{L}{4\pi b}} = \sqrt{\frac{10^{10}L_{\odot}}{4\pi \times 2.3 \times 10^{-16}}} = 3.6 \times 10^{25}\text{m}$
 $= 1200\text{Mpc}$

20

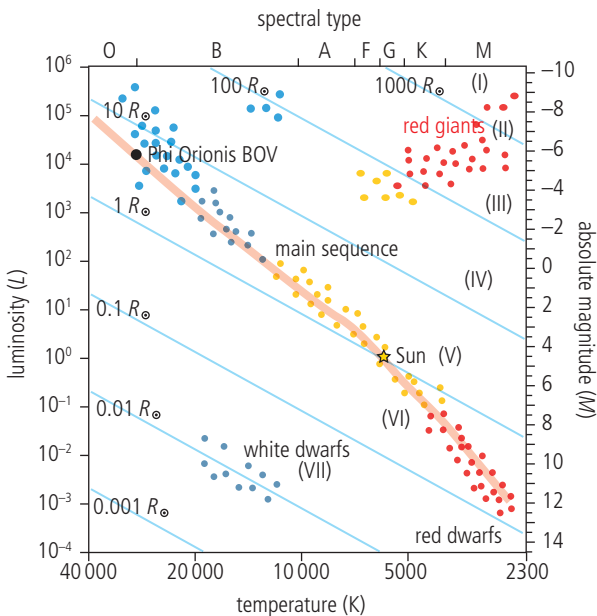

Luminosity of Phi Orionis is $\approx 2 \times 10^4 L_{\odot}$

$\frac{L}{L_{\odot}} = \left(\frac{M}{M_{\odot}}\right)^{3.5} = 2 \times 10^4$

$M = (2 \times 10^4)^{\frac{1}{3.5}} M_{\odot} = 17 M_{\odot}$

This is greater than the Oppenheimer–Volkoff limit ($3M_{\odot}$) so Phi Orionis could become a black hole

21 $\frac{\Delta\lambda}{\lambda} = \frac{v}{c}$

$\lambda = 434.0\text{nm}$

$\Delta\lambda = 479.8 - 434.0 = 45.8\text{nm}$

$v = c \times \frac{\Delta\lambda}{\lambda} = 3 \times 10^8 \times \frac{45.8}{434} = 3.17 \times 10^7\text{ms}^{-1}$

22 $\lambda = 434.0$; $\Delta\lambda = 481.0 - 434.0 = 47.0\text{nm}$

$v = c \times \frac{\Delta\lambda}{\lambda} = 3 \times 10^8 \times \frac{47}{434} = 3.25 \times 10^7\text{ms}^{-1}$

It is further away since it is moving faster.

23 $H_0 = \frac{\text{recessional velocity}}{\text{separation}}$

$\text{separation} = \frac{\text{recessional velocity}}{H_0} = \frac{150}{72} = 2.1\text{Mpc}$

24 $\text{recessional velocity} = H_0 \times \text{separation} = 72 \times 20 = 1440\text{km s}^{-1}$

25 $\rho_c = \frac{3H_0^2}{8\pi G}$ using H_0 in s^{-1}

$= 3 \times \frac{(2.33 \times 10^{-18})^2}{8\pi \times 6.7 \times 10^{-11}}$

$= 9.7 \times 10^{-27}\text{kg m}^{-3}$

Mass of one hydrogen atom = $1.7 \times 10^{-27}\text{kg}$

so this is equivalent to about 6 atoms per m^3 .

26 $\lambda_{\text{max}} = \frac{2.9 \times 10^{-3}}{2.73} = 1.06\text{mm}$

27 $\lambda_{\text{max}} = \frac{2.9 \times 10^{-3}}{3000} = 9.7 \times 10^{-7}\text{m}$

$z = \frac{\lambda_{\text{(obs)}} - \lambda_{\text{(em)}}}{\lambda_{\text{(em)}}} = \frac{1.06 \times 10^{-3} - 9.7 \times 10^{-7}}{9.7 \times 10^{-7}}$

$= 1.09 \times 10^3$

28 $\frac{R_{\text{(obs)}}}{R_{\text{(em)}}} = \frac{\lambda_{\text{(obs)}}}{\lambda_{\text{(em)}}} = \frac{1.06 \times 10^{-3}}{9.7 \times 10^{-7}} = 1093$

$R_{\text{(em)}} = \frac{1}{1093} = 9.2 \times 10^{-4}$

Practice questions

- 1 (a) (i) An alternative to temperature is spectral class.
(ii) An alternative to luminosity is absolute magnitude.

- (b) A = Main sequence
 B = Super red giant
 C = White dwarf
 D = Main sequence

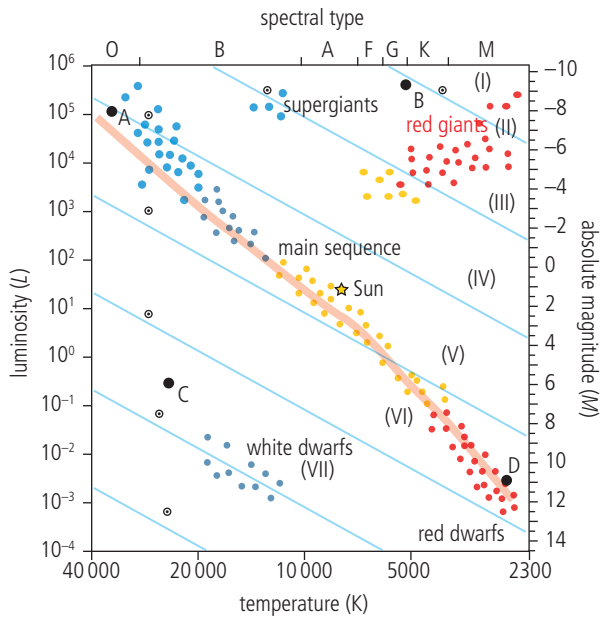

- (c) B is larger than A because even though B is colder it gives out more power (luminosity)
 $L = \sigma AT^4$ so if L is large and T is small, A must be big.

- (d) From HR diagram, $L_B = 10^6 L_\odot$
 $b_B = 7.0 \times 10^{-8} \text{ W m}^{-2}$
 $b_\odot = 1.4 \times 10^3 \text{ W m}^{-2}$
 $d_\odot = 1.0 \text{ AU}$
 $L = 4\pi b d^2 \Rightarrow L_B = 4\pi \times 7 \times 10^{-8} \times d^2$
 $L_\odot = 4\pi \times 1.4 \times 10^3 \times 1.0^2$
 So $\frac{L_B}{L_\odot} = \frac{4\pi \times 7 \times 10^{-8} \times d^2}{4\pi \times 1.4 \times 10^3 \times 1.0^2} = 10^6$
 $d = \sqrt{\frac{10^6 \times 1.4 \times 10^3}{7 \times 10^{-8}}} = 1.4 \times 10^8 \text{ AU}$
 $1 \text{ pc} = 2.1 \times 10^5 \text{ AU}$
 $d = \frac{1.4 \times 10^8}{2.1 \times 10^5}$
 $= 700 \text{ pc}$

- (e) At 700pc, the parallax angle will be too small to measure.
 $\theta \sim 7 \times 10^{-9} \text{ rad}$

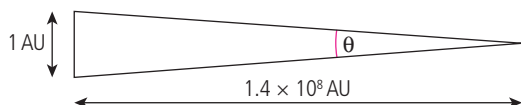

- 2 (a) The parallax angle, p is the angle subtended by a star to the Earth when the Earth has moved a distance of 1AU (1 Earth orbit radius). For practical reasons, the angle is usually measured when the Earth is either side of the Sun (times separated by 6 months); this gives an angle $2p$. This angle is measured by measuring the angle between the star and a very distant star, as shown in the diagram.

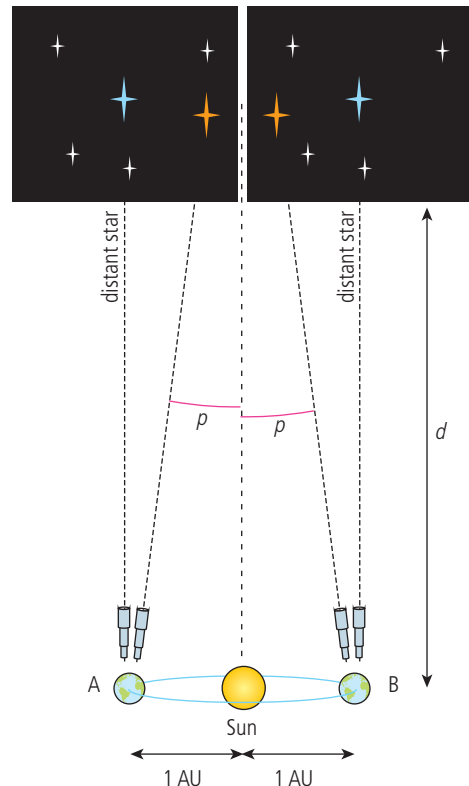

- (b) If parallax angle = 0.549 arc seconds then distance $d = 1/0.549 = 1.82 \text{ pc}$
 $= 1.82 \times 3.26 = 5.94 \text{ light years}$

- (c) (i) Apparent brightness is the radiant power received per unit area at the Earth.

(ii) $b = \frac{L}{4\pi d^2}$
 $\frac{b_b}{b_s} = \frac{(L_b/4\pi d_b^2)}{(L_s/4\pi d_s^2)}$
 $\frac{L_b}{L_s} = \frac{b_b d_b^2}{b_s d_s^2} = \frac{b_b}{b_s} \times \left(\frac{d_b}{d_s}\right)^2$
 $= 2.6 \times 10^{-14} \times (5.94 \times 6.3 \times 10^4)^2$
 $= 3.6 \times 10^{-3}$

- (d) Barnard's star is
- (i) not hot enough to be a white dwarf
 - (ii) too small to be a red giant (see position on HR diagram; Barnard's star is in fact a red dwarf)

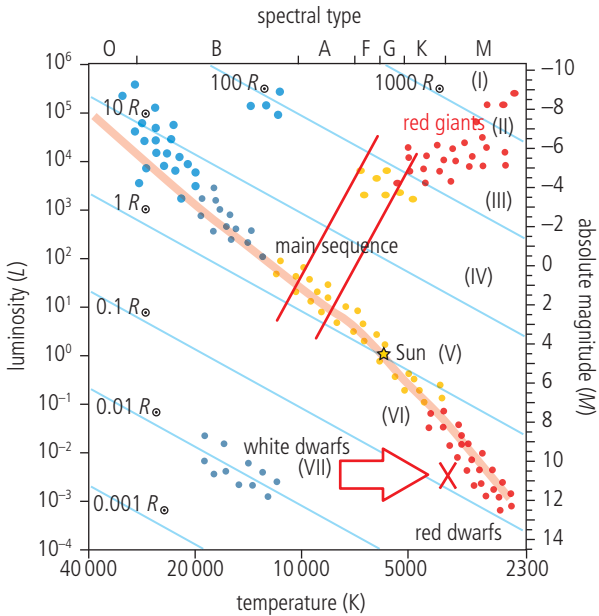

- 3 (a) (i) Luminosity is the total power radiated from a star.
- (ii) Apparent brightness is the power received from a star per m^2 by an observer on the Earth.

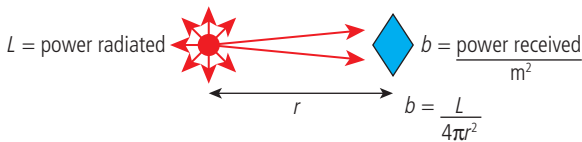

- (b) A Cepheid variable has a change in luminosity due to its change of size. When it expands, its surface area increases, so it radiates more energy, leading to increased luminosity and hence brightness.
- (c) (i) The brightness is greatest when the star is biggest. So it is biggest at 2 days.

- (ii) The period of a Cepheid is related to its luminosity, so if the period is measured its luminosity can be calculated. If the apparent brightness is measured, we can then find its distance from the Earth.
- In this way the distance to distant galaxies can be measured.

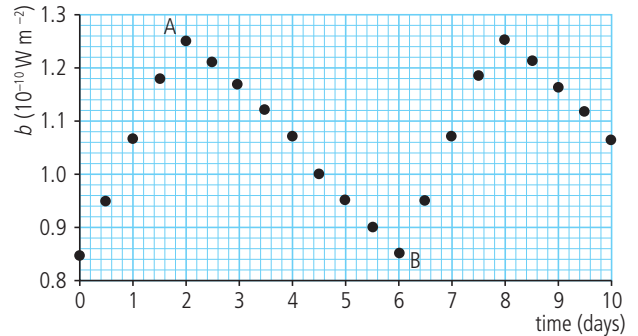

- (d) (i) $L = 7.2 \times 10^{29} \text{ W}$
and from the graph
 $b = 1.25 \times 10^{-10} \text{ W m}^{-2}$
 $b = \frac{L}{4\pi d^2} \Rightarrow d = \sqrt{\frac{L}{4\pi b}}$
 $d = \sqrt{\frac{7.2 \times 10^{29}}{4\pi \times 1.25 \times 10^{-10}}} = 2.14 \times 10^{19} \text{ m}$

- (ii) A standard candle is an object of known luminosity; it can be used to calculate distance by measuring its brightness. Since the luminosities of the Cepheid variables are known, they can be used as standard candles.

- 4 (a) We know that the Universe is expanding and that all particles of matter are attracted to each other by gravity. This means that the rate of expansion is getting less. The rate at which the expansion is slowing down depends on the density of the Universe. If very dense, it will stop expanding and start to collapse. If not very dense, it will keep on expanding forever. The critical density is the density beyond which the Universe will stop expanding.

(b) (i) $\rho_0 = \frac{3H_0^2}{8\pi G} = \frac{3 \times (2.7 \times 10^{-18})^2}{8\pi \times 6.7 \times 10^{-11}}$
 $= 1.3 \times 10^{-26} \text{ kg m}^{-3}$

- (ii) A nucleon has mass = 1.7×10^{-27} kg
 so number in $1 \text{ m}^3 = \frac{1.3 \times 10^{-26}}{1.7 \times 10^{-27}}$
 $= 7.7 \sim 8 \text{ per m}^3$

5 (a)

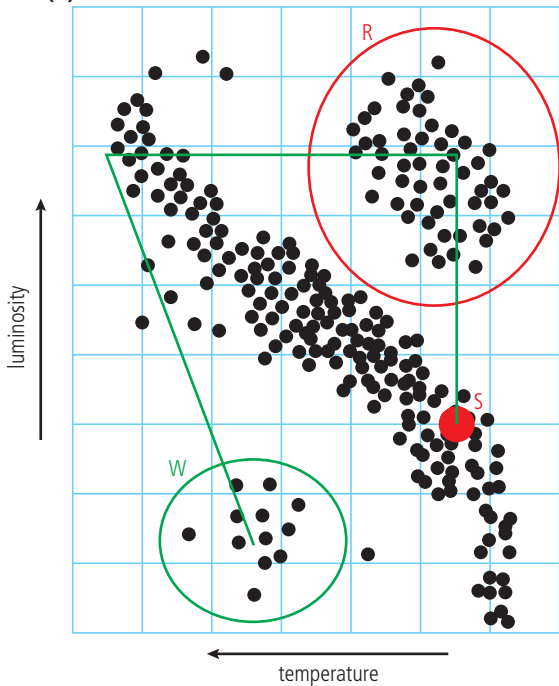

- (b) The amount of power radiated per m^2 depends on the temperature of the star.

$$\left(\frac{L}{A} = \sigma T^4\right)$$

So the total power emitted depends on the size and the temperature.

As a star grows, it has a bigger surface area so can give out more power even though it is cooler.

- 6 (a) The peak in the CMBR occurs at about 1.07 mm so using Wien's law we can calculate the temperature

$$T = \frac{2.9 \times 10^{-3}}{1.07 \times 10^{-3}} = 2.7 \text{ K}$$

- (b) This radiation is the same in all directions (on a large scale) and has the same spectrum as the radiation from a black body. This is the same type of radiation that would have filled the Universe soon after the Big Bang. At this time the wavelength would have been much shorter but it has expanded as the space it is in has expanded.
- (c) The fact that light from all distant galaxies is red-shifted implies that they are moving away from us. If space is expanding it must have been smaller in the past. This supports the idea that the Universe began with a Big Bang.